



## Installation and Operation Instructions for

# **MASCOT® ST**

Wall-Mounted, Modulating  
Gas Condensing Water Heater

Model MSTWW

199,000 BTU/hr

- Natural Gas (NG) - Factory Configuration
- Propane Gas (LP) - Field-Convertible



**FOR YOUR SAFETY:** This product must be installed and serviced by a professional service technician, qualified in hot water boiler and heater installation and maintenance. Improper installation and/or operation could create carbon monoxide gas in flue gases which could cause serious injury, property damage, or death. Improper installation and/or operation will void the warranty.

### **⚠ WARNING**

If the information in this manual is not followed exactly, a fire or explosion may result causing property damage, personal injury or loss of life.

Do not store or use gasoline or other flammable vapors and liquids in the vicinity of this or any other appliance.

#### **WHAT TO DO IF YOU SMELL GAS**

- Do not try to light any appliance.
- Do not touch any electrical switch; do not use any phone in your building.
- Immediately call your gas supplier from a nearby phone. Follow the gas supplier's instructions.
- If you cannot reach your gas supplier, call the fire department.

Installation and service must be performed by a qualified installer, service agency, or gas supplier.

### **⚠ AVERTISSEMENT**

Assurez-vous de bien suivre les instructions données dans cette notice pour réduire au minimum le risque d'incendie ou d'explosion ou pour éviter tout dommage matériel, toute blessure ou la mort.

Ne pas entreposer ni utiliser d'essence ou ni d'autres vapeurs ou liquides inflammables dans le à proximité de cet appareil ou de tout autre appareil.

#### **QUE FAIRE SI VOUS SENTEZ UNE ODEUR DE GAZ:**

- Ne pas tenter d'allumer d'appareils.
- Ne touchez à aucun interrupteur. Ne pas vous servir des téléphones dans le bâtiment où vous vous trouvez.
- Appelez immédiatement votre fournisseur de gaz depuis un voisin. Suivez les instructions du fournisseur.
- Si vous ne pouvez rejoindre le fournisseur de gaz, appelez le service des incendies.

L'installation et l'entretien doivent être assurés par un installateur ou un service d'entretien qualifié ou par le fournisseur de gaz.

**TABLE OF CONTENTS**

**SECTION 1**

**Product Accessories**

1.1 Introduction..... 1  
 1.1 Included with the Appliance..... 1

**SECTION 2**

**Product Characteristics**

2.1 Model Nomenclature..... 2  
 2.2 Specifications..... 3  
 2.3 Dimensions ..... 4  
 2.4 Names of Components ..... 5

**SECTION 3**

**Safety Regulations**

3.1 Safety Symbols ..... 6  
 3.2 Safety Precautions and Proper Use..... 8

**SECTION 4**

**Installation**

4.1 Location and Clearances ..... 10  
 4.2 Wall Mount Bracket ..... 11  
     4.2.1 Installation Height and Location ..... 11  
     4.2.2 Hang the Water Heater ..... 11  
 4.3 Combustion Air..... 12  
     4.3.1 Combustion Air from Room..... 12  
     4.3.2 Ducted Combustion Air ..... 12  
 4.4 Venting (exhaust)..... 14  
 4.5 General Location Guideline ..... 15  
 4.6 Locations for Vent Pipe Terminator ..... 15  
     4.6.1 Direct Venting Clearances ..... 16  
     4.6.2 Non-Direct Venting Clearances..... 17  
     4.6.3 Venting Requirements in Massachusetts..... 18  
 4.7 Air / Vent Connections at the Appliance..... 20  
     4.7.1 Vent / Air Pipe Lengths..... 20  
     4.7.2 Direct Venting..... 20  
     4.7.3 Indoor Combustion Air..... 21  
 4.8 Vent / Air Pipe Termination..... 21  
 4.9 Gas Supply and Piping ..... 23  
 4.10 Gas Supply Pressure ..... 26  
 4.11 Gas Set Up and Adjustment..... 26  
 4.12 Gas High Altitude Setting ..... 27  
 4.13 Natural Gas to Propane Conversion ..... 28  
 4.14 Plumbing Guideline..... 32  
 4.15 Disposal of Condensate..... 33  
 4.16 Pressure Relief Valve..... 34

4.17 Electrical Wiring Connections ..... 34  
 4.18 DIP Switches..... 35  
 4.19 Control Board, Electrical Diagram ..... 36  
 4.20 Ladder Diagram ..... 37  
 4.21 Electrical Connections ..... 38

**SECTION 5**

**Control Display and Operation**

5.1 Control Dial and Buttons ..... 40  
 5.2 LCD Overview ..... 41  
 5.3 Operating Mode ..... 42  
 5.5 Status Display Mode ..... 43  
 5.4 DHW Set Point Change Mode ..... 44  
 5.6 Installer Mode..... 45  
 5.7 Error Mode ..... 46

**SECTION 6**

**Error Codes**

6.1 Error Codes..... 47  
 6.2 Fault Tree Analysis..... 50

**SECTION 7**

**Trouble Shooting**

7.1 Diagnostics..... 52  
 7.1 Failure Modes ..... 53

**SECTION 8**

**Maintenance**

8.1 Annual Startup and General Maintenance ..... 56

**SECTION 9**

**Installation Check**

9.1 Quick View ..... 57  
 9.2 Final Check Lists..... 57

**SECTION 10**

**Repair Part Diagram**

10.1 Part List..... 62  
 10.2 Notes: ..... 66

**SECTION 1. Product Accessories**

**1.1 Introduction**







This manual provides information necessary for the installation, operation, and maintenance of the LAARS Heating Systems **Mascot ST**. All application and installation procedures must be read and reviewed completely before proceeding with the installation. Consult the LAARS Heating Systems factory, or your local factory representative, with any problems or questions regarding this equipment. Experience has shown that most operating problems are caused by improper installation.

All installations must be made in accordance with  
 1) American National Standard Z223.1/NFPA54-Latest Edition "National Fuel Gas Code" or

2) CSA B149.1 "Natural Gas and Propane Installation Code" and with the requirement of the local utility or other authorities having jurisdiction. Such applicable requirements take precedence over the general instructions contained herein.

All electrical wiring is to be done in accordance with the local codes, or in the absence of local codes, with: 1) The National Electrical Code ANSI/NFPA No. 70-latest Edition, or 2) CSA STD. C22.1 "Canadian Electrical Code - Part 1". This appliance must be electrically grounded in accordance with these codes.

**1.2 Included with the Appliance**

Items	Descriptions	Qty
LAARS Tankless Water Heater		1
Installation Instructions and User's Manual		1
Condensate Hose		1
Wall Mount Bracket		1
Bolts w/Anchors		4
Vent terminal cap 3"		2
Parts Kit		1

## SECTION 2.

### Product Characteristics

#### 2.1 Model Nomenclature

The Model Nomenclature is shown on your Rating Plate and consists of a series of letters and numbers

( **Nomenclature** ) that further identifies the characteristics of your Mascot ST.

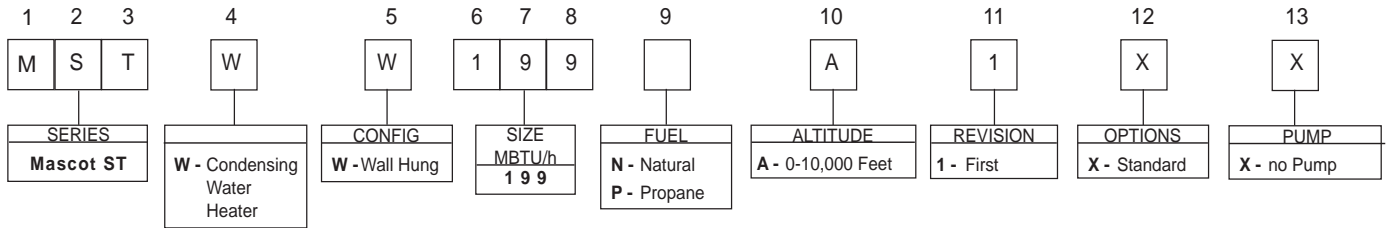

**Figure 1. Model Nomenclature**

**2.2 Specifications**

Model Name		MSTWW199	
Gas Input Rate	MAX	199,000 Btu/h	
	MIN	19,900 Btu/h	
Hot Water Capacity	35°F Rise	11.0 GPM	
	45°F Rise	8.5 GPM	
	77°F Rise	5.0 GPM	
Installation		Indoor Wall Hung	
Flue System		Sealed Combustion Direct & Single Vnet	
Vent Run		2"(50ft) / 3"(100ft) Schedule 40 PVC, CPVC, PP, ABS	
Gas Supply Pressure	NG	3.5" WC to 10.5" WC	
	LP	8.0" WC to 13.0" WC	
Manifold Pressure	Gas Type	NG	LP
	MAX Fire	-0.11" to -0.17" WC	-0.07" to -0.11" WC
	MIN Fire	-0.10" to -0.16" WC	-0.06" to -0.10" WC
Power Supply	Main Supply	120V 60Hz / 4A	
	Maximum Power Consumption	135W(82W+53W_Ceramic heater)	
Ignition System		Direct Electronic Ignition / Automatic Flame Sensing	
Burner System		Single Orifice Premixed Fuel Modulation Metal Fiber Infrared	
Gas Valve System		Air ratio valve	
Minimum Flow Rate		0.5 GPM	
Internal Pipe Material		STS 304	
Dimensions		W17.3 " – H28.7 " – D14.8 "	
Weight		88 lbs	
Sub Heat Exchanger Water Capacity		Under 2 Gallon	
Control Panel / Main Controller		P-920C / GTH-9500C	
Water Pressure	MAX	Hot water 150 psi	
	MIN	15 psi	
Connection Sizes	Cold Water Inlet / Hot Water Outlet	3/4"NPT	
	Gas Inlet	3/4"NPT	
Materials	Casing	Cold Rolled Carbon Steel	
	Heat Exchanger	Primary Heat Exchanger : STS 304 Secondary Heat Exchanger : STS 304	
Safety Devices		Flame Rod, Overheat Cut Off Limit Switch , Gas Leak Detector sensor, Exhaust Temperature High Limit Switch, Water Temperature High Limit Switch, Frost Protection Ceramic Heater	

- Temperature  
 Operating ambient Temperature Range : -10 to 60°C.  
 Operating Relative Humidity up to: 90% at 40°C.  
 Shipping & Storage Temperature Range of : -20 to 80°C.

2.3 Dimensions

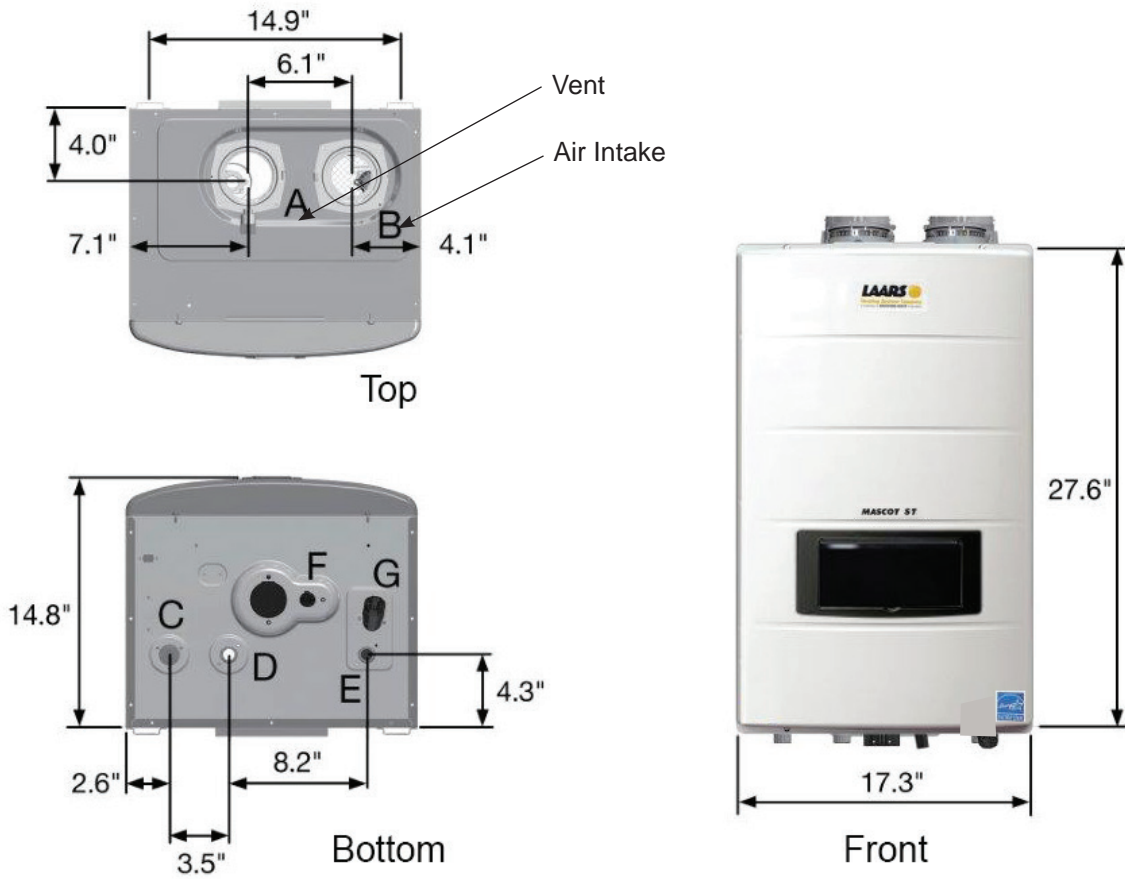

	Description	Diameter
A	Vent Pipe Collar	3"
B	Air Intake Collar	3"
C	Gas Inlet	3/4"
D	DHW Outlet	3/4"
E	DHW Inlet	3/4"
F	Condensate Drain	1/2"
G	Cold Water Inlet Filter	-

2.4 Names of Components

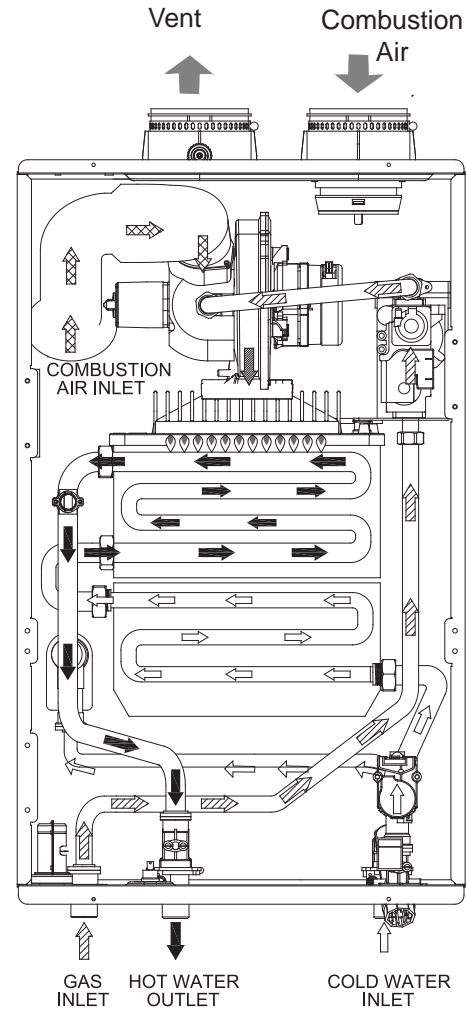
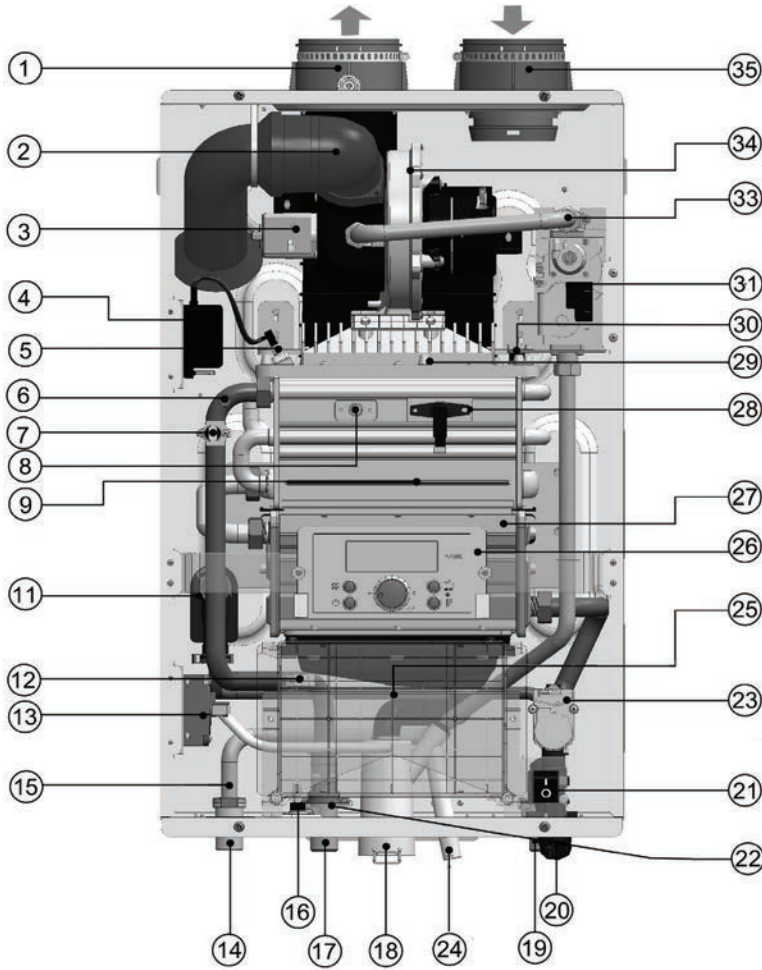

#	Name of Component
1	Vent Pipe Collar
2	Combustion Air Intake Assembly
3	Air Gas Mixture (AGM) Actuator
4	Ignition Transformer
5	Igniter
6	Operating Temperature Sensor
7	Switch High Limit
8	Sight Glass
9	Primary Heat Exchanger
11	Mixing Valve
12	Frost Protection
13	Air Pressure Switch
14	Gas Inlet
15	Gas Inlet Pipe
16	Freeze Protector Sensor
17	Domestic Hot Water (DHW) Outlet
18	Condensate Trap Cleanout

#	Name of Component
19	Cold Water Inlet
20	Cold Water Inlet Filter
21	Manual Power Switch
22	DHW Temperature Sensor
23	Water Adjustment Valve
24	Condensate Trap Hose
25	Main Controller
26	Control Panel
27	Secondary Heat Exchanger
28	Flame Detection Sensor
29	Burner Case
30	Burner Overheat Switch
31	Gas Valve
32	Venting (exhaust) Duct
33	Gas Manifold
34	Blower
35	Air Intake Collar



## SECTION 3.

### Safety Regulations

#### 3.1 Safety Symbols

##### WARNING

To avoid product damage, personal injury, or even possible death, carefully read, understand, and follow all the instructions in the Installation and Operation manual before installation, operation and service the Water Heater.

Laars cannot anticipate every circumstance that might involve a potential hazard. Therefore, all possible incidents are not included in our warnings. Proper installation, operation, and service are your responsibility.

You must make sure that the operation and settings of the Water Heater are safe for you and for others.

This manual provides Safety Symbols. When the user fails to adhere to the following requirement, it may cause death, serious injury, and substantial property damage.

For safety symbols, 'DANGER', 'WARNING', 'CAUTION' are indicated and the definitions for these terms are as follow:

##### DANGER

Indicates an imminently hazardous situation which, if not avoided, will result in death or serious injury. This signal word is limited to the most extreme situations.

##### WARNING

Indicates a potentially hazardous situation which, if not avoided, could result in death or serious injury.

##### CAUTION

Indicates a potentially hazardous situation which, if not avoided, may result in minor or moderate injury. It is also used to alert against unsafe practices and hazards involving only property damage.

##### WARNING

#### FOR YOUR SAFETY READ BEFORE OPERATING

If you do not follow these instructions exactly, a fire or explosion could result causing property damage, personal injury or loss of life.

A. This appliance does not have a pilot. It is equipped with an ignition device which automatically lights the burner. Do not try to light the burner by hand.

B. BEFORE OPERATING smell all around the appliance area for gas. Be sure to smell next to the floor because some gas is heavier than air and will settle on the floor.

#### WHAT TO DO IF YOU SMELL GAS

- Do not try to light any appliance.
- Do not touch any electric switch; do not use any phone in your building.
- Immediately call your gas supplier from a neighbor's phone. Follow the gas supplier's instructions.
- If you cannot reach your gas supplier, call the fire department.

C. Use only your hand to push in or turn the gas control knob. Never use tools. If the knob will not push in or turn by hand, don't try to repair it, call a qualified service technician. Force or attempted repair may result in a fire or explosion.

D. Do not use this appliance if any part has been under water. Immediately call a qualified service technician to inspect the appliance and to replace any part of the control system and any gas control which has been under water.

This appliance must be installed in accordance with local codes if any; if not, follow ANSI Z224.1/NFPA 54 or CAN/CSA B149.1, Natural Gas and Propane Installation Code, as applicable.

- This appliance is certified for use at altitudes up to 4,500ft(1,370m) in accordance to the latest CSA/CGA 2.17-M91 Gas-Fired Appliances for Use at High Altitudes.



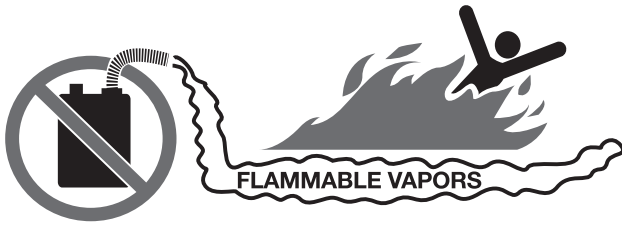

**⚠ DANGER**

- Vapors from flammable liquids will explode and catch on fire. These will cause death or severe burns.  
Do not use or store flammable products such as gasoline, solvents or adhesives in the same room or area near the appliance.

**Keep flammable products**

- Far away from water heater
- In approved containers
- Tightly closed
- Out of children’s reach

**Vapors**

- Cannot be seen
- are heavier than air
- spread on the floor
- Can spread from other rooms to the main burner by air currents

Do not install the appliance where flammable products will be stored.  
Read and follow water heater warnings and instructions thoroughly. If owner’s manual is missing, contact the retailer or manufacturer.

- The Laars Water Heater must be installed by a qualified plumber, a licensed gas fitter, and/or a professional service technician. Improper installation and/or operation will cause a potentially hazardous situation, such as serious injury or death. Also, it will void the warranty.
  - The National Fuel Gas Code NFPA 54 / ANSI Z224.1
  - National Electric Code ANSI/NEPA 70
  - All applicable local, state, national and provincial codes, regulations and laws.
- Proper care is your responsibility. Carefully read and understand the Operating Information in this manual before operating the Laars Water Heater.
- Be aware of the location of the gas shut-off valve and operation method. Close the gas shut-off valve immediately if the appliance is subjected to fire, overheating, flood, physical damage, or any other

damaging condition that might affect the operation of the unit. Water Heater must be checked by a qualified technician before resuming operation.

- DO NOT use this Water Heater if any part has been under water. Immediately call a qualified technician for inspecting the Water Heater and replacing any part of the control system and gas control which have been under water.
- Do not power up the unit until the gas and water supply valves are fully opened. Make sure that the fresh air intake port and exhaust gas port are opened and functional.
- DO NOT attempt to install, repair, or service this Water Heater by yourself. Do not change any part of the Water heater. Contact a qualified technician if the Water Heater needs repair or maintenance. Ask your gas supplier for a list of qualified service providers.
- DO NOT use spray paint, hair spray, or any other flammable spray near Water Heater or near the exterior fresh air inlet port. DO NOT place any items in or around the exterior exhaust gas outlet port and/ or fresh air inlet port. These could restrict or block the flow in or out of the vent system.
- “Caution: While repairing control, all wires are labeled. You must connect the wires in accordance with the instruction. Wiring errors can cause improper and dangerous operation.
- “Verify proper operation after servicing operation”
- This consists of the gas ignition system components which are protected from water (dripping, spraying, rain, etc.) during operation and service (circulator replacement, condensate trap, control replacement, etc.).
- After installing the heater, safety device must be tested.
- This water heater is equipped with a blocked vent shutoff system. If the error code ‘41’ occurs, follow the instructions below.
  - First, turn off the manual gas valve.
  - Make sure that there is no foreign object in the vent passage or rodent screen.
  - If you do not find any problem, do the following.
  - Turn off the error state by pressing the power button of control panel.
  - If the error occurs repeatedly, call your service technician or gas supplier.

## SECTION 3. Safety Regulations

### 3.2 Safety Precautions and Proper Use

#### Before Operation

##### 1. Check the Gas Type (NG/LP)

When using or moving the unit for the first time, check if gas type matches with the gas type of the Water Heater. Check whether the gas type which is supplied is NG (Natural Gas) or LP (Propane) and also check the Water Heater gas type.

The gas type is indicated on the rating plate on side of the Water Heater.

##### 2. Check the Power (120V 60Hz)

Check that the appliance is connected properly.

##### 3. Check the Cold Water

Inlet valve. Please keep the appliance water inlet valve open at all times. The appliance will not ignite when insufficient water or no water is in the heating pipes.

##### 4. Check the Gas Valve

Check that the manual gas shut-off valve that supplies the Mascot ST is opened.

5. Check the area around the appliance and remove any combustible or flammable materials. Remove laundry or any other items that are on or near the water heater or exhaust vent.

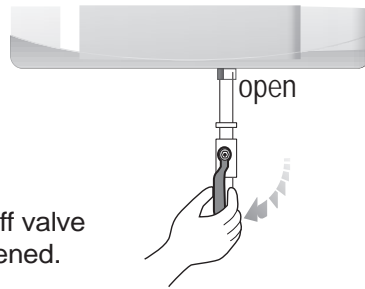

#### When in Operation CAUTION

##### 1. Caution for Gas leak

Frequently check for a gas leak at the gas connection portion with soapy water.

##### 2. Caution for Ventilation

Make sure that there is sufficient inflow and outflow of air ventilation while using the unit.

If the ventilation is improper, combustion quality may deteriorate inside the appliance and cause shortened life of the appliance.

##### 3. Burn Warning

Be careful not to burn yourself on the flue or pipes. They become extremely hot during operation.

**! WARNING**

Do not use the appliance for any other purpose than for heating and hot water.

Do not store combustibles or flammable material such as gasoline near the appliance.

Do not store other items on or near this water heater.

Do not store combustible (flammable) materials such as papers.

Do not hang clothes on the exhaust stack. This may start a fire.

**Burn Protection**

Be cautious when opening the hot water tap. The water is very hot. Especially, children or the elderly whose skin is liable to burn must not use the hot water without help of a guardian.



- After repair of gas pipeline or gas regulator replacement, call a qualified contractor for inspection before starting it up.

**Carbon monoxide poisoning**

If exhaust fumes enter the room, it could cause poisoning by carbon monoxide gas. Check that the exhaust tubes are properly connected. Open windows for ventilation. Call a qualified service technician for immediate repair.

Steps to take if you have a Gas leak.

1. Shut down the water heater as soon as gas fumes are detected.
2. Close the intermediate gas valve.
3. Open windows for ventilation.
4. Call a qualified service technician for immediate repair.

**Gas leakage test.**

Gas supply line must be inspected regularly.

Do not shut off the Water Heater.

When you leave home for a long time, do not shut off Water Heater. The Water Heater has a freeze protection function. The ceramic heater is installed inside of the heater's internal pipe to protect the heater from freezing.

Do not wipe the appliance or control panel with wet cloth. Electric shock may occur, or internal parts may fail due to the exposure to moisture.

Do not disassemble the Water Heater.

If repair is required, call your local qualified technician.

## SECTION 4. Installation

### 4.1 Location and Clearances

The Mascot ST must be mounted to a suitable wall by a qualified heating contractor under the guidelines of a wall mounted water heater.

The wall may be of concrete or wood. Suitable fasteners for concrete or wood must be used. Failure to wall mount this water heater using correct fasteners will affect the performance and life expectancy of the water heater and will void the warranty.

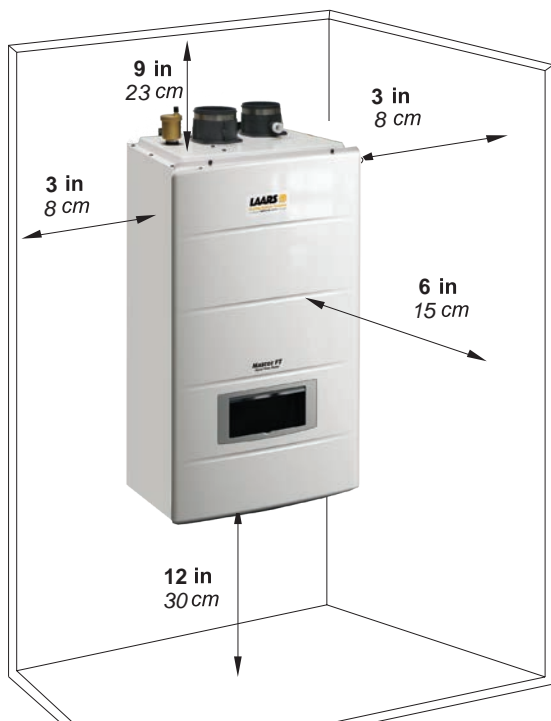

**Figure 2. Locating the Appliance**  
Minimum clearances to Combustibles.

For installation from Non-Combustibles and Combustibles		Suggested Service Clearance
TOP of appliance	9 in (23 cm)	18 in (46 cm)
BACK of appliance	5/8 in (1.5 cm)	5/8 in (1.5 cm)
FRONT of appliance	6 in (15 cm)	40 in (101 cm)
SIDE of appliance	3 in (7 cm)	8 in (20 cm)
BOTTOM of appliance	12 in (30 cm)	24 in (61 cm)

**Table 1. Minimum Clearances to Combustibles and for Service.**

### **!** WARNING

- Installations must comply with
  - All the local, state, provincial, and national codes, laws, regulations and ordinances.
  - National Fuel Gas Code, ANSI Z224.1 – The latest version.
  - National Electrical Code.
  - A National Standard of Canada CAN/CSA-B149.1-05
- Check before placing the Water Heater
  - Always check the connected components which are near to the heater. The components are below.
- Water piping position / Venting adapter / Gas supply piping / Electrical power / Condensate drain hose.
  - Confirm area around Water Heater. Remove any combustible materials, gasoline and other flammable liquids. Failure to keep Water Heater area clear and free of combustible materials, gasoline and other flammable liquids and vapors can result in severe personal injury, death or substantial property damage.
  - The Water Heater which has gas control system components must be protected from any possible danger during operation and service.
  - If new Water Heater replaces the existing appliance, check and correct system problems, for example:
    - Do not install : System leaks causing oxygen corrosion or heat exchanger cracks from hard water deposits.
- Provide clearances as outlined in Table 1
  - As for vent connector and hot water pipe from combustible construction, please consult with a qualified technician.
  - If the heater was installed in a narrow space or corner, please ensure that there is sufficient space for service and maintenance access. For regular maintenance, there should not be any problem to approach gas and water line.
- The water heater must be installed on a wall that can bear its weight.

### **!** WARNING

- CLEARANCES FOR SERVICE ACCESS
  - The water heater must be installed on a wall that can bear its weight.
  - Adequate service clearance must be considered.
  - The Water heater can be installed on any suitable internal wall (sound proofing may be required when installing onto a stud partition wall).

## 4.2 Wall Mount Bracket

- 4.2.1 The installation height and location** for your Mascot ST depends on your installation scenario. With all clearances considered, and given adequate positioning for air supply and venting, you will need to determine the best position to mount the Wall Mount Bracket. The wall must be concrete, wood, or plywood over studs, and must be strong enough to hold the water heater!
- Start by familiarizing yourself to how the included Wall Mount Bracket hooks underneath the two Hangers that are attached to the back of the water heater. The 'hooks' of the Wall Mount Bracket will be 3" from the Top of the water heater once the water heater is hung.
- Position the Wall Mount Bracket at the location that it will go, being sure that it is level, and then drill 4 holes (0.47" dia) with a 1/2" drill bit, into the wall through the Bracket.
- If mounting to a concrete wall, then use the concrete anchors. If onto wood or 5/8" (16 mm) plywood, then use the wood screws. Do not hang the Mascot ST onto sheetrock unless it is possible to fasten directly into the structural studs. If the included anchors do not suit your installation, you must use 'Field Supplied' anchors that are appropriate for the wall's construction.

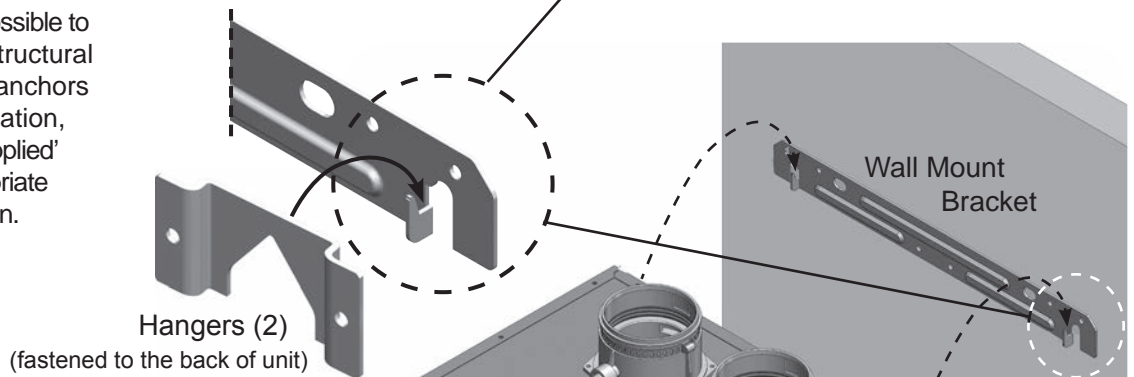
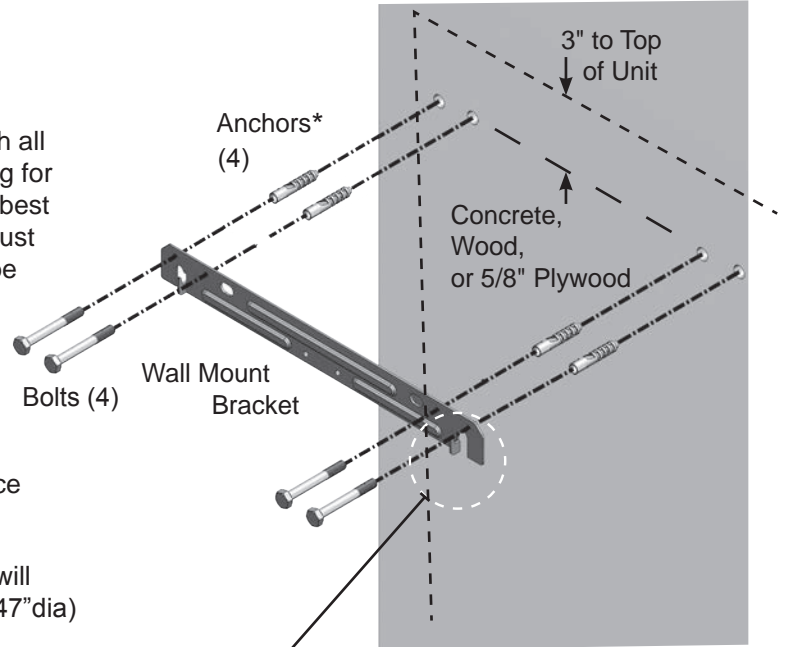

### 4.2.2 Hang the Water Heater

- Lift the water heater up, align the Hangers on the back of the water heater with the hooks on the Wall Mount Bracket, and hang the water heater onto the Wall Mount Bracket. Do a visual inspection to make sure that the water heater is hanging properly onto the hooks of the Wall Mount Bracket.
- Fasten the bottom of the water heater to the wall using 2 suitable wall anchors (field supplied).



## SECTION 4. Installation (continued)

### 4.3 Combustion Air

Mascot ST water heaters must have provisions for combustion and ventilation air in accordance with the applicable requirements for Combustion Air Supply and Ventilation in the National Fuel Gas Code, ANSI Z223.1; or in Canada, the Natural Gas and Propane Installation Code, CSA B149.1. All applicable provisions of local building codes must also be adhered to.

**A Mascot ST unit can take combustion air from the space in which it is installed, or the combustion air can be ducted directly to the unit. Ventilation air must be provided in either case.**

#### 4.3.1 Combustion Air from Room

In the United States, the most common requirements specify that the space shall communicate with the outdoors in accordance with method 1 or 2, which follow. Where ducts are used, they shall be of the same cross-sectional area as the free area of the openings to which they connect.

**Method 1:** Two permanent openings, one commencing within 12" (300mm) of the top and one commencing within 12" (300mm) of the bottom, of the enclosure shall be provided. The openings shall communicate directly, or by ducts, with the outdoors or spaces that freely communicate with the outdoors. When directly communicating with the outdoors, or when communicating to the outdoors through vertical ducts, each opening shall have a minimum free area of 1 square inch per 4000 Btu/hr (550 square mm/kW) of total input rating of all equipment in the enclosure. When communicating to the outdoors through horizontal ducts, each opening shall have a minimum free area of not less than 1 square inch per 2000 Btu/hr (1100 square mm/kW) of total input rating of all equipment in the enclosure.

**Method 2:** One permanent opening, commencing within 12" (300mm) of the top of the enclosure, shall be permitted. The opening shall directly communicate with the outdoors or shall communicate through a vertical or horizontal duct to the outdoors or spaces that directly communicate with the outdoors and shall have a minimum free area of 1 square inch per 3000 Btu/hr (734 square mm/kW) of the total input rating of all equipment located in the enclosure. This opening must not be less than the sum of the areas of all vent connectors in the confined space.

Other methods of introducing combustion and ventilation air are acceptable, providing they conform to the requirements in the applicable codes listed above.

In Canada, consult local building and safety codes or, in absence of such requirements, follow CAN/CGA B149.

#### 4.3.2 Ducted Combustion Air

The combustion air can be taken through the wall, or through the roof. When taken from the wall, it must be taken from out-of-doors by means of the LAARS horizontal wall terminal. When taken from the roof, a field-supplied rain cap or an elbow arrangement must be used to prevent entry of rain water.

Use ABS, PVC, CPVC, polypropylene, or galvanized pipe for the combustion air intake. Route the intake to the water heater as directly as possible. Seal all joints. Provide adequate hangers. The unit must not support the weight of the combustion air intake pipe. Maximum linear pipe length allowed is shown in [Table 6](#). Subtract 5 allowable linear ft. (1.5m) for every elbow used.

The connection for the intake air pipe is at the top of the unit.

In addition to air needed for combustion, air shall also be supplied for ventilation, including air required for comfort and proper working conditions for personnel.

### COMBUSTION AIR INSTALLATION STANDARDS

MATERIAL	UNITED STATES	CANADA
ABS	ANSI/ASTM D1527	Air pipe material must be chosen CPVC, sch 40, ANSI/ASTM, Polypropylene based upon the intended application of the water heater.
PVC, sch 40	ANSI/ASTM D1785 or D2665	
CPVC, sch 40	ANSI/ASTM F441	
Polypropylene	UL1738, ULC S636.	
Single wall galv. steel	26 gauge	

**Table 2. Required Combustion Air Pipe Material.**



**⚠ NOTICE**

The instructions for the installation of the venting system shall specify that the horizontal portions of the venting system shall be supported to prevent sagging; the methods of and intervals for support shall be specified. These instructions shall also specify that the venting system:

Category I, II and IV water heaters must be installed so that horizontal sections have a slope of at least ¼ inch per foot (21 mm/m) to prevent accumulation of condensate; and

For Category II and IV water heaters, where necessary, have means provided for drainage of condensate.

**⚠ AVIS**

Les instructions d'installation du système d'évacuation doivent préciser que les sections horizontales doivent être supportées pour prévenir le fléchissement. Les méthodes et les intervalles de support doivent être spécifiés. Les instructions doivent aussi indiquer les renseignements suivants:

les chaudières de catégories I, II et IV doivent présenter des tronçons horizontaux dont la pente montante est d'au moins ¼ po par pied (21 mm/m) entre la chaudière et l'évent; les chaudières de catégories II et IV doivent être installées de façon à empêcher l'accumulation de condensat;

et si nécessaire, les chaudières de catégories II et IV doivent être pourvues de dispositifs d'évacuation du condensat.

**⚠ CAUTION**

■ The Mascot ST is standard as a Natural Gas Water Heater and must be converted if propane is the desired gas, unless specifically manufactured for propane.

■ Adequate drainage

- The appliance should be installed not to damage the adjacent area. If such locations cannot be avoided, it is recommended that a suitable drain pan, adequately drained, be installed under the appliance. The pan must not block combustion air flow.

■ Connecting the Water Supply

- To conserve water and energy, insulate all water piping—especially the hot and recirculation water lines. Never cover the drain or pressure relief valve. Having a backflow preventer in the cold water supply line means that it prevent from thermal expansion backflow. Contact the water supplier or local plumbing inspector for information about how to control this situation. If overheating occurs or the gas supply fails to shut off, turn off the manual gas valve.

■ This installation must conform with below section

- “Air for Combustion and Ventilation” of the National Fuel Gas Code, ANSI Z224.1/NFPA 54, or Sections 8.2, 8.3 or 8.4 of Natural Gas and Propane Installation Code, CAN/CSA B149.1, or applicable provisions of the local building codes.



#### 4.4 Venting (Exhaust)

##### NOTICE

**DO NOT COMMON VENT MASCOT ST UNITS.**  
Mascot ST units are never permitted to share a vent with Category I appliances.

The flue temperature of the Mascot ST changes dramatically with changes in operating water temperature. Therefore, it is necessary to assess the application of the water heater to determine the required certified vent class. If the Mascot ST is installed in an application where the ambient temperature is elevated, and/or installed in a closet/alcove, CPVC, polypropylene, or stainless steel material is required. If the system temperatures are unknown at the time of installation, stainless, polypropylene or CPVC material is recommended.

The Mascot ST is a Category IV appliance and may be installed with PVC, CPVC or polypropylene that complies with ULC-S636, ANSI/ASTM D1785 F441 (see [Table 3](#)) or a stainless steel venting system that complies with UL 1738 Standard.

##### WARNING

Use of cellular core PVC (ASTM F891), cellular core CPVC, or Radel® (polyphenolsulfone) in venting systems shall be prohibited.

##### WARNING

Failure to use the appropriate vent material, installation techniques, glues/sealants could lead to vent failure causing property damage, personal injury or death.

##### WARNING

All venting must be installed according to this manual and any other applicable local codes, including but not limited to, ANSI Z224.1/NFPA 54, CSA B149.1, CSAB149.2 and ULC-S636. Failure to follow this manual and applicable codes may lead to property damage, severe injury, or death.

##### AVIS

**NE PAS ÉVENT COMMUNE MASCOTTE ST UNITÉS.**  
Mascotte ST unités ne sont jamais autorisés à partager un évent Catégorie I avec les appareils.

INSTALLATIONS IN CANADA require the use of venting material certified to ULCS636. All Gas vents connected to the Mascot ST, plastic, stainless steel or otherwise must be certified to this ULC standard. Appropriate selection of vent material is very important for proper performance and safe operation of the Mascot ST.

The flue temperature of the Mascot ST changes dramatically with changes in operating water temperature. Therefore, it is necessary to assess the application of the water heater to determine the required certified vent class. If the Mascot ST is installed in an application where the outlet water temperature exceeds 145°F, and/or installed in a closet, class IIB or higher vent material is required. If the system temperatures are unknown at the time of installation, class IIB or higher venting material is recommended.

IN CANADA all venting used must meet the following requirements:

1. ULC-S636 certified and marked
2. The first 3 feet of venting must be accessible for visual inspection.
3. All components used in the vent system must be from a certified manufacturer.
4. Vent system components must not be mixed with alternate manufacturers certified components and/or unlisted components.
5. The venting must be installed according to the vent manufacturers installation instructions.

The unit's vent can terminate through the roof, or

#### VENTING INSTALLATION STANDARDS

MATERIAL	UNITED STATES	CANADA
Stainless Steel	UL 1738	Venting must be ULC-S636 certified for use as venting material. The venting material must be chosen based upon the intended application of the water heater.
PVC, sch 40	ANSI/ASTM D1785	
CPVC, sch 40	ANSI/ASTM F441	
Polypropylene	UL1738 or ULC-S636	

**Table 3. Required Exhaust Vent Material.**

through an outside wall.

Vent pipe must pitch upward, toward the vent terminal, not less than 1/4" per foot, so that condensate will run back to the Mascot ST to drain. Route vent pipe to the heater as directly as possible. Seal all joints and provide adequate hangers as required in the venting system manufacturer's Installation Instructions. Horizontal portions of the venting system must be supported to prevent sagging and may not have any low sections that could trap condensate. The unit must not support the weight of the vent pipe.

### WARNING

- Failure to vent this Water Heater in accordance with these instructions could cause a fire, resulting in severe property damage, personal injury or death.
- Do not interchange vent systems or materials unless it is specified.
- The use of thermal insulation covering pipe and fittings is prohibited.
- Do not apply an electric damper, draft hood or vent damper with this Water Heater.
- Do not locate vent termination where exposed to prevailing winds. Moisture and ice may fall on surface around vent termination. To prevent deterioration, surface must be in good repair (sealed, painted, etc.).

## 4.5 General Location Guideline

1. Vent system installation must be in accordance with Local codes or, in the absence of local codes, the National Fuel Gas Code, ANSI Z224.1 /NFPA 54 and/or CSA B149.1, Natural Gas and Propane Installation Code.
2. The Water Heater is designed to be installed as a Direct Vent (sealed combustion) type. The air for combustion must be supplied directly from the outside to the burner. Also, the flue gases must be vented directly to the outdoors (through wall or roof).
  - Vent terminals must be at least 1 foot from any door, window, or gravity inlet into the building.
  - Maintain the correct clearance and orientation between the vent and air intake terminals. The vent and air intake terminals must be at the same height and their center lines must be spaced apart 12" minimum.
  - The bottom of the vent and air intake terminal must be at least 12" above the normal snow line. In no case should they be less than 12" above grade level.
3. Do not install venting system components on the exterior of building except as specifically required by these instructions
  - Do not install the vent terminal directly over windows or doors.
  - Air intake terminal must not terminate in areas that might contain combustion air contaminants, such as near swimming pools.
  - For sidewall venting, the minimum horizontal distance between any adjacent individual Module (Water Heater) vent terminations is twelve (12) inches. It is better to be far more than 12 inches for avoiding frost damage to building surfaces where vent terminations are placed.
  - The minimum horizontal distance between any adjacent individual module (water heater) roof vent endpiece is one (1) foot.

## 4.6 Locations for Vent Pipe Terminator

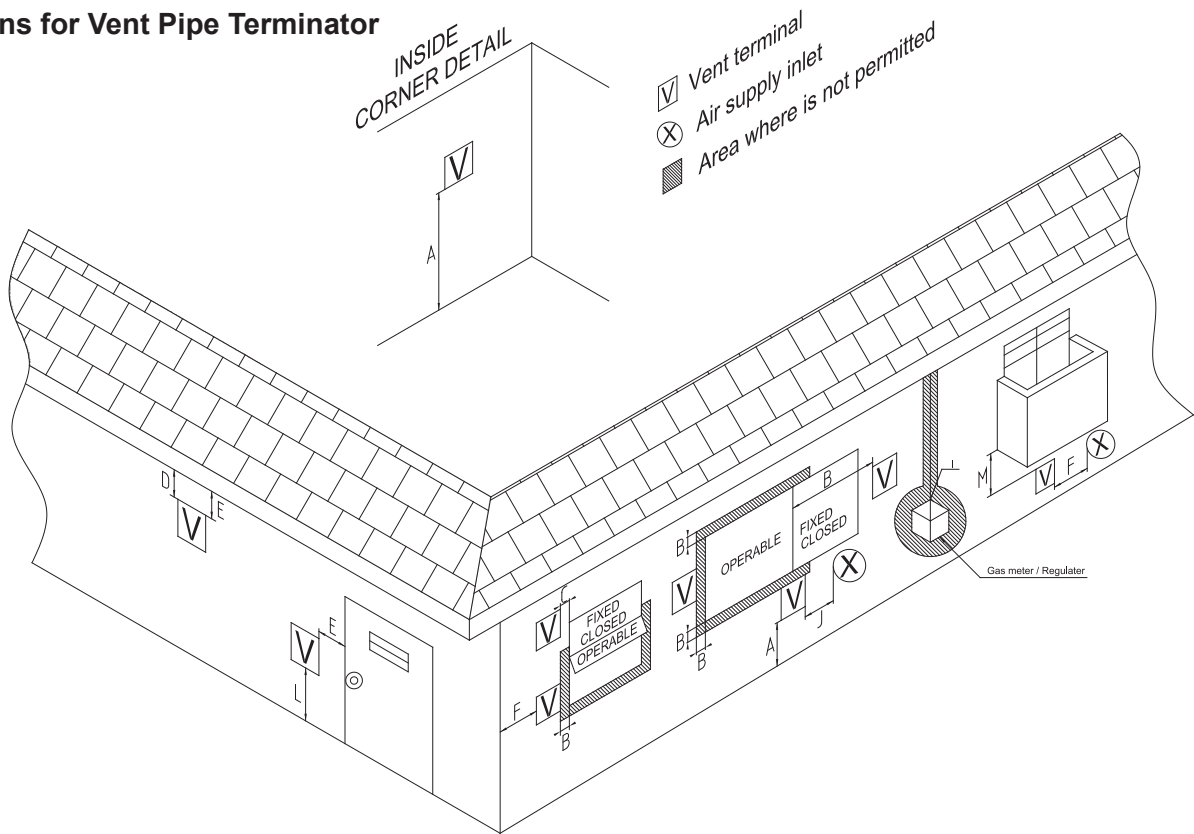

\* For clearances not specified in ANSI Z224.1 / NFPA 54 or CAN/CSA-B 149.1, please use clearances in accordance with local installation codes and the requirement of the gas supplier.

### 4.6.1 Direct Venting Clearances

	Description	US Direct Vent Installations	Canadian Direct Vent Installations
A	Clearance above grade, veranda, porch, deck, or balcony	12 in (30 cm)	12 in (30 cm)
B	Clearance to window or door that may be opening	12 in (30 cm)	36 in (91 cm)
C	Clearance to permanently closed window	*	*
D	Vertical clearance to ventilated soffit located above the terminal within a horizontal distance of 2 feet from the center line of the terminal	*	*
E	Clearance to unventilated soffit	*	*
F	Clearance to outside corner	*	*
G	Clearance to inside corner	*	*
H	Clearance to each side of center line extended above meter/regulator assembly	*	3 ft (91 cm) within a height 15 ft above the meter/regulator assembly
I	Clearance to service regulator vent outlet	*	3 ft (91 cm)
J	Clearance to non-mechanical air supply inlet to building or the combustion air inlet to any other appliance	12 in (30 cm)	36 in (91 cm)
K	Clearance to a mechanical air supply inlet	3 ft (91 cm) above if within 10 ft (3 m) horizontally	6 ft (1.83 m)
L	Clearance above paved sidewalk or paved driveway located on public property	*	7 ft (2.13 m)
M	Clearance under veranda, porch, deck, or balcony	*	12 in (30 cm)

Table 4. Direct Vent Clearances

**4.6.2 Non-Direct Venting (Single Pipe) Clearances**

	Description	US Non-Direct	Canadian Non-Direct
A	Clearance above grade, veranda, porch, deck, or balcony	12 in (30 cm)	12 in (30 cm)
B	Clearance to window or door that may be opening	48 in (120 cm) below or to side of opening; 12 in (30 cm) above opening	36 in (91 cm)
C	Clearance to permanently closed window	*	*
D	Vertical clearance to ventilated soffit located above the terminal within a horizontal distance of 2 feet from the center line of the terminal	*	*
E	Clearance to unventilated soffit	*	*
F	Clearance to outside corner	*	*
G	Clearance to inside corner	*	*
H	Clearance to each side of center line extended above meter / regulator assembly	*	36 in (91 cm) within a height 15 ft (4.57 m) above the meter/ regulator assembly
I	Clearance to service regulator vent outlet	*	36 in (91 cm)
J	Clearance to non-mechanical air supply inlet to building or the combustion air inlet to any other appliance	48 in (120 cm) below or to side of opening; 12 in (30 cm) above opening	36 in (91 cm)
K	Clearance to a mechanical air supply inlet	36 in (91 cm) above if within 10 ft (3 m) horizontally	6 ft (1.83 m)
L	Clearance above paved sidewalk or paved driveway located on public property	*	7 ft (2.13 m)
M	Clearance under veranda, porch, deck, or balcony	*	12 in (30 cm)

**Table 5. Non-Direct Vent Clearances**

### 4.6.3 Venting Requirements in the Commonwealth of Massachusetts

In Massachusetts the following items are required if the side-wall exhaust vent termination is less than seven (7) feet above finished grade in the area of the venting, including but not limited to decks and porches. From Massachusetts Rules and regulations 248 CMR 5.08

#### 1. Installation of Carbon Monoxide Detectors

At the time of installation of the side wall vented gas fueled appliance, the installing plumber or gasfitter shall observe that a hard-wired carbon monoxide detector with an alarm battery back-up is installed on the floor level where the gas appliance is to be installed. In addition, the installing plumber or gasfitter shall observe that a battery operated or hard-wired carbon monoxide detector with an alarm is installed on each additional level of the dwelling, building or structure served by the side-wall horizontally vented gas fueled equipment. It shall be the responsibility of the property owner to secure the services of qualified licensed professionals for installation of hard-wired carbon monoxide detectors.

a. In the event that the side-wall horizontally vented gas fueled equipment is installed in a crawl space or an attic, the hard-wired carbon monoxide with alarm and battery back-up may be installed on the next adjacent floor level.

b. In the event that the requirements of the subdivision cannot be met at the time of completion of installation, the owner shall have a period of thirty (30) days to comply with the above requirements, provided, however, that during said thirty (30) day period, a battery operated carbon monoxide detector with an alarm be installed.

#### 2. Approved Carbon Monoxide Detectors

Each carbon monoxide detector shall comply with NFPA 720 and be ANSI/UL 2034 listed and IAS certified.

3. Signage. A metal or plastic identification plate shall be permanently mounted to the exterior of the building at a minimum height of eight (8) feet above grade directly in line with the exhaust vent terminal for horizontally vented gas fueled heating appliance or equipment. The sign shall read, in print no less than one-half (1/2) inch in size: "GAS VENT DIRECTLY BELOW, KEEP CLEAR OF ALL OBSTRUCTIONS".

4. Inspection The state or local gas inspector of the side-wall horizontally vented gas fueled appliance shall not approve the installation unless, upon inspection, the inspector observes carbon monoxide detectors and signage installed in accordance with the provisions of 248 CMR 5.08(2)(a) 1-4.

**⚠ NOTICE**

**DO NOT COMMON VENT MASCOT ST UNITS.**  
Mascot ST units are never permitted to share a vent with Category I appliances.

**⚠ AVIS**

**NE PAS ÉVENT COMMUNE MASCOTTE ST UNITÉS.**  
Mascotte ST unités ne sont jamais autorisés à partager un évent Catégorie I avec les appareils.

**Common Vent Test**

NOTE: This section does not describe a method for common venting Mascot ST units. It describes what must be done when an existing unit is **removed** from a common vent system.

**⚠ NOTICE**

At the time of removal of an existing water heater, the following steps shall be followed with each appliance remaining connected to the common venting system placed in operation, while the other appliances remaining connected to the common venting system are not in operation.

1. Seal any Not Used openings in the common venting system.
2. Visually inspect the venting system for proper size and horizontal pitch and determine there is no blockage or restriction, leakage, corrosion and other deficiencies which could cause an unsafe condition.
3. Insofar as is practical, close all building doors and windows and all doors between the space in which the appliances remaining connected to the common venting system are located and other spaces of the building. Turn on clothes dryers and any appliance not connected to the common venting system. Turn on any exhaust fans, such as range hoods and bathroom exhausts, so they will operate at maximum speed.
4. Place in operation the appliance being inspected. Follow the lighting instructions. Adjust thermostat so the appliance will operate continuously.
5. Operate the main burner for 5 minutes then, determine if the cut-draw overflows to the discharge opening. Use the flame of a match or a candle or the smoke of a cigarette, a cigar or a pipe
6. Once it has been determined, according to the method indicated above, that each device connected to the drainage system is placed in the open air in an adequate manner. Install the doors and windows, fans, the registers of chimneys and gas appliances to their original position
7. Any malfunction of the venting system should be corrected so that the installation conforms to the National Fuel Gas Code, ANSI Z223.1/NFPA 54 and (or) the installation codes CAN/CSA-B149.1. If the size of a section of the evacuation system must be changed, the system should be modified to comply with the minimum values of the relevant tables of appendix F of the National Fuel Gas Code, ANSI Z223.1/NFPA 54 and (or) the installation codes CAN/CSA-B149.1

**⚠ AVIS**

Au moment du retrait d'une chaudière existante, les mesures suivantes doivent être prises pour chaque appareil toujours raccordé au système d'évacuation commun et qui fonctionne alors que d'autres appareils toujours raccordés au système d'évacuation ne fonctionnent pas:

1. Sceller toutes les ouvertures non utilisées du système d'évacuation.
2. Inspecter de façon visuelle le système d'évacuation pour déterminer la grosseur et l'inclinaison horizontale qui conviennent et s'assurer que le système est exempt d'obstruction, d'étranglement, de fuite, de corrosion et autres défaillances qui pourraient présenter des risques.
3. Dans la mesure du possible, fermer toutes les portes et les fenêtres du bâtiment et toutes les portes entre l'espace où les appareils toujours raccordés au système d'évacuation sont installés et les autres espaces du bâtiment. Mettre en marche les sècheuses, tous les appareils non raccordés au système d'évacuation commun et tous les ventilateurs d'extraction comme les hottes de cuisinière et les ventilateurs des salles de bain. S'assurer que ces ventilateurs fonctionnent à la vitesse maximale. Ne pas faire fonctionner les ventilateurs d'été. Fermer les registres des cheminées.
4. Mettre l'appareil inspecté en marche. Suivre les instructions d'allumage. Régler le thermostat de façon que l'appareil fonctionne de façon continue.
5. Faire fonctionner le brûleur principal pendant 5 min ensuite, déterminer si le coupe-tirage déborde à l'ouverture de décharge. Utiliser la flamme d'une allumette ou d'une chandelle ou la fumée d'une cigarette, d'un cigare ou d'une pipe.
6. Une fois qu'il a été déterminé, selon la méthode indiquée ci-dessus, que chaque appareil raccordé au système d'évacuation est mis à l'air libre de façon adéquate. Remettre les portes et les fenêtres, les ventilateurs, les registres de cheminées et les appareils au gaz à leur position originale.
7. Tout mauvais fonctionnement du système d'évacuation commun devrait être corrigé de façon que l'installation soit conforme au National Fuel Gas Code, ANSI Z223.1/NFPA 54 et (ou) aux codes d'installation CAN/CSA-B149.1. Si la grosseur d'une section du système d'évacuation doit être modifiée, le système devrait être modifié pour respecter les valeurs minimales des tableaux pertinents de l'appendice F du National Fuel Gas Code, ANSI Z223.1/NFPA 54 et (ou) les codes d'installation CAN/CSA-B149.1



## 4.7 Air Supply and Vent Connections at the Appliance

### 4.7.1 Vent / Air Pipe Lengths

Water Heater model	3" Combustion Air / Vent Pipe		2" Combustion Air / Vent Pipe	
	Max	Elbow Max	Max	Elbow Max
MSTWW199	100' (30M)	6	50' (15M)	4

**Table 6. Maximum Vent / Air Pipe Lengths for either 3" or 2" Pipes**

Note : For additional elbows, reduce maximum allowable length

- 5 feet (1.5M) for each additional 3-inch 90-degree elbow
- 2.5 feet (0.75M) for each additional 3-inch 45-degree elbow
- 5 feet (1.5M) for each additional 2-inch 90-degree elbow
- 4 feet (1.2M) for each additional 2-inch 45-degree elbow
- The thickness of the wall vents installed : Min 4" ~ Max 20"

### 4.7.2 Direct Venting

The water heater uses 3" or 2" diameter exhaust and 3" or 2" diameter intake air ducts. To ensure the draw of air directly from and exhaust of air directly to the outside of the building, create an airtight seal from the water heater collar to the vent termination.

**(For installations in Canada)** field-supplied plastic vent piping must comply with CAN/CGA B149.1 (latest edition) and be certified by the Standard For Type BH Gas Venting Systems, ULC-S636. Components of this listed system must not be interchanged with other vent systems or unlisted pipes or fittings. All plastic components and specified primers and glues of the certified vent system must be from a single system manufacturer and must not be intermixed with another system manufacturer's parts.

This water heater has a built-in control to limit the exhaust temperature.

#### ■ Tightening — Water Heater Collar (Socket) to Vent Pipe & Inlet Pipe

Canada has adopted standard ULC S636 which requires the following additional items.

The following steps for cement application are highlighted:

#### ■ Clean and dry your selected PVC, CPVC vent pipe and Laars Water Heater collar (socket).

- You can select to the size of vent pipe (2" & 3"), according to the installation conditions.
- Push the pipe into the collar (socket) until it touches the bottom of the socket fitting.

#### 3" pipe

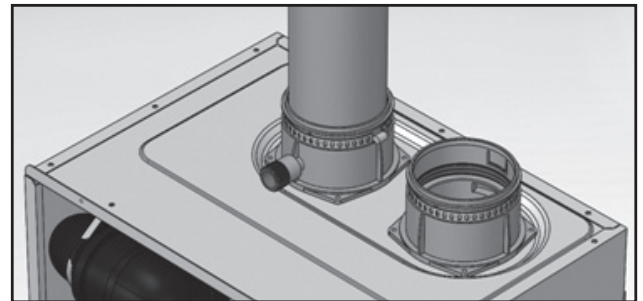

#### 2" pipe connected, using an adapter

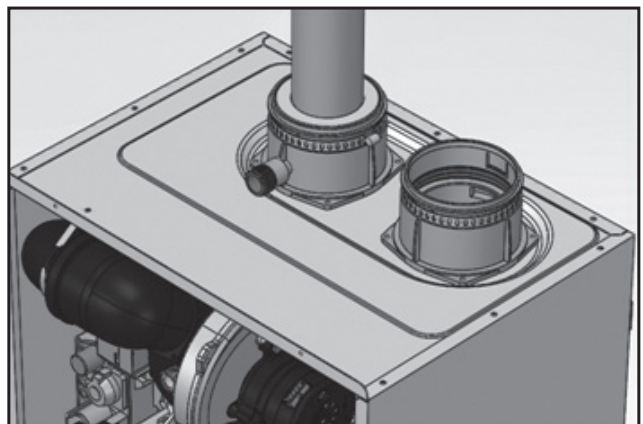
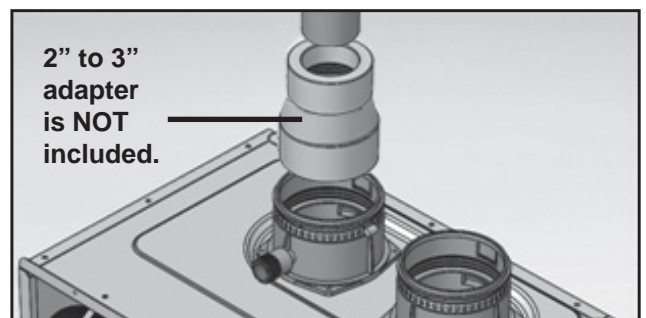



### 4.7.3 Single Venting

Read and Follow Sections 4.3 Guidelines First.

1. Insert the termination end cap into the intake air duct.
2. Provide two openings to allow for circulation of combustion air as specified by ANSI Z224.1/NFPA 54 or CAN/CGA B-149.1:

Model	MSTWW199
Maximum Input (BTU/H)	199,000
Indoor make up air is provided, a minimum free area of 1 in 2 per 1,000 BTU/H	199 in 2 14 1/4" (W) x 14 1/4" (H)



### 4.8 Vent / Air Pipe Termination

Note : For using pipe more than 1 elbow, reduce maximum allowable length

- 5 feet (1.5M) for each additional 3-inch 90-degree elbow
- 2.5 feet (0.75M) for each additional 3-inch 45-degree elbow
- 8 feet (2.4M) for each additional 2-inch 90-degree elbow
- 4 feet (1.2M) for each additional 2-inch 45-degree elbow
- The thickness of the wall vents installed : Min 4" ~ Max 20"

#### Vent Termination

##### 1. Rodent Screen Installation

- Install Rodent Screen and Vent Terminal (additional purchase), see Figure for appropriate configuration.
- After connecting vent/air inlet terminal, it is required to install screen for the terminal to prevent incoming of rodent, which might cause damage to the unit. (Extra purchase accessory 2/3" screen vent 1/4" mesh)

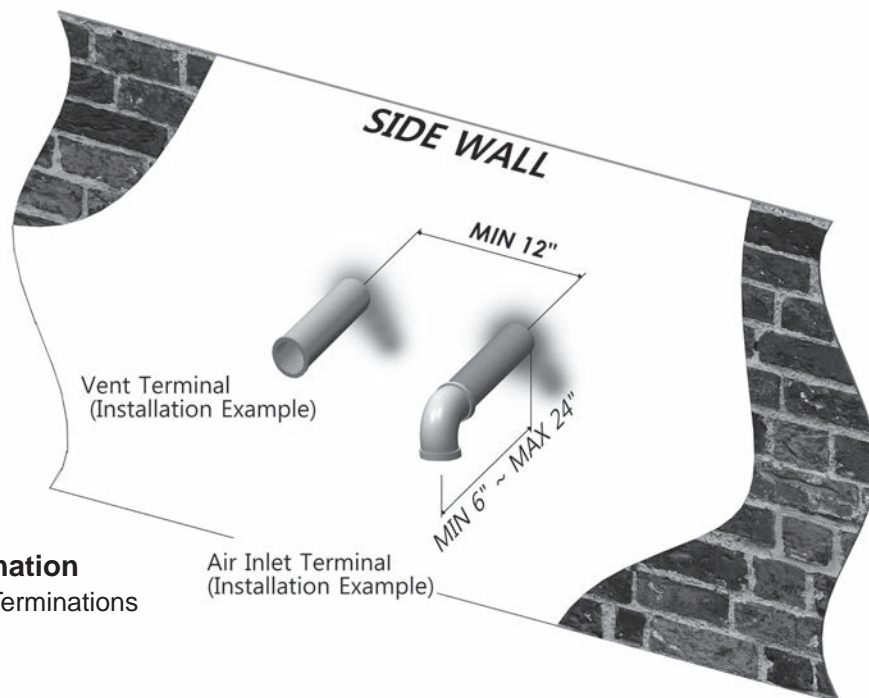

#### Horizontal Vent Termination

- Direct Vent - Sidewall Terminations

**4.8 Vent Pipe Termination (cont)**

**Horizontal Vent Termination (cont)**

- Direct Vent - Optional Sidewall Snorkel Terminations

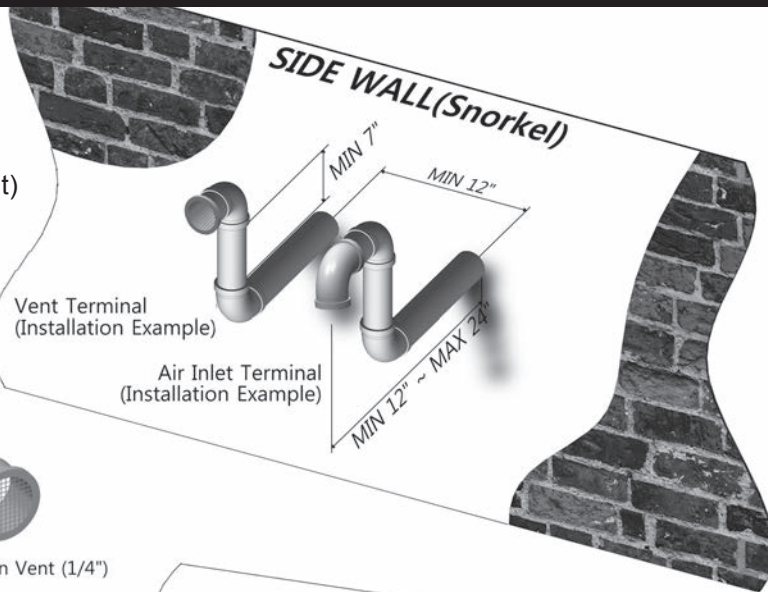

**Vertical Vent Termination**

- Direct Vent - Vertical Terminations with Sloped Roof

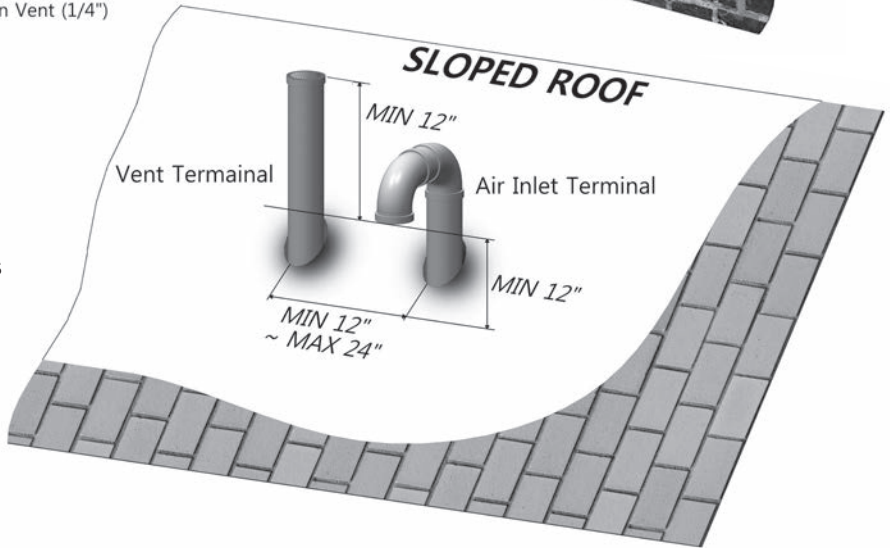

**Concentric Vent Termination**

- Direct Vent - Optional Horizontal and Vertical Concentric Vent

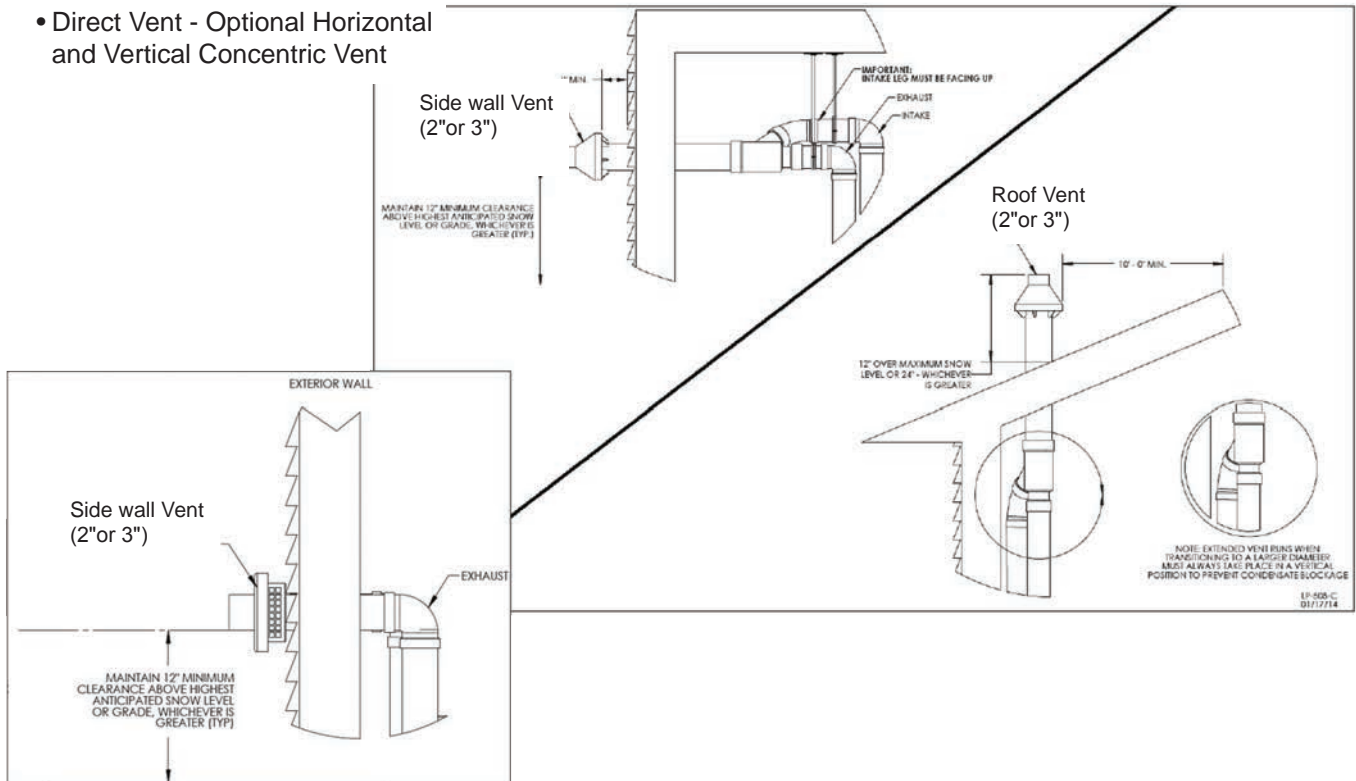

### 4.9 Gas Supply and Piping

Gas piping should be supported by suitable hangers or floor stands, not the appliance.

Review the following instructions before proceeding with the installation.

1. Verify that the appliance is fitted for the proper type of gas by checking the rating plate. Mascot ST will function properly at elevations up to 10,000 feet (3050 m). Refer to Section 4.12 for High Altitude Settings.
2. The maximum inlet gas pressure must not exceed 13" W.C. (3.2kPa). The minimum inlet gas pressure is 3.5" W.C. (1.0kPa).
3. Refer to [Table 8](#), [Table 7](#) and [Table 9](#) to size piping.
4. Run gas supply line in accordance with all applicable codes.
5. Locate and install manual shutoff valves in accordance with state and local requirements.
6. A sediment trap must be provided upstream of the gas controls.
7. All threaded joints should be coated with piping compound resistant to action of liquefied petroleum gas.
8. The appliance and its individual shutoff valve must be disconnected from the gas supply piping during any pressure testing of that system at test pressures in excess of 1/2 PSIG (3.45kPa).
9. The unit must be isolated from the gas supply system by closing its individual manual shutoff valve during any pressure testing of the gas supply piping system at test pressures equal to or less than 1/2 PSIG (3.45kPa).
10. The appliance and its gas connection must be leak tested before placing it in operation.
11. Purge all air from gas lines.

**⚠ CAUTION**

PRV (included) must be installed immediately at water heater outlet with no valves between.

**⚠ ATTENTION**

PRV (inclus) doit être installé immédiatement à sortie chaudière avec pas de vannes entre.

**⚠ WARNING:**

Open flame can cause gas to ignite and result in property damage, severe injury, or loss of life.

**NOTE:** The Mascot ST appliance and all other gas appliances sharing the gas supply line must be firing at maximum capacity to properly measure the inlet supply pressure. The pressure can be measured at the supply pressure port on the gas valve. Low gas pressure could be an indication of an undersized gas meter, undersized gas supply lines and/or an obstructed gas supply line.

SCHED 40 METAL PIPE CAPACITY FOR 1.50 SPECIFIC GRAVITY UNDILUTED PROPANE			
NOMINAL PIPE SIZE @ 11" W.C. INLET AND 0.5" W.C. PRESSURE DROP			
SIZE	1/2"	3/4"	1"
LENGTH	MAXIMUM CAPACITY IN THOUSANDS OF BTU PER HOUR		
20	200	418	787
40	-	287	541
60	-	231	434
80	-	197	372
100	-	175	330

**NOTES:** 1. Follow all local and national propane gas codes for line sizing and equipment requirements. 2. Verify that inlet gas pressure remains between 4 and 13 inches of water column before and during operation. Source: ANSI Z223.1-80 National Fuel Gas Code.

**Table 7. Nominal Pipe Size, Propane**

SCH 40 METAL PIPE CAPACITY FOR 0.60 SPECIFIC GRAVITY NATURAL GAS		
NOMINAL PIPE SIZE @ 0.30" W.C. PRESSURE DROP		
LENGTH	3/4"	1"
FT	CUBIC FEET OF GAS PER HOUR	
20	190	350
40	130	245
60	105	195
80	90	170
100		

**Table 8. Nominal Pipe Size, Natural Gas**

EQUIVALENT LENGTHS OF STRAIGHT PIPE FOR TYPICAL SCH 40 FITTINGS			
NOMINAL PIPE SIZE			
FITTING	1/2"	3/4"	1"
LINEAR FEET			
90° ELBOW	3.6	4.4	5.2
TEE	4.2	5.3	6.6

**Table 9. Equivalent Pipe Lengths**

- The gas connection fitting on the unit is 3/4" female NPT.
- The supply line must be sized for the maximum output of the water heater model being installed. If there are additional gas appliances from the main supply line, you must measure sizes of the supply line according to the COMBINED total maximum BTUH draw for the appliances as if they were all operating at the same time.
- Measure the length of the gas supply line from the gas meter to the Water Heater. Use the tables in this manual or refer to the gas line manufacturers sizing information to determine the correct supply pipe size.
- The gas shut-off valve in the gas supply line should be installed close to the unit.
- To facilitate any future maintenance, it is also recommended that an approved gas union fitting

be installed in the supply line between the shut-off valve and the 3/4" female NPT connection on the Water Heater.

- 1) Install an approved gas line pipe to gas line connection under the Water Heater. Include manual shut off valve and gas union connection, as shown.
- 2) Test gas pressure to make sure it meets the minimum standards and does not exceed the maximum standards for the water heater.
- 3) Leak test the gas line pipe before placing the unit in operation. Use approved leak detector liquid solutions only to check for leaks.

■ **Do not operate the water heater until all connections have been completed and the heat exchanger is filled with water.**

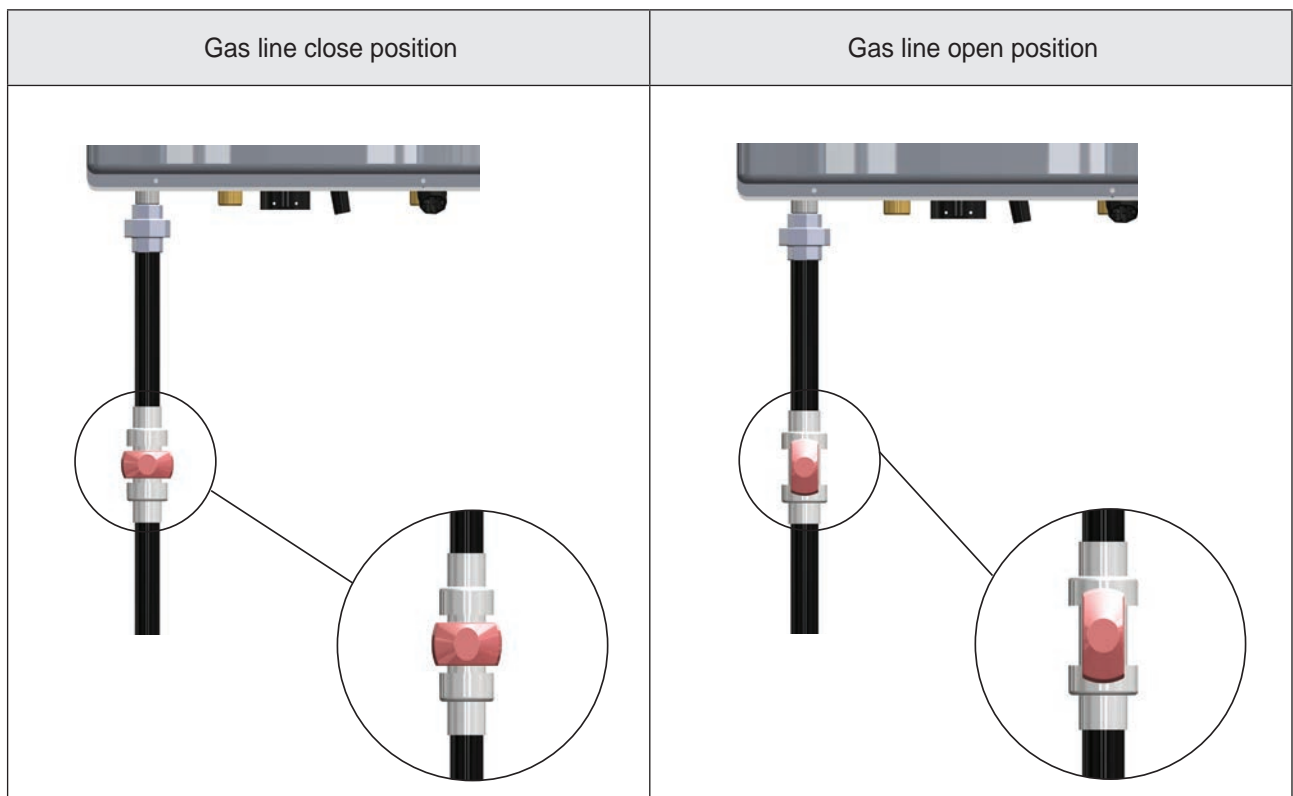

### 4.9 Gas Supply and Piping (continued)

- Water Heater MUST be installed downstream of the gas meter for adequate gas supply.

- Natural Gas piping installation.

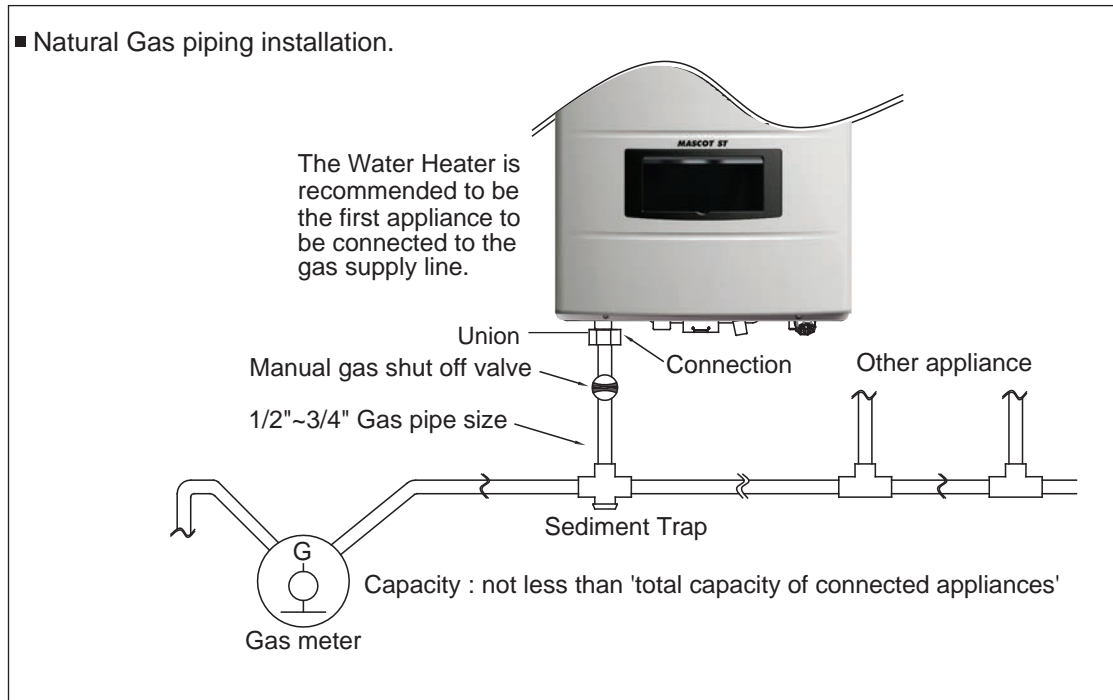

- Propane gas piping installation.

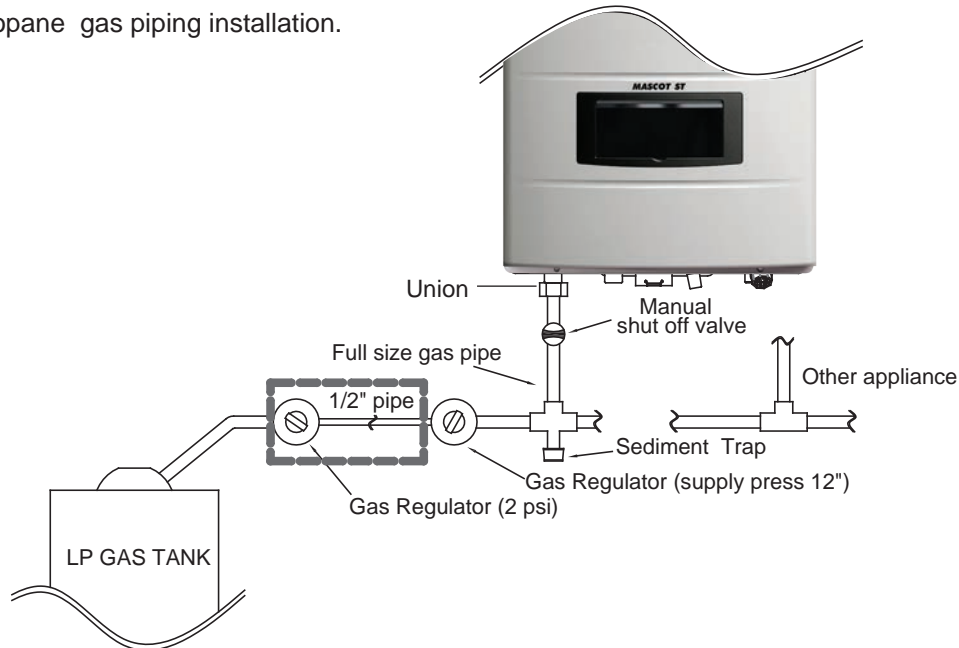



### 4.10 Gas Supply Pressure

■ Refer to the illustration. Check the gas inlet pressure measurement from inlet gas pressure port. (Loosen the port bolts before you check the gas inlet pressure.)

1. The appliance and its individual shutoff valve must be disconnected from the gas supply piping system during any pressure testing of that system at test pressures in excess of 1/2 psi (3.5 kPa).
2. The appliance must be isolated from the gas supply piping system by closing its individual manual shutoff valve during any pressure testing of the gas supply piping system at test pressures equal to or less than 1/2 psi (3.5 kPa).

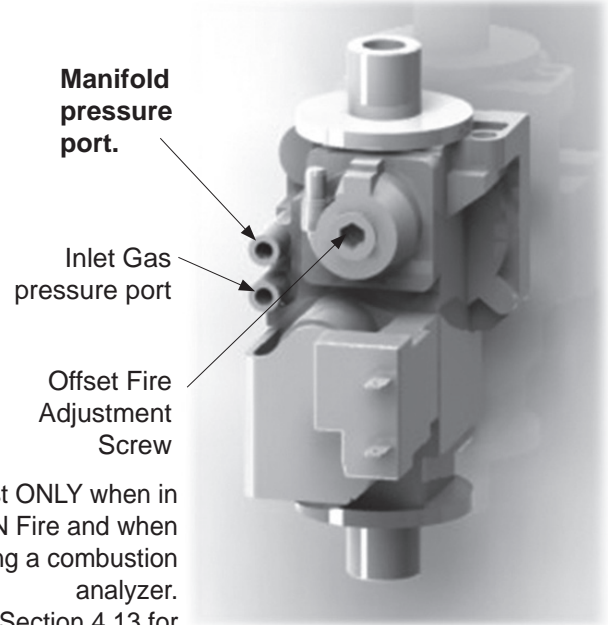

Adjust ONLY when in MIN Fire and when using a combustion analyzer. See Section 4.13 for step by step details.

Natural Gas		LP Gas	
Maximum Pressure	10.5" WC	Maximum Pressure	13.0" WC
Minimum Pressure	3.5" WC	Minimum Pressure	8.0" WC

**Table 11. Min and Max Inlet Gas Line Pressures**

### 4.11 Gas Setup and Adjustment

**For the Step by step process to measure CO<sub>2</sub> values on the Mascot ST, please refer to Step 16 thru Step 28 in Section 4.13 of this Installation Manual.**

**⚠ WARNING**

Installer is required to verify combustion settings as part of the installation process. CO should not exceed 300 ppm.

Standard Factory Setting is for MIN Fire. 9.0% CO<sub>2</sub> @ 0 - 2,000 ft altitude (Natural Gas).

	'LP' CO <sub>2</sub> Values		'NG' CO <sub>2</sub> Values	
	2" or 3" VENT		2" or 3" VENT	
MSTWW199	2" or 3" VENT		2" or 3" VENT	
0~2,000 ft	10.7	MAX	10	
	9.7	MIN	8.5	
2,000~5,000 ft	10.2	MAX	9.1	
	10.3	MIN	9.7	
5,000~8,000 ft	10.3	MAX	9.1	
	10.4	MIN	9.8	
8,000~10,000 ft	10.5	MAX	9	
	10.6	MIN	9.8	

**Table 10. CO<sub>2</sub> Values**

Manifold pressure		'NG' type combustibility	'LP' type combustibility
MSTWW199	MAX FIRE	-0.11" to -0.17" WC	-0.07" to -0.11" WC
	MIN FIRE	-0.10" to -0.16" WC	-0.06" to -0.10" WC

**Table 12. Manifold Pressures**



**4.12 Gas High Altitude Setting  
(no adjustment is needed below 2000 feet)**

The Mascot ST has been set up at the factory for altitudes of less than 2,000 ft, but it may be installed at elevations up to 10,000 ft for use with Natural Gas or Propane. If the installation is at an altitude of greater than 2,000 ft, then altitude settings need to be adjusted in the Installer Mode as describe below.

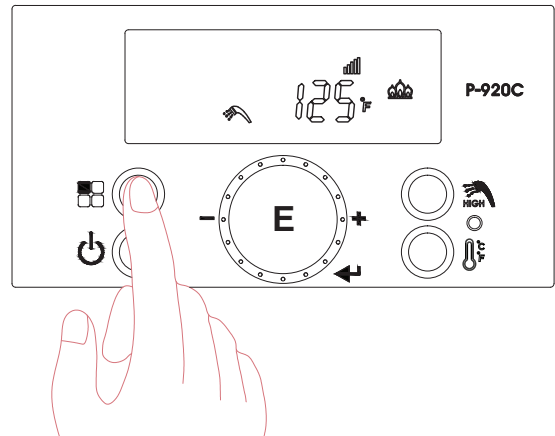
NOTE: Above 2,000 ft (610 m), the water heater will de-rate by 2-4% for each 1,000 ft (305 m) of altitude gain.



■ High Altitude settings (2,000 ~ 10,000 ft)

1. With the Power  turned OFF, press the 'Modes button'  for 5 seconds to get into the Installer Parameters Mode.

2. Turn the dial (E) until '9:HA' appears.

3. Press the dial (E).

4. Set the high altitude value by turning the dial.  
Refer to table.

<b>9:HA</b>	Choose the correct value from the following four options.
0 - 2	0 ~ 1,999 ft (0 - 609 m)
2 - 5	2,000 ~ 4,999 ft (610 - 1,523 m)
5 - 8	5,000 ~ 7,999 ft (1,524 - 2,438 m)
8 - 10	8,000 ~ 10,000 ft (2,439 - 3,048 m)

5. Press the dial again (E) to save the setting.

6. Press the 'Modes button'  for one second, to Save the number and to go back to initial status.



**4.13 Gas Conversion Kit**

**Laars Kit Document #4286**

**Kit # R20769**

The Laars Mascot ST condensing gas water heater is configured for Natural Gas (NG) from the factory. If your gas supply is Propane Gas (LP), your water heater can be converted to burn propane gas as follows:

**NOTICE**

The Natural Gas to Propane Conversion Kit (# R20769) for the Mascot ST, is not included in the original box. To order the conversion kit, please visit [laars.com/support](http://laars.com/support) to get the contact info for your nearest Laars Sales Representative.

**WARNING**

This conversion kit must be installed by a qualified service agency in accordance with the manufacturer's instructions and all applicable codes and requirements of the authority having jurisdiction. You must follow these instructions to minimize the risk of fire or explosion or to prevent property damage, personal injury or death. The qualified service agency is responsible for the proper installation of this kit. The installation is not proper and complete until the operation of the converted appliance is checked as specified in the manufacturer's instructions supplied with the kit. Installation must conform with local codes and the latest edition of the National Fuel Gas Code, ANSI Z223.1 and CAN-B149 Failure to follow instructions could result in serious injury or property damage. The qualified agency performing this work assumes responsibility for gas conversion.

**CAUTION**

This water heater has already been set to burn natural gas, but can be converted to burn propane gas. Before operating the heater, verify the type of gas supplied to your water heater

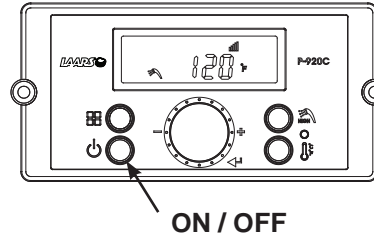

To convert from natural gas to propane gas

**Steps 1 thru 30**

1. Turn **OFF** the Mascot ST. The **ON / OFF** button is located at the bottom left of the Control Display.
2. Turn **OFF** the GAS and WATER supply to the Mascot ST (valves are located on the plumbing pipes.)
3. Using a Phillips screwdriver, remove the 4 screws on the front cover. See Figure A.
4. Locate the AGM (Air Gas Mixture) Chamber. See Figure B. In order to open up the AGM Chamber and complete this conversion, the Ignition Transformer and the Combustion Air Intake Assembly must be removed.
5. The Ignition Transformer will lift and pop from it's location on the side wall. It is designed to do this. Let it hang and do not disconnect the wires from the transformer.
6. Then remove the Combustion Air Intake Assembly by removing the screw at the bracket ( See Figure C) and the screw holding the Intake Assembly to the AGM cover. The bracket then hinges outward so that the entire Intake Assembly can be removed as one piece.
7. Using a short Phillips screwdriver, remove the 2 screws from the AGM Actuator. Do not disconnect the actuator.

Keep all screws and washers. Refer to Figure C.

8. **IMPORTANT!** Using a paint pen or a sharp object, place a mark onto the Inner Mount near the top screw (there are 3 screws). See Figure C. This 'Top' mark that you make will be very important during reassembly.

Original <b>Natural Gas (NG)</b>		Conversion <b>Propane Gas (LP)</b>	
Needle / Ring Ass'y 9.7 mm (0.382")	Orifice 9.5 mm (0.374")	Needle / Ring Ass'y 6.8 mm (0.268")	Orifice 7.0 mm (0.276")

**Table A. Natural gas to Propane gas conversion parts**

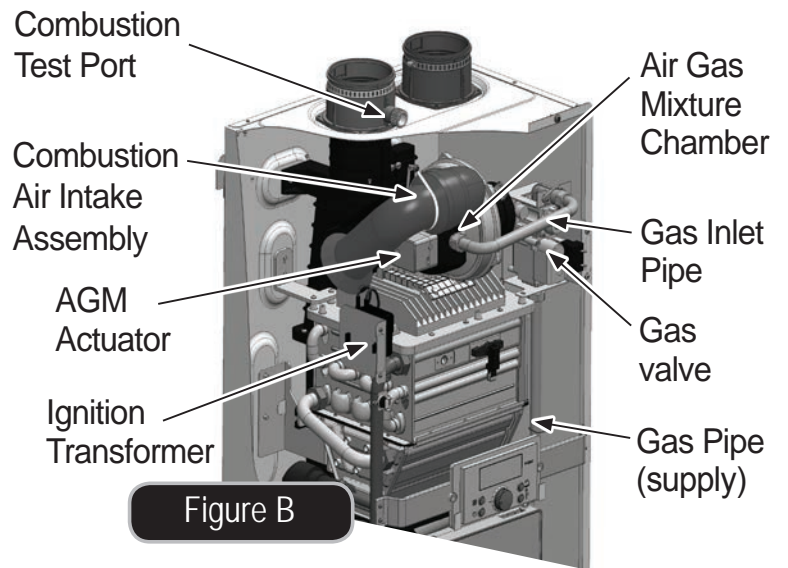
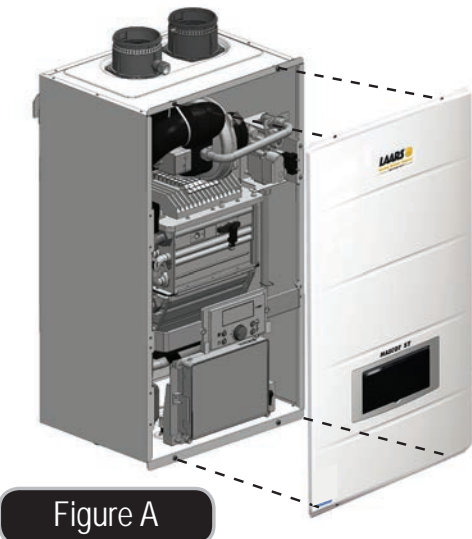

**IMPORTANT!**  
Be sure to place an orientation mark at the top of the Inner Mount for ease of reassembly.

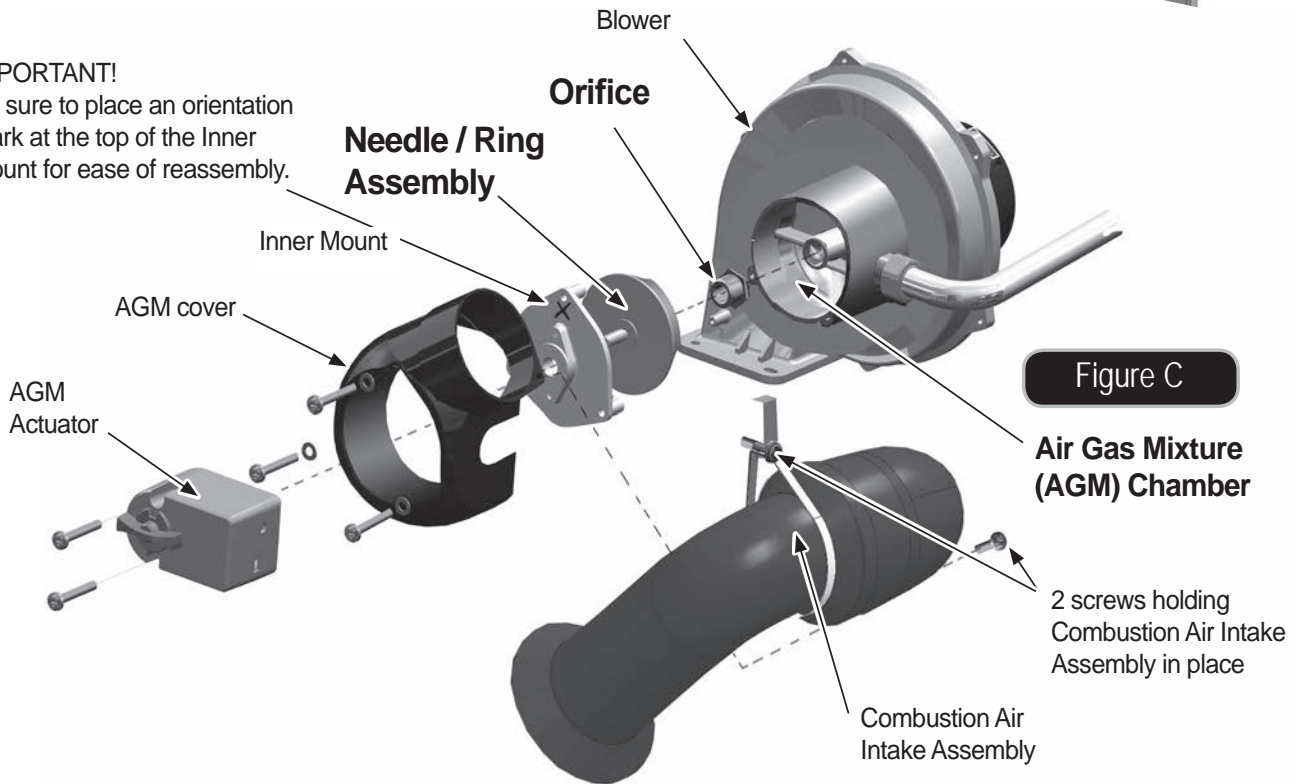

9. Then remove the 3 screws. The AGM Cover and the Inner Mount will separate away from the blower. Keep track of this disassembly as you will need to re-assemble exactly as it comes apart. Keep all screws and washers.
10. Remove the 'Needle / Ring Assembly' (NG) from the Inner Mount.
11. Remove the Orifice (NG) from the AGM Chamber using a 19 mm wrench.
12. Thread the new Orifice (LP) into place and tighten using the 19 mm wrench.
13. Thread the 'Needle/ Ring Assembly' (LP) into the Inner Mount.
14. Re-assemble everything, using all screws previously removed. Be sure that the Inner Mount has it's Top Mark at the Top.

**⚠ WARNING**

This conversion shall be installed by a qualified service agency in accordance with the manufacturer's instructions and all applicable codes and requirements of the authority having jurisdiction. If the information in these instructions is not followed exactly, a fire, an explosion or production of carbon monoxide may result causing property damage, personal injury or loss of life. The qualified service agency is responsible for the proper and complete installation of this kit. The installation is not proper and complete until the operation of the converted appliance is checked as specified in the manufacturer's instruction supplied with the kit.

### 4.13 Gas Conversion Kit

ON	OFF	#
MIN Fire	Normal Operation	7
MAX Fire	Normal Operation	6
NG Natural	LP Propane	5
Inlet flow <u>Over-ride</u> ON	Inlet flow <u>Over-ride</u> OFF	4
Normal Operation	Do Not Touch	3
Normal Operation	Do Not Touch	2
Normal Operation	Do Not Touch	1

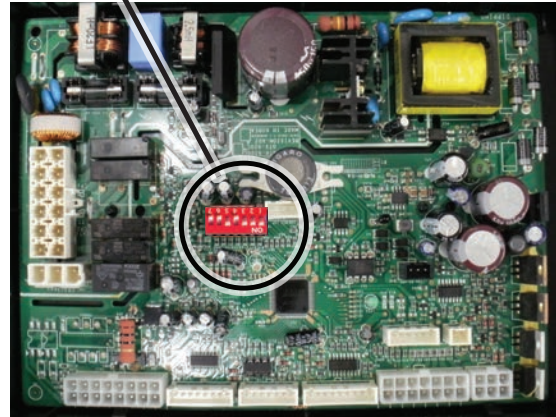

**Table B** DIP Switch Settings

15. Per Table B, set DIP Switch **5 to OFF** for LP Propane.
16. Turn **ON** the GAS and WATER supply to the Mascot ST.
17. Turn **ON** the Mascot ST. 

**NOTE:** If your Mascot ST is installed at an altitude greater than 2,000 ft, then the correct altitude setting should have been set previously and saved within the Control Display. If this has not been done, Refer to Section 4.12 of the Mascot ST Install and Operating Manual (document #1316) before continuing with this Gas Conversion.

18. Connect a manometer to the manifold pressure port. See Figure D. For dual port manometers, use the positive pressure side. Check for proper manifold gas pressure. Refer to Table D. You must have acceptable gas manifold pressure before continuing.
19. Establish a call for heat. You may need to disconnect the outdoor reset if you are making this gas conversion during warm weather.
20. Setup your combustion analyser and place the sensor into the combustion test port.
21. Per **Table B for Max Fire**, change dip switch 6 to ON and 7 to OFF. The unit will cycle up to MAX fire.
22. WAIT for your combustion analyser to stabilize. This may take up to 3 minutes depending on your combustion analyser. Then check the CO<sub>2</sub> measurement for MAX fire. Refer to Table C for acceptable MAX fire combustion readings Do NOT adjust CO<sub>2</sub> at MAX Fire. ONLY in MIN Fire, so...
23. Per **Table B for MIN Fire**, change dip switch 6 to OFF and 7 to ON. The unit will cycle down to MIN Fire.
24. WAIT for your combustion analyser to stabilize. Then check the CO<sub>2</sub> measurement for MIN fire. Refer to Table D for acceptable MIN fire combustion readings
25. Open the Gas Valve Adjustment Port by removing the cap screw with a 4mm Allen wrench.

26. Then use the 4 mm Allen wrench to make a minor adjustment (1/8 turn) to either increase or decrease CO<sub>2</sub>.

27. It may be necessary to go back and forth between HI Fire and LOW Fire several times (and making adjustments only at LOW Fire), before CO<sub>2</sub> at both are within acceptable levels. Be sure to put the adjustment port cap screw back onto the valve when done.

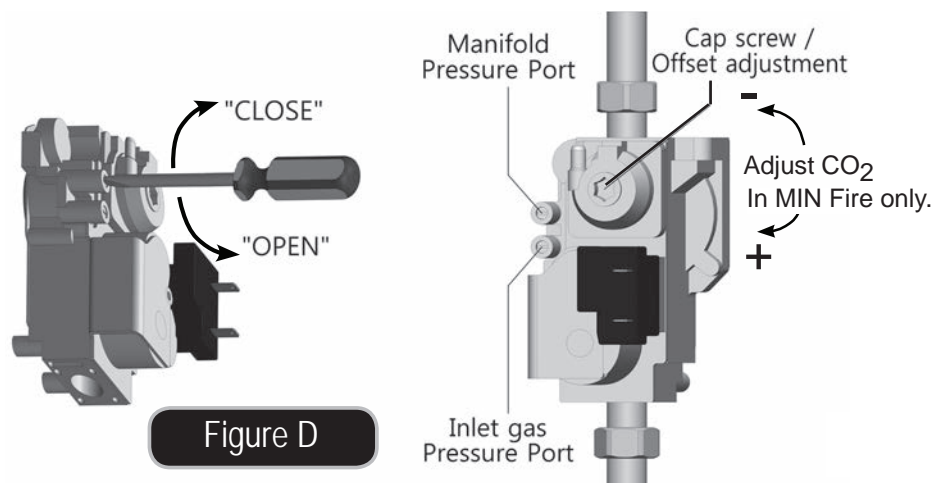

**Figure D**

28. Once the CO<sub>2</sub> for both MIN and MAX Fire are acceptable per Table C, set DIP switches 6 and 7 to the OFF position for Nominal Fire (normal operation).
29. Write in the correct Conversion Date and the Technicians Name to the included gas conversion sticker. See Figure E. Then apply that sticker adjacent to the rating plate.
30. Put the water heater cover back on and assemble/ tighten the 4 screws that hold the cover in place.

High Altitude Setting level	'LP' CO <sub>2</sub> Values		'NG' CO <sub>2</sub> Values
MSTWW199	2" or 3" VENT		2" or 3" VENT
0~2,000 ft	10.7	MAX	10
	9.7	MIN	8.5
2,000~5,000 ft	10.2	MAX	9.1
	10.3	MIN	9.7
5,000~8,000 ft	10.3	MAX	9.1
	10.4	MIN	9.8
8,000~10,000 ft	10.5	MAX	9
	10.6	MIN	9.8

Table C

Manifold pressure		'NG' type combustibility	'LP' type combustibility
MSTWW199	MAX FIRE	-0.11" to -0.17" WC	-0.07" to -0.11" WC
	MIN FIRE	-0.10" to -0.16" WC	-0.06" to -0.10" WC

Table D

This unit was converted on \_\_\_/\_\_\_/\_\_\_ to \_\_\_ gas with kit # \_\_\_\_\_ by \_\_\_\_\_ (name and company \_\_\_\_\_ accountable) \_\_\_\_\_

Cette unité a été converti \_\_\_/\_\_\_/\_\_\_ ten \_\_\_ gaz en utilisant le kit numéro \_\_\_\_\_ par \_\_\_\_\_ (nom et société \_\_\_\_\_ responsable) \_\_\_\_\_

Figure E (Conversion label)

**⚠ AVERTISSEMENT**

Ce conversion doit être installé par un organisme de service conformément aux instructions du fabricant et tous les codes et les exigences de l'autorité compétente. Si les informations contenues dans ces instructions n'est pas suivi à la lettre, un incendie, une explosion ou de la production de monoxyde de carbone mais résultat causant des dommages matériels, des blessures ou des pertes de vie. Le service est responsable pour la bonne et complète l'installation de ce kit. L'installation n'est pas correcte et complète jusqu'à ce que le fonctionnement de l'appareil converti est vérifiée comme spécifié dans le manuel d'instruction fourni avec le kit.



### 4.14 Plumbing Guidelines.

- Ensure pipe material is suitable for the local codes and industry standards.
- The pipe must be cleaned and without any debris.
- Do not apply torch heat within 12" of the bottom connections of the unit.
- The pipe size used for supply heating water should be the same size used for the return heating water.
- The size of the hot water pipe should be 3/4" diameter.
- Isolation valves(Shutoff valve) will be used.
- All piping should be insulated.

■ **Applicable Backflow Preventer**

- Apply a backflow preventer valve in the make-up water supply (water Inlet) to the unit as required by local codes.

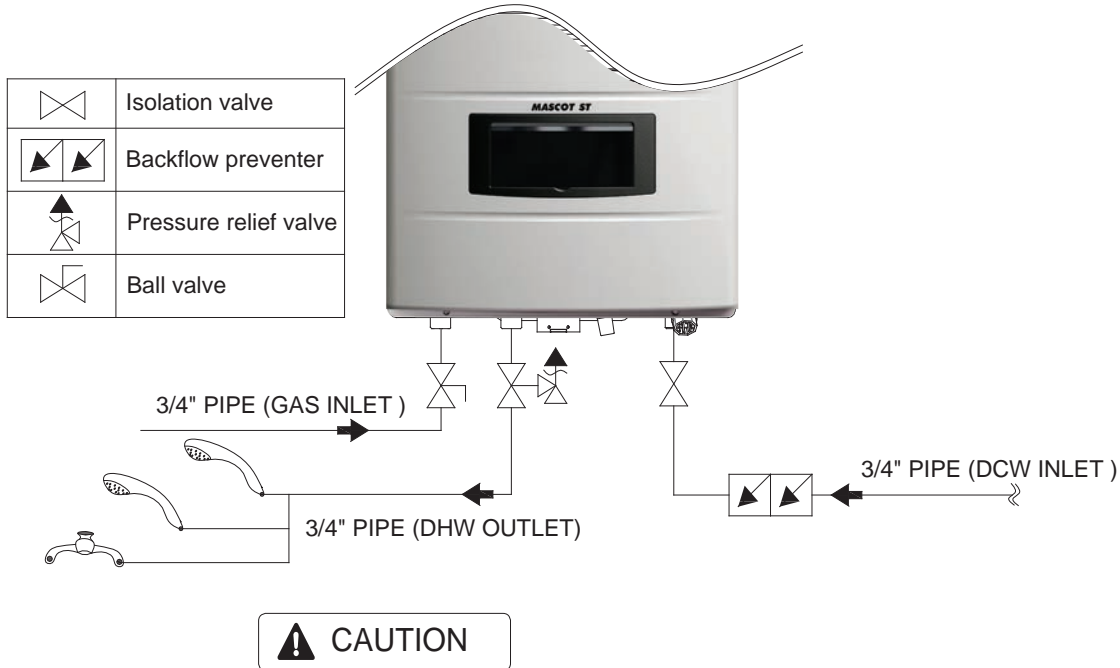

- Use at least the MINIMUM pipe size for all Water Heater loop piping
- DWH pipe minimum size: 3/4"

When using external recirculation mode with the built-in pump, observe the following maximum recirculation pipe lengths including fittings (3/4" pipe is recommended):

- 1/2" Pipe- 100' (30m) of equivalent length
- 3/4" Pipe- 500' (150m) of equivalent length. Lengths in excess of these limits will require an external recirculation pump.

### Water Quality

Potable water is defined as drinkable water supplied from a utility or from a well, in compliance with EPA secondary maximum contaminant levels (40 CFR Part 143.3) as shown in Table X. Water quality must be within these maximum allowable parameters. If your water contains contaminants in quantities greater than outlined by EPA, then water treatment is required and additional maintenance may also be required. If you suspect that your water is contaminated in any way, discontinue use of the appliance and contact a qualified technician.

Contaminant	Maximum Allowable Level	Contaminant	Maximum Allowable Level
Total Hardness	200 mg/l (12 grains/gallon)	Manganese	0.05 mg/l
Aluminum	0.05 to 0.2 mg/l	pH	6.5 - 8.5
Chloride	250 mg/l	Sulfate	205 mg/l
Copper	1 mg/l	Total Dissolved Solids (TDS)	500 mg/l
Iron	0.3mg/l	Zinc	205 mg/l

**Table 13. Water Quality Specifications**

### 4.15 Disposal of Condensate

- High efficiency gas condensing Water Heaters create condensation when operating. Condensation has acidic (pH) of approximately 4-5.
- Condensate must be drained in accordance with all local regulations. Follow your local code with regards to the disposal of condensation.
  - One of 4 disposal methods must be followed**
  - 1. to floor drain
  - 2. to neutralizer drain (optional kit \*)
  - 3. to laundry tub
  - 4. to condensate pump (field supplied)
- If a neutralizer is installed, periodic replacement of the lime stone (or neutralizing agent) will be required. The rate of depletion of the lime stone varies upon usage of the Water Heater. During the first year of operation, please check the neutralizer every few months for depletion.
- Apply only corrosion-resistant materials for the condensate drain lines such as 1/2" PVC, CPVC, Polypropylene pipe or included plastic hose.



Condensate drain pipe

**⚠ NOTICE**

For Category II and IV water heaters, be installed so as to prevent accumulation of condensate; and  
 For Category II and IV water heaters, where necessary, have means provided for drainage of condensate.

**⚠ AVIS**

les chaudières de catégories II et IV doivent être installées de façon à empêcher l'accumulation de condensat; et  
 si nécessaire, les chaudières de catégories II et IV doivent être pourvues de dispositifs d'évacuation du condensat.

**⚠ CAUTION**

Condensate is mildly acidic (pH=5), and may harm some floor drains and/or pipes, particularly those that are metal. Ensure that the drain, drainpipe, and anything that will come in contact with the condensate can withstand the acidity, or neutralize the condensate before disposal. **Damage caused by failure to install a neutralizer kit or to adequately treat condensate will not be the manufacturer's responsibility.**

\* Contact Laars to order Kit# A2123601

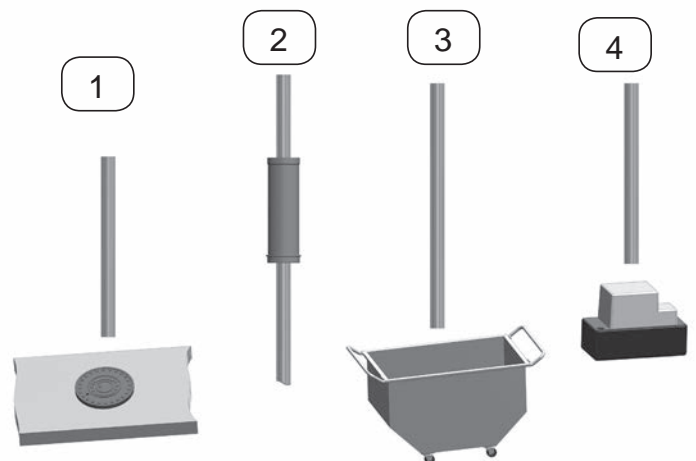



## 4.16 Pressure Relief Valve

### ⚠ WARNING

- An approved 'Pressure Relief Valve' must be included in this installation. The Valve must be an approved ASME HV Relief Valve, installed on the DHW supply line for domestic hot water loop as close to the unit as possible. (Valve size 3/4", maximum 150psi).



## 4.17 Electrical Wiring Connections

### ⚠ WARNING

- Install wiring and electrically ground Water Heater in accordance with authority having jurisdiction or in the absence of such requirements follow the National Electrical Code, NFPA 70, and/or CSA C22.1 Electrical Code-Part 1 in Canada.

- **ELECTRICAL SHOCK HAZARD** — For your safety, turn off electrical power supply at service entrance panel before making any electrical connections to avoid possible electric shock hazard. Failure to do so can cause severe personal injury or death.

- Do not disconnect the power supply when the unit is in normal operation.
- Damage caused by freezing is not covered under the warranty.
- Manual(Rocker) switch maximum allowable current for each circulator is 16 amps at 125VAC.  
( Housing : Nylon #66 UL 94V-2 , Rocker : Nylon #66 UL 94V-2, Terminal : Copper Alloy )

- This appliance must be electrically grounded. Ensure the electrical receptacle, in which the water heater will be plugged into, is properly grounded; if wiring directly.
- Do not attach the ground wire to the gas or the water piping as plastic pipe or dielectric unions may isolate the Water Heater electrically.
- The wiring diagrams contained in this manual are for reference purposes only.
- Refer to this diagram and the wiring diagram of any controls used with the Water Heater. Read, understand and follow all wiring instructions supplied with the controls.

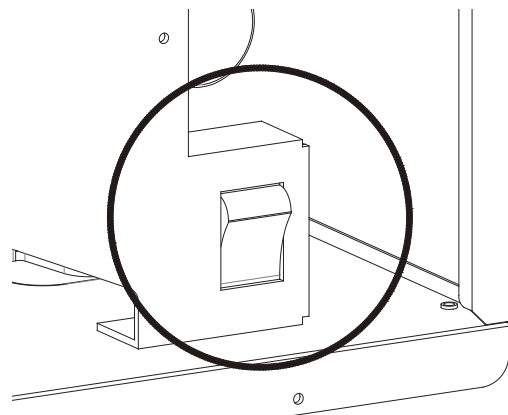

### 4.18 DIP Switches

- There is one set of DIP switches.
- DIP switches 6 and 7 must be set to OFF when operating the water heater normally.

DIP Switch Function		OFF	ON
1-3	Machine power	Do NOT Move.	
4	<b>OVER-RIDE</b> Inlet DHW Flow Limiter	OFF	ON
5	Propane or Natural Gas	LP	NG
6	Max.	Normal	MAX Fire
7	Min.	Normal	MIN Fire

Table 15. Dip Switches



Shown in it's actual orientation in the unit.

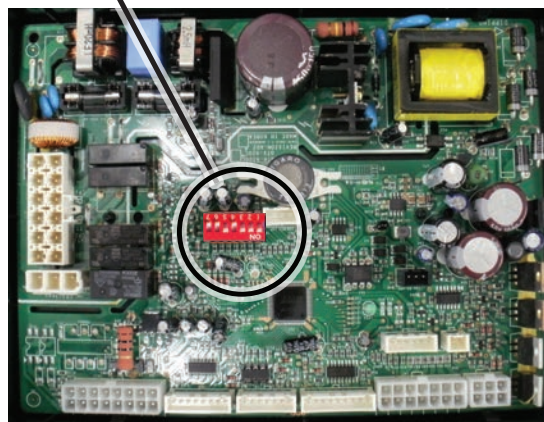

Maximum flame detecting voltage	2.4V
Pre-purge time (Tp)	Maximum 10s, minimum 1s
Safety Time (igniting time) (Ts)	3.5s
Igniting interval time	<10s
Post-purge time (Tip)	180s
Over-heating 1,2,3 protection detection time	<1s
Temperature sensor fault detection time	<2s
Nr. of trial for ignition (Ntl)	10
DHW water SET temperature range	35°C~ maximum DHW setpoint temperature(default: 60°C)
DHW water OFF temperature	DHW target temperature + DHW differential temperature(15°C)
DHW water ON temperature	Below DHW target temperature +3°C
DHW water ON minimum water flow	2ℓ(12Hz)
DHW water OFF minimum water flow	1.5ℓ(8Hz)

Table 14. System Control Settings

### 4.19 Wiring Diagram

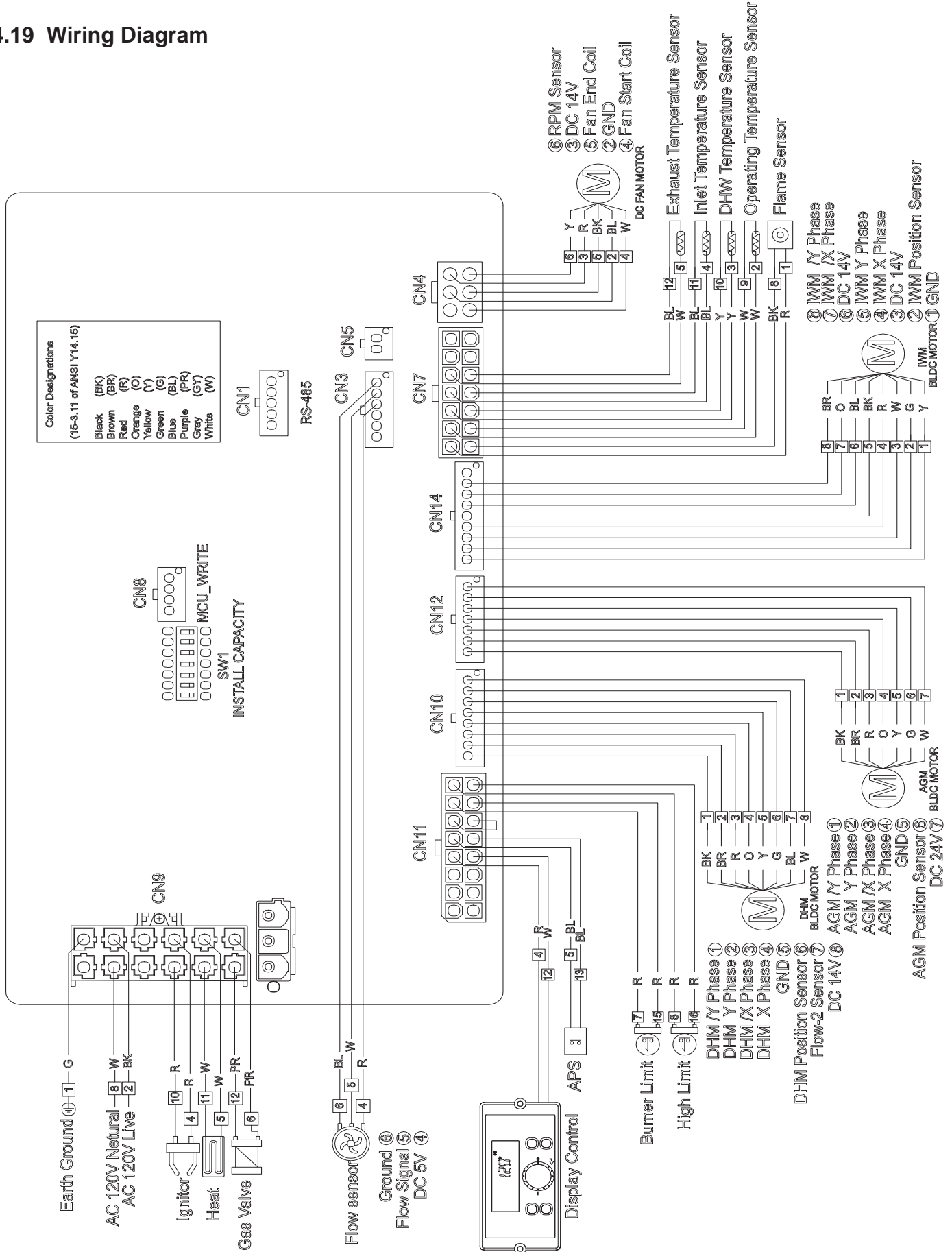

Figure 3. Wiring Diagram

### 4.20 Ladder Diagram

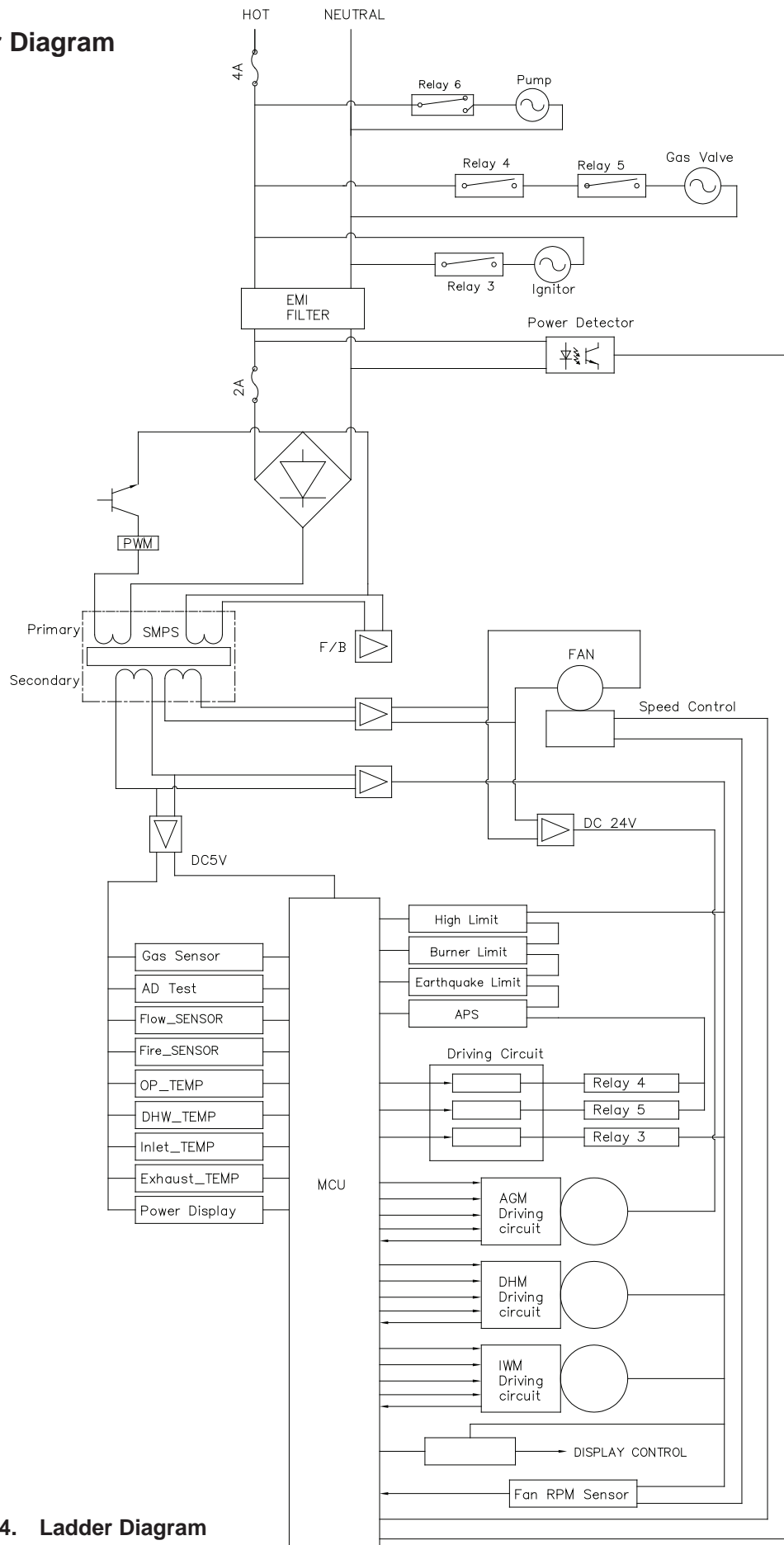

Figure 4. Ladder Diagram

## 4.21 Electrical Connections

Connector			Descriptions	HT SELV
#, Location, Type	PIN	Label		
CN9 65001WS-12	1	-	CASE GROUND	-
	2	L	Power Supply Line	HT (120VAC)
	3	CP1	Not Used	HT (120VAC)
	4	IT	Igniter	HT (120VAC)
	5	L(HT)	Heater	HT (120VAC)
	6	GV	Gas Valve	HT (120VAC)
	7		EARTH GROUND	HT (120VAC)
	8	N	Power Supply Neutral	HT (120VAC)
	9-12		AC Power COM Line	HT (120VAC)
CN1 SMW250-03	1	RS-485	RS485 +	SELV (5VDC)
	2		RS485 -	SELV (5VDC)
	3		-	-
CN4 LWD1140-06	1	FAN	Not Used	-
	2		GND	SELV (30VDC)
	3		VDD	SELV (14VDC)
	4		Fan power(start coil)	SELV (30VDC)
	5		Fan power(end coil)	SELV (30VDC)
	6		Fan speed feedback signal	SELV (14VDC)
CN8 SMW250-04	1	MCU ISP	GND	SELV (5VDC)
	2		ISP /Reset port	SELV (5VDC)
	3		ISP TOOL0 Data port	SELV (5VDC)
	4		VCC	SELV (5VDC)
CN11 LWD1140-16	1	HWL	Not Used	-
	8			
	2	LWL	Not Used	-
	10			
	3	HD	Not Used	-
	11			
	4	TH	Connect to the Display Control(Thermostat)	SELV (14VDC)
	12			
	5	APS	Air Pressure Switch	SELV (14VDC)
	13			
	7	BL	Burner Limit	SELV (14VDC)
	15			
8	HL	High Limit	SELV (14VDC)	
16				

Connector			Description	HT SELV
#, Location, Type	PIN	Label		
CN7 LWD1140-14	1	F.S	Flame Detect Sensor	SELV (5VDC)
	8			
	2	OP.S	Operation water temperature sensor	SELV (5VDC)
	9			
	3	DH.S	DHW temperature sensor	SELV (5VDC)
	10			
	4	I.S	Inlet water temperature sensor	SELV (5VDC)
	11			
	5	BG.S	Exhaust temperature sensor	SELV (5VDC)
	12			
	6	ST.S	Not Used	-
	13			
	7	SP.S	Not Used	-
	14			
CN12 SMW250-07	1	AGM	AGM Stepper motor coil /Y phase	SELV (24VDC)
	2		AGM Stepper motor coil Y phase	SELV (24VDC)
	3		AGM Stepper motor coil /X phase	SELV (24VDC)
	4		AGM Stepper motor coil X phase	SELV (24VDC)
	5		GND	SELV (24VDC)
	6		AGM Stepper motor position	SELV (14VDC)
	7		VDD	SELV (24VDC)
CN10 SMW250-08	1	DHM	DHM Stepper motor coil /Y phase	SELV (14VDC)
	2		DHM Stepper motor coil Y phase	SELV (14VDC)
	3		DHM Stepper motor coil /X phase	SELV (14VDC)
	4		DHM Stepper motor coil X phase	SELV (14VDC)
	5		GND	SELV (14VDC)
	6		DHM Stepper motor position	SELV (14VDC)
	7		Not Used	SELV (14VDC)
	8		VDD	SELV (14VDC)
CN14 SMW250-09	1	IWM	GND	SELV (14VDC)
	2		IWM Stepper motor position	SELV (14VDC)
	3		VDD	SELV (14VDC)
	4		IWM Stepper motor coil X phase	SELV (14VDC)
	5		IWM Stepper motor coil Y phase	SELV (14VDC)
	6		VDD	SELV (14VDC)
	7		IWM Stepper motor coil /X phase	SELV (14VDC)
	8		IWM power IWM Stepper motor coil /Y phase	SELV (14VDC)
	9		Not Used	-
CN3 SMW250-06	1	WPS	Not Used	SELV (5VDC)
	2		Not Used	SELV (5VDC)
	3		Not Used	SELV (5VDC)
	4	FLUX1	VCC	SELV (5VDC)
	5		Water Flow Sensor	SELV (5VDC)
	6		GND	SELV (5VDC)
CN5 SMW250-10	1	RPM	FAN RPM Check	SELV (5VDC)
	2		GND	SELV (5VDC)



**SECTION 5. Control Display and Operation**

**5.1 Control Dial and Buttons**

The Control Display

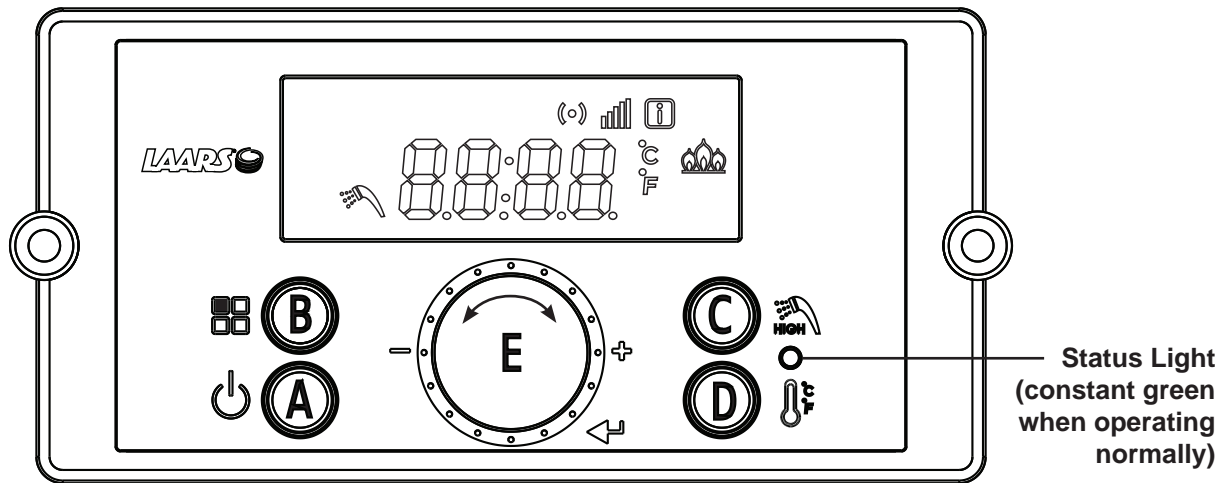

**The Control Display** has a Control Dial (E), 4 buttons (A, B, C, D), and a Liquid Crystal Display (with 72 back-lit segments). This section of this manual gives instruction on how to navigate into the many functions of the Mascot ST and to change temperature set points, set system variables and controller parameters.

Buttons			Functionality	
			PRESS (Tap)	PRESS and HOLD (5 seconds)
A		Display Power	Turns Control Display <b>ON/OFF</b>	
B		Modes	Tap to return to menu	(If Display Power was On ) <b>Status Display Mode</b> (If Display Power was Off ) <b>Installer Mode</b>
C		Hot Water	<b>DHW Set-Point LOW Range</b> 95 - 120°F (35 - 49°C)	<b>DHW Set-Point HIGH Range</b> 121 - 140°F (49.5 - 60°C)
D				<b>Toggle (°C / °F)</b>
E		Scroll / Select	Turn to scroll, tap to select (clockwise or counterclockwise)	

SECTION 5. Control Display and Operation

5.2 LCD Overview

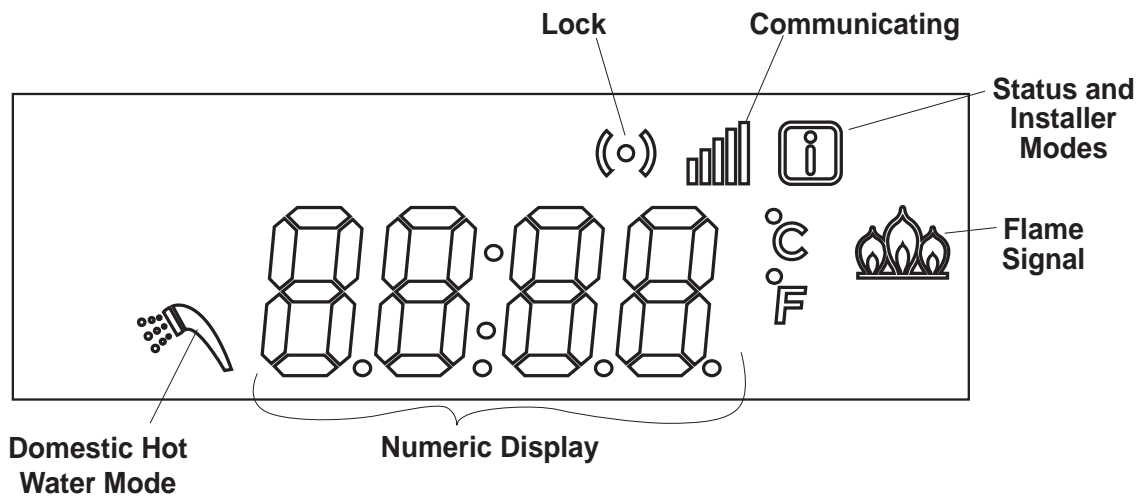

Lock mode	Buttons-locked mode icon
Communication	Communication icon
Status and Installer mode	The Status Mode or the Installer Mode is Active (all parameters)
Flame signal	Flame Signal icon
Numeric Display	Number and character display, to display all parameters
DHW mode	Water heater Set Point, can be adjusted

The LCD will illuminate when a user action is detected (a button is pressed) and will turn back off after 20 seconds.

\* NOTE: The display will not allow changes when the lock mode ((⊙)) is activated.

To exit the Lock mode, press the  button.

**⚠ WARNING**

Do not use this appliance if any part has been under water. Immediately call a qualified service technician to inspect the appliance and to replace any part of the control system and any gas control that may have been under water.



**SECTION 5. Control Display and Operation**

**5.3 Operating Mode**

■ Operating Mode

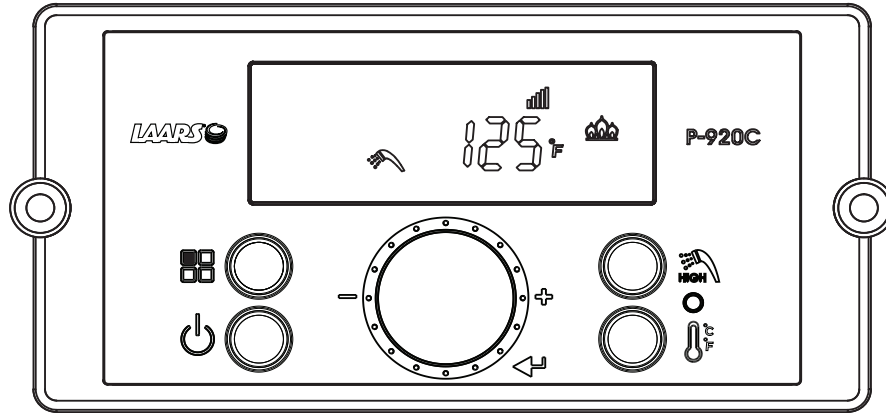
After the Power is turned on, and/or the Control Display is turned on , the Control Display will go through a 'Start Up' checklist and briefly show a sequence of diagnostic codes before entering into the 'Operating Mode'. It will then display the following information.



Indicate	Example
Current DHW temperature	125°F
If the flow is present	
If flame detected	
Temperature sign Celsius or Fahrenheit letter	°C or °F
Communication state indicate	

SECTION 5. Control Display and Operation

5.4 Status Display Mode

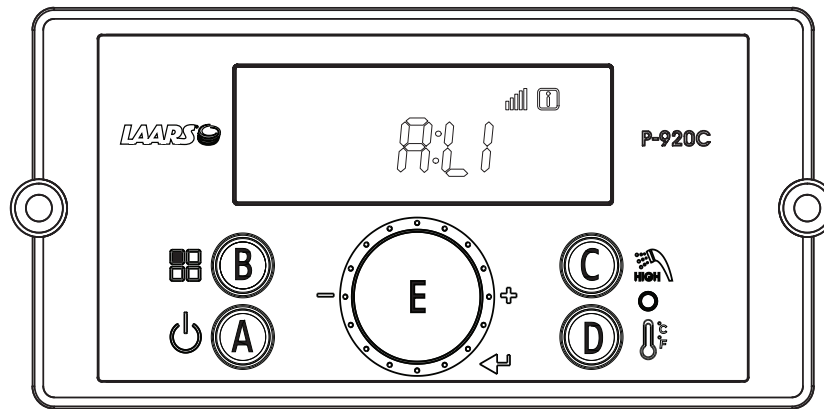

Index	Parameter	Description	
<b>A: Li or A: GA</b>	Flow 1	Current flow value(Li: L/m, GA: GPM)	
<b>b: Fr</b>	Fan rpm	Current fan rpm value	
<b>C: Lc</b>	Lock Mode	Lock mode is used(On) or unused(oFF)	
<b>d: OP</b>	OP Temperature	Current Operating Temperature	
<b>E: dH</b>	DHW temperature	Current DHW temperature	
<b>F: Eh</b>	Exhaust Temperature	Current Exhaust temperature	
<b>h: In</b>	Inlet Temperature	Current Inlet Temperature	
<b>L:rt</b>	Running Time	Display Running Time	
<b>L:rt</b>	<b>1: PH</b>	Power Supply Time	Power Supply Time: 100 hour increments
	<b>2: rh</b>	Burner Operating Time	Burner Operating Time: 1 hour increments
	<b>3: rH</b>	Burner Operating Time	Burner Operating Time: 1,000 hour increments
	<b>4: It</b>	Ignition Attempts Number	Ignition Attempts Number: 10 times unit displayed
	<b>5: IH</b>	Ignition Attempts Number	Ignition Attempts Number: 10,000 times unit displayed
<b>J: AG</b>	AGM Position	AGM Parameter calibration	

**To change any of the above listed Status Parameters,**

Press and Hold Button B  to get into the Status Display Mode.

Rotate Dial E until you find the Parameter that you wish to change. Tap Dial E to enter that Parameter.

Adjust to the setting that you require and then press (tap) Dial E to save and to Exit.

## SECTION 5. Control Display and Operation

## 5.5 DHW Set Point Change Mode

The Mascot ST has a built in **INLET** DHW Flow Limiter and will automatically adjust the DHW flow rate up or down based on DHW outlet temperature at the inlet side of the water heater. If the temperature drops below the DHW setpoint, and the Mascot ST is at full fire, the inlet flow to the heat exchanger will be reduced. Therefore, the DHW outlet temperature will begin to rise to the desired setpoint. If the temperature begins to rise above the setpoint the flow will increase until full flow is reached. This feature ensures that the DHW is always the ideal temperature for the user.

If this feature is not desired, then the 'over-ride' to this feature must be turned ON. To turn ON the over-ride to the INLET DHW Flow Limiter. **Refer to Section 4.18**

1. Turn off the power to the Control Display.
2. Move DIP switch 4 to the OFF Position.

#### ■ DHW Set Point Change Modes

The display shows the following information when changing water heating temperature set points.

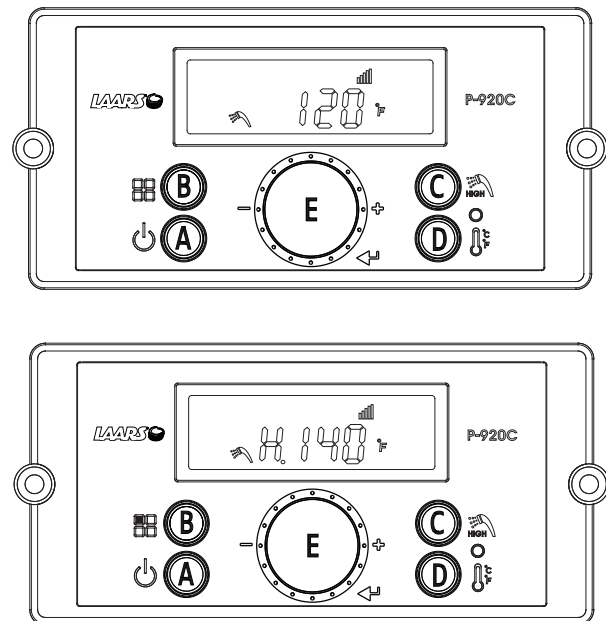

Indicate	Example
Current DHW set-point temperature	120°F
Temperature sign Celsius or Fahrenheit letter	°C or °F
If water heater display is communicating with the main controller normally, the communication icon will be indicated.	
When DHW set-point range is high : from 123°F (50.5°C) to 140°F (60.0°C)	H . 140°F
When changing DHW setpoint, the DHW icon will flash	

\* Default DHW set-point is 120°F (49°C)

Changing between Celsius and Fahrenheit. When the button D is pressed (for more than 5 seconds), temperature unit will toggle between °C and °F.

#### • DHW 95-120°F (35 - 49°C) LOW range (Default)

-To change **LOW range**, press the C Button. The DHW icon and current DHW LOW will flash (a flashing value means it can be changed).

- Turn dial E clockwise to increase and counterclockwise to decrease until desired temperature is reached.
- Press dial E to save setpoint changes.

#### • DHW 121 - 140°F (49.5 - 60°C) HIGH range

-To change **HIGH range**, press and **HOLD** the C button for more than 5 seconds. The DHW icon and current DHW HIGH will flash (a flashing value means it can be changed).

- Turn dial E clockwise to increase and counterclockwise to decrease until desired temperature is reached.
- Press dial E to save setpoint changes and to Exit.

### DANGER

Scalding may occur within 5 seconds at a setting of 140°F (60°C). Water temperatures over 125°F can cause severe burns, or death from scalding. Children, disabled, and elderly are at highest risk of being scalded. Read all instructions before setting temperature at appliance. Feel water before bathing or showering.



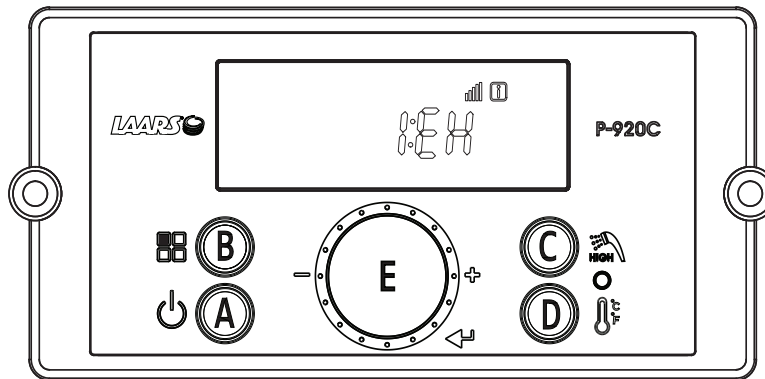

SECTION 5. Control Display and Operation

5.6 Installer Mode



These changes are to be made only by a qualified technician.

**To change any of the Installer Parameters,** Start by turning **OFF** the Power  to the Display Control.

Then, with the power OFF, Press and HOLD (5 seconds) the Button B  to get into the Installer Mode. Rotate Dial E until you find the Installer Parameter that you wish to change. Tap Dial E to enter that Parameter. Adjust to the setting that you require and then press (tap) Dial E to save and to Exit. Finish by pressing button B 

Index Numbers	Parameters	Description
1: EH	History entry	History fault code (E0~E9)
2: cE	Clear Error History	Clearing of error History buffer
3: In	System initialize	System initialize to default
4: Fu	Flow unit	L/m or GPM
5: FH	Max fan	Maximum fan parameter calibration
6: FL	Min fan	Minimum fan parameter calibration
7: dr	Reset Number of Ignition	Reset Number of Ignition
8: dl	Maximum fan	Adjust to maximum fan value(default: 0)
9: HA	High Altitude Settings	Choose from 0-2, 2-5, 5-8, and 8-10 (thousands) ft of altitude.



**SECTION 5. Control Display and Operation**

5.7 Error Mode

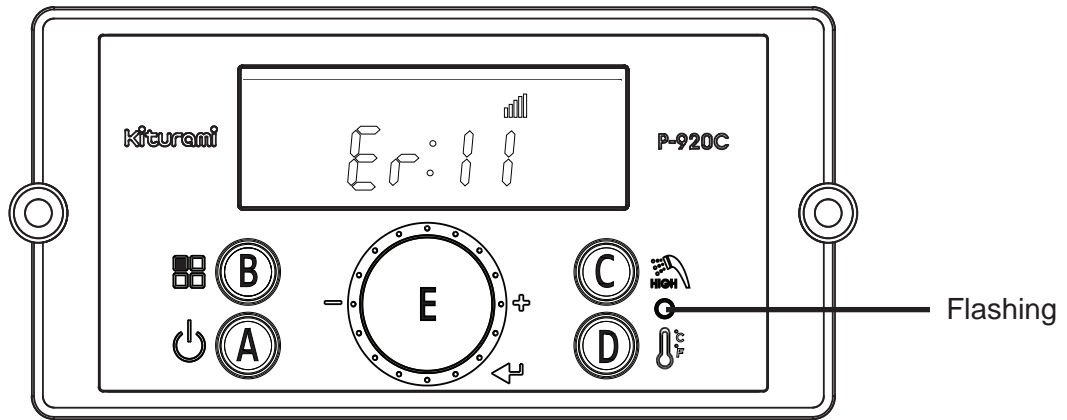

Indicate	Example
Error ' Er : ' will flash	Er:11
Error Code	Er:11
Display and Controller are communicating	

NOTE: When communication between the Control Display and the main controller is lost, the  will not be displayed.

**Section 6, Error Codes**

**6.1 Error Codes**

Error Code	Error Code Description	Possible Remedies	Recover methods
11	Ignition has Failed 10 (Ten) Times	Press the Power button to clear the Error Code. If Error happens again: 1. Monitor the gas pressure to the water heater while in operation. Ensure pressure is between 3.5 and 14" WC. 2. Check gas valve wire. Ensure connection is secure. 3. Check flame detection sensor. Ensure connections are secure. Normal operating settings are more than 2.5DC before ignition, less than 2.5DC after ignition. 4. Check igniter transformer for proper connection. 5. Clean the spark igniter with steel wool to remove oxides. Ensure proper separation (3-4 mm). 6. Replace the spark igniter if damaged. 7. Assure that the flame is stable when lit. 8. If the problem persists, replace the main control.	Hard Lock
16	Operating Temperature Sensor or DHW Sensor detects Water Temperature Greater than 199°F (93°C)	This Error Code will go away when the DHW temperature decreases. If Error happens again: 1. Check if dip switch MAX Fire setting is ON. Switches 6 and 7 should be OFF for normal operation. 2. Check if DHW pipe is blocked. Ensure there is enough water flowing to the water heater. 3. Check DHW sensor at DHW outlet. If resistance is zero, replace the sensor. 4. Check Operating Temperature sensor at the heat exchanger. If resistance is zero, replace the sensor. 5. If the problem persists, replace the main control.	Soft Lock
20	High Limit Overheat Switch – Closed is Normal, Open is Fault	Press the Power button to clear the Error Code. 1. Inspect the High Limit Overheat switch. Ensure proper connections. 2. Check High Limit Overheat switch resistance. If resistance is zero, replace the switch. 3. If the problem persists, replace the main control.	Hard Lock
29	APS/Condensate – Closed is Normal, Open is Fault (Condensate Drain Trap)	Press the Power button to clear the Error Code. 1. Check APS/Condensate and main controller connections. Ensure all are secure. 2. Check APS/Condensate resistance. If resistance is zero, replace the switch. 3. Check APS/Condensate hose. Ensure it is connected and in good condition. 4. Check condensate line and termination for blockages. 5. Check exhaust vent for blockages. 6. If the problem persists, replace the main control.	Hard Lock
31	Inlet Water Sensor Open or Short	This Error Code will go away when inlet water temperature decreases. If Error happens again: 1. Check inlet water temperature sensor. Ensure connections are secure. 2. Check sensor resistance. If resistance is zero, replace the sensor. 3. If the problem persists, replace the main control.	Soft Lock
32	DHW Sensor Open or Short	This Error Code will go away when outlet water temperature decreases. If Error happens again: 1. Check DHW outlet temperature sensor. Ensure connections are secure. 2. Check sensor resistance. If resistance is zero, replace the sensor. 3. If the problem persists, replace the main control.	Soft Lock

Error Code	Error Code Description	Possible Remedies	Recover methods
33	Operating Temperature Sensor Open or Short	This Error Code will go away when outlet water temperature decreases. If Error happens again: 1. Check operating temperature sensor. Ensure connections are secure. 2. Check sensor resistance. If resistance is zero, replace the sensor. 3. If the problem persists, replace the main control.	Soft Lock
35	Exhaust Sensor Open or Short	This Error Code will go away when exhaust temperature decreases. If Error happens again: 1. Check exhaust temperature sensor. Ensure connections are secure. 2. Check sensor resistance. If resistance is zero, replace the sensor. 3. Check exhaust vent for blockage. 4. If the problem persists, replace the main control.	Soft Lock
39	Flame Detected after Exiting a Flame On Condition	This Error Code will go away when the false flame condition is remedied. If Error happens again: 1. Check the water heater cover. Ensure it is secure. Flame detection sensor can detect an external light source. 2. Check flame detection sensor. Ensure connections are secure. Normal operating settings are more than 2.5DC before ignition, less than 2.5DC after ignition. 3. If the problem persists, replace the main control.	Soft Lock
40	Gas Leakage is Detected in 10 Minutes, or three times within One Hour (Greater than 5 Seconds Each Time)	IMPORTANT: If you smell gas, STOP! Follow the instructions on page 2, this manual, and call a qualified service technician or the fuel gas utility. Press the Power button to clear the Error Code. If Error happens again: 1. Check the water heater cover. Ensure it is secure. 2. Check gas connections for leakage with a soapy solution. Fix any leaks. 3. Check condition of the burner assembly. 4. If the problem persists, replace the main control.	Hard Lock
41	Fan Speed too High with Flame On	Press the Power button to clear the Error Code. If Error happens again: 1. Check the vent connections for blockages. 2. Check the burner assembly. 3. Check fan operation. If fan appears to be operating normally but RPMs are too low or too high, replace the fan. 4. If the problem persists, replace the main control.	Hard Lock
43	Burner Overheat Switch Open	Press the Power button to clear the Error Code. If Error happens again: 1. Check burner overheat switch connections. Ensure connections are secure. 2. Check switch resistance. If resistance is zero, replace the switch. 3. If the problem persists, replace the main control.	Hard Lock
61	Fan Speed Feedback Signal Abnormal	This Error Code will go away when the condition is remedied. If Error happens again: 1. Check the connections to the fan. Ensure all are secure. 2. If the fan does not rotate during the ignition sequence, check for 120V power at the fan connection. If 120V power is present at the control, replace the fan. If the blower does not have 120V power, check power at the control. If 120V power is not present at the control, replace the control. 3. If the problem persists, replace the main control.	Soft Lock

Error Code	Error Code Description	Possible Remedies	Recover methods
65	Supply Water Valve Error	Press the Power button to clear the Error Code. If Error happens again: 1. Turn power OFF and ON at the main power switch internal to the water heater. 2. Check wiring connections to supply water valve. Ensure all are secure. 3. Replace supply water valve. 4. If the problem persists, replace the main control.	Hard Lock
66	Mixing Valve Error	Press the Power button to clear the Error Code. If Error happens again: 1. Turn power OFF and ON at the main power switch internal to the water heater. 2. Check wiring connections to mixing valve. Ensure all are secure. 3. Replace mixing valve. 4. If the problem persists, replace the main control.	Hard Lock
67	AGM Error	Press the Power button to clear the Error Code. If Error happens again: 1. Turn power OFF and ON at the main power switch internal to the water heater. 2. Ensure fan inlet hole is completely open after turning the power OFF and ON. 3. Check wiring connections to the AGM. Ensure all are secure. 4. Check AGM operation. 5. Replace AGM components. 6. If the problem persists, replace the main control.	Hard Lock
72	Flame Signal Detected before Ignition	This Error Code will go away when the condition is remedied. If Error happens again: 1. Check the water heater cover. Ensure it is secure. Flame detection sensor can detect an external light source. 2. Check flame detection sensor. Ensure connections are secure. Normal operating settings are more than 2.5DC before ignition, less than 2.5DC after ignition. 3. If the problem persists, replace the main control.	Soft Lock
73	DIP Switch is abnormal	This Error Code will go away when the condition is remedied. If Error happens again: 1. Check dip switches. Ensure switches match the ratings plate requirements of the water heater. See dip switch details, this manual, for default settings. 2. If the problem persists, replace the main control.	Soft Lock
76	Poor Communication	This Error Code will go away when the condition is remedied. If Error happens again: 1. Check connections from main control to display panel. 2. If the problem persists, replace the display and/or the main control.	Soft Lock
94	Exhaust NTC detects Vent Temperature is Greater than 149°F (65oC)	This Error Code will go away when the condition is remedied. If Error happens again: 1. Check if dip switch MAX Fire setting is ON. Switches 6 and 7 should be OFF for normal operation. 2. Check exhaust temperature sensor. Ensure connections are secure. 3. Check sensor resistance. If resistance is zero, replace the sensor. 4. Check exhaust vent for blockage. 5. If the problem persists, replace the control. 6. If the problem persists, replace the heat exchanger.	Hard Lock

**Section 6, Error Codes**

6.2 Fault Tree Analysis

1. Flame Detection

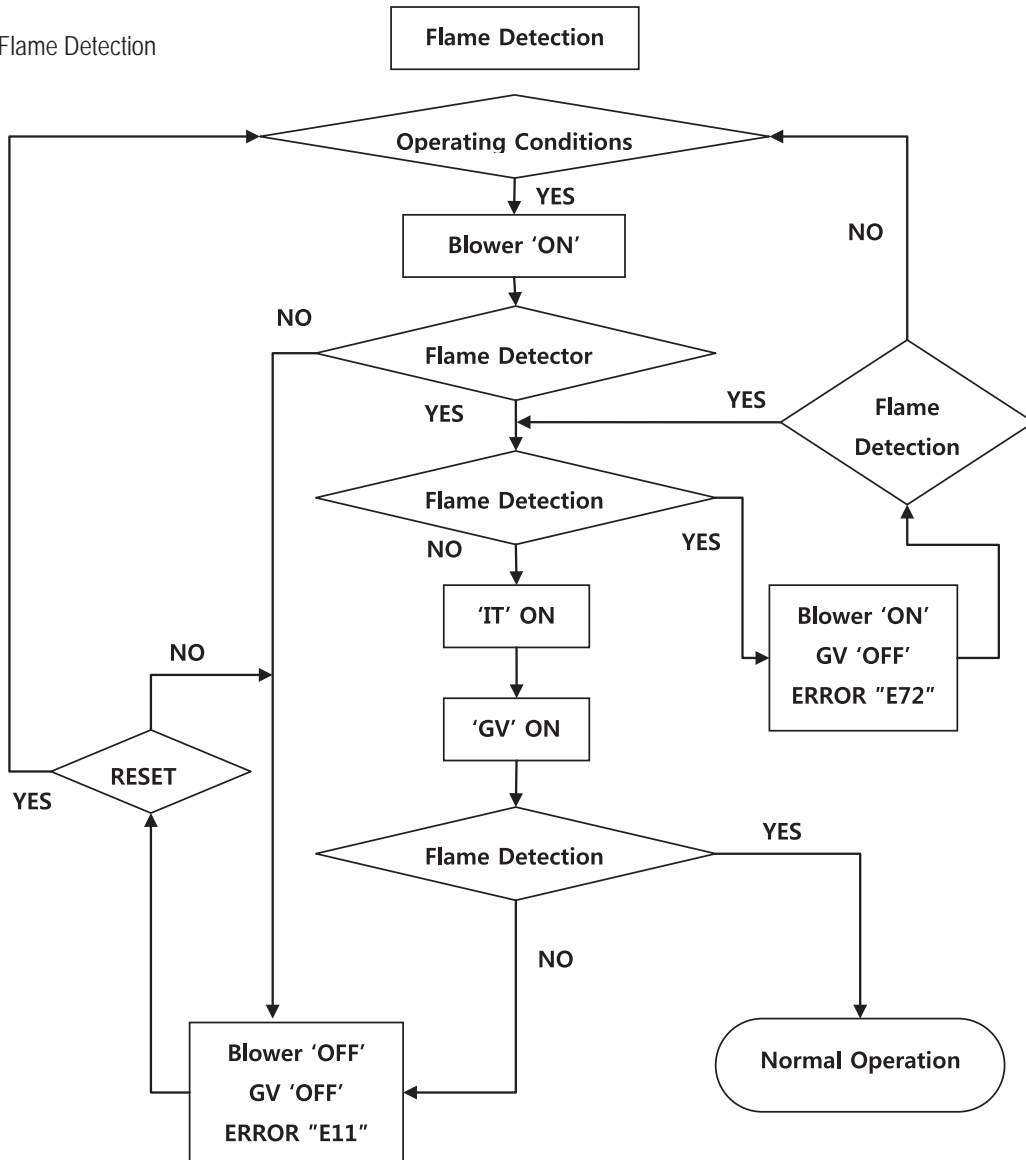

2. Gas Detection

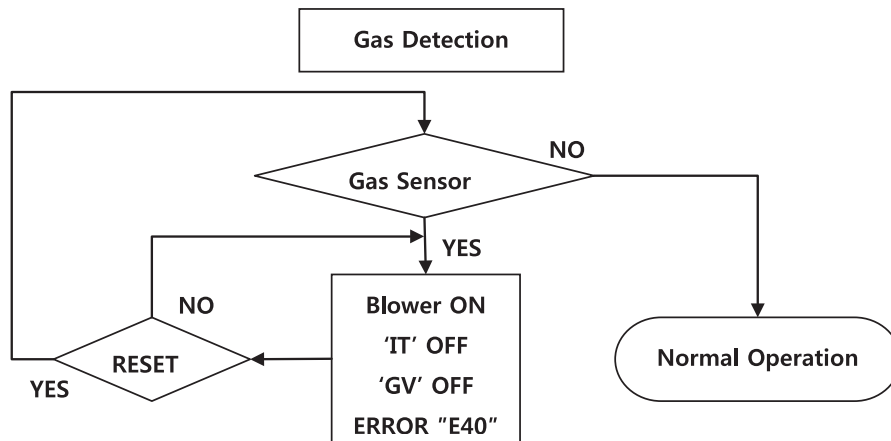

Section 6, Error Codes

6.2 Fault Tree Analysis

3. Fan / Air Proving

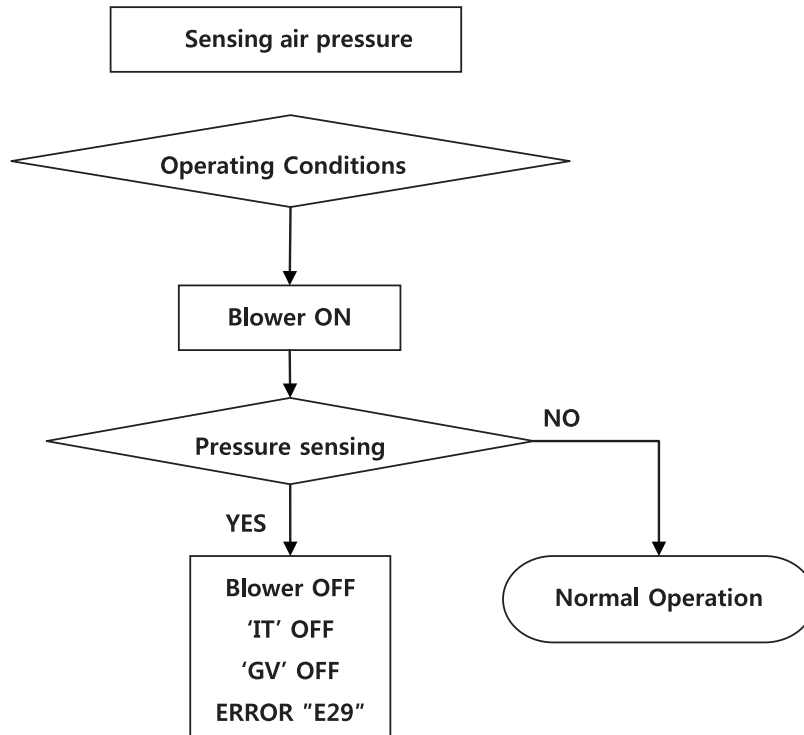

4. 'I/T', 'DHW', 'OP' Sensor detects

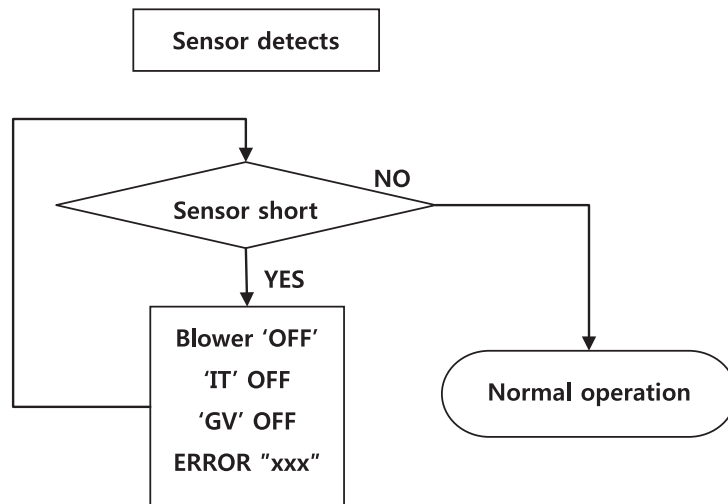

Error code	contents
E31	Inlet water NTC open or short
E32	DHW NTC open or short
E33	OP NTC open or short
E35	Exhaust NTC open or short



## Section 7 – Troubleshooting

## 7.1 Diagnostics

Before calling for service, review the following diagnostic steps first for saving time and money.

■ Question & Answer

Indicate	Indicator
Burner does not ignite even if hot water is opened.	Make sure that the ON/OFF button on the Control Panel has been turned ON.
	If the monitor on the Control Panel is blank, make sure the power cord is plugged and fuses on the main controller in the units are good.
	Make sure that there is water supplied to the unit. The heater will be running when the inlet water flow sensor detects the flow over 0.5gpm.
	Make sure the cold and hot water valve are not plumbed in reverse side.
	Make sure that cold water and gas supply lines are opened.
Outlet water is not hot enough.	Make sure that the setting temperature on the unit is not too low.
	Make sure that the filter in the cold water inlet line is not clogged with debris.
	Make sure that the gas supply type is correct.
	Check if the supply and manifold gas pressures are in accordance with specifications.
	Make sure that the water flow sensor with three wires has been properly connected on the top of heat exchanger.
Outlet water is too hot.	Make sure that the setting temperature on the unit is not too hot.
	Make sure that the filter in the cold water inlet line is not clogged with debris.
	Make sure that the gas supply type is correct.(Check the provided gas with the water heater model)
Hot water temperature	Make sure that the filter in the cold water inlet line is clean.
	Check if the supply gas pressure is sufficient.
The blower is still operating after the combustion stops.	This is normal because the blower still keeps operating for 3 minutes. If a BLDC motor is not running in 120VAC, replace the BLDC motor.
Abnormal sounds come from unit during operation.	A leak of combustion gas between sealed chamber and exhaust duct inside the unit. Immediately call a qualified service technician for evaluation.
	Improper venting termination, make sure that the venting termination complies with specification.
	Check if the supply gas pressure is sufficient. Insufficient gas pressure will cause unstable burner flame and noise.

Section 7 – Troubleshooting

7.1 Diagnostics

■ Diagnostics and suggested corrective actions

This controller is able to record information about the water heater's condition for the ten previous faults or errors. Refer to the 'Error Code' section of this Manual, (Section 6).

Display	Condition	Diagnostic	Corrective Action(s)
Nothing shown on display control panel and blower running at full speed.	Panel is not receiving power.	Check wiring for short circuit or incorrect wiring.	Correct wiring per wiring diagram including connection of transformer to the control.
		Check for 14V output of panel wire.	Push the 'A' button of control panel.
Nothing is shown in display control panel and no other Water Heater components are operating.	Control is not receiving 120V power.	Is there 120 Volts at the manual switch?	Correct the power supply from the manual switch.
		Check the water heater inside power manual switch.	Turn on the manual power switch inside the water heater case.
		Check for 120 volts at the line voltage terminal inside the water heater case.	Correct wiring inside the water heater case using the wiring diagram in this manual.
Nothing is shown on control panel, but water heater is operating.	Occurs when the communication is lost from the control to the display.	Check for loose connections and proper pin alignment/ engagement on the Control's plug.	Check for continuity on the wire harness from the display to the control panel. See repair parts section for proper replacement part.
		Cycle power off and on using water heater power switch and check for operation.	Replace with new display module. See repair parts section for proper replacement part.
TEMPERATURE RISE TOO QUICKLY	Occurs when supply water temperature in heat exchanger rises faster than 2°F per second during the first two minutes the burner is on.	Automatically resets after a few minutes delay or use manual reset.	See the message displayed TEMPERATURE SENSOR and follow procedures for loose connections.
TEMPERATURE SENSOR	Occurs when a temperature sensor has electrically shorted(SHORT) or has become disconnected (OPEN).	Reset using manual. Reset screen on control panel. (Power button)	Check all the temperature readings of the water heater on the DIAGNOSTICS - TEMPERATURES menu to determine if any sensors are currently displayed as SHORT or OPEN.
			Check wire harness for loose connections and pin engagement at sensor Connection and Control module.
			If problem persists after checking items above, replace Control. Refer to the installation manual 32-36page.

## Section 7 – Troubleshooting

## 7.1 Diagnostics

Display	Condition	Diagnostic	Corrective Action(s)
FLAME FAULT	Occurs when flame is detected when there should be no flame	Reset using manual switch. Reset screen on control panel. (Power button)	Burner may be operating too hot due to incorrect combustion.
			Check for flame at burner via flame current with burner off. Turn off and watch flame through observation port. If flame continues after shutdown, replace gas valve.
BLDC Fan FAULT	BLDC Fan is unable to reach required speed or 0 RPM when it is turned off.	Reset using manual switch. Reset screen on control panel. (Power button)	Check wire harness for loose connections and pin engagement at blower connections.
			Water heater is in standby mode and fan is not running. If FAN SPEED is not 0 RPM then replace the fan.
IGNITION FAULT	Even if water heater went through 8 ignition attempts, but cannot detect flame.	Manual switch Power off and on.	Visual inspection of flue ways often will not be able to diagnose condition.
			Check incoming gas pressure with water heater off and at MAX fire. Adjust within limits on rating plate.
			Check for vent pipe and intake pipe restrictions or blockage
			Check burner fasteners and gaskets
			Check air intake pipe and orifice
GAS VALVE FAULT	The Control has detected a problem with its gas valve output circuit	Reset using manual switch. Reset screen on control panel. (Power button)	Check wire harness connections between gas valve and Control.
			If lockout reoccurs, replace Gas valve.

**Section 8 – Maintenance**

**Regular Maintenance**

After Water Heater installation is completed, this manual should be placed in safe dry location near the water heater. Maintenance instructions should be carried out by these guidelines annually by a qualified technician.

Maintenance details, please refer to the instructions below.

Periodically	Please check installation location. Please check if water heater casing is closed. Please check power source.
Monthly	Please check vent pipe. Please check air inlet pipe. Please check relief valve. Please check condensate outlet.
Every 6 Months	Please check water heater piping (gas and water) Please check operate relief valve
No plan for long-term use.	Do not shut Water Heater down.

**Maintenance procedures [ Periodically ]**

- Check installation location  
To prevent potential severe personal injury, death or substantial property damage, remove all contaminated materials.  
If contaminants are found :  
Remove products immediately from the area.  
In order to check the status of Water Heater, call a qualified service technician to inspect the Water Heater for possible damage from acid corrosion.
- Check if WATER HEATER casing is closed.  
Check if there is any problem with the Water Heater casing and the two upper and lower screws are tightened well. Water Heater casing must be closed while it is running.



DO NOT store combustible materials, gasoline or any other flammable vapors or liquids near the Water Heater. Remove them immediately or store them other places.

**8.1 Annual Startup and General Maintenance**

**Maintenance procedures [ Periodically ]**

- Check power source.  
Make sure that the power cord is correctly connected. The main power line is connected to the manual switch box inside the Water Heater.
- Check status of the control panel.  
Check status of the power supply. Please check for any debris on the button.

**Maintenance procedures [Monthly]**

- Check vent pipe.  
Visually inspect the flue gas vent piping for detecting any signs of blockage, leakage or deterioration of the piping. Please contact a qualified service technician immediately if you find any problem.
- Check air inlet pipe.  
Visually inspect the air inlet to be sure it is unobstructed. Inspect entire length of air piping for ensuring that piping is intact and all joints are properly sealed. Call your qualified service technician if you notice any problems.
- Check relief valve.  
Inspect the Water Heater relief valve and the relief valve discharge pipe for any signs of weeping or leakage. If the relief valve often weeps, immediately contact your qualified service technician for inspecting the Water Heater and system.
- Check the condensate outlet.  
While the Water Heater is running, check the discharge end of the condensate drain tubing. Make sure that no flue gas is escaping from the condensate drain tubing.  
If flue gas is continuously escaping, it is a serious problem. Call your qualified service technician for inspecting the Water Heater and condensate line. Also, refill the condensate trap if problem persists regularly.

- Visually inspect the vent terminal rodent screen.  
If clogged with debris, clean the screens or replace it with spare parts.



**Section 8 – Maintenance****8.1 Annual Startup and General Maintenance****- Cleaning Air Intake Filter**

- To properly maintain the water heater, you should clean the air intake filter every 3 months. If not, you may encounter combustion issues

To clean air intake filter:

1. Press Power button on the control panel to turn off the water heater.
2. Disconnect power supply to water heater.
3. Remove front cover of water heater.
4. Pull the filter out of air intake adapter.

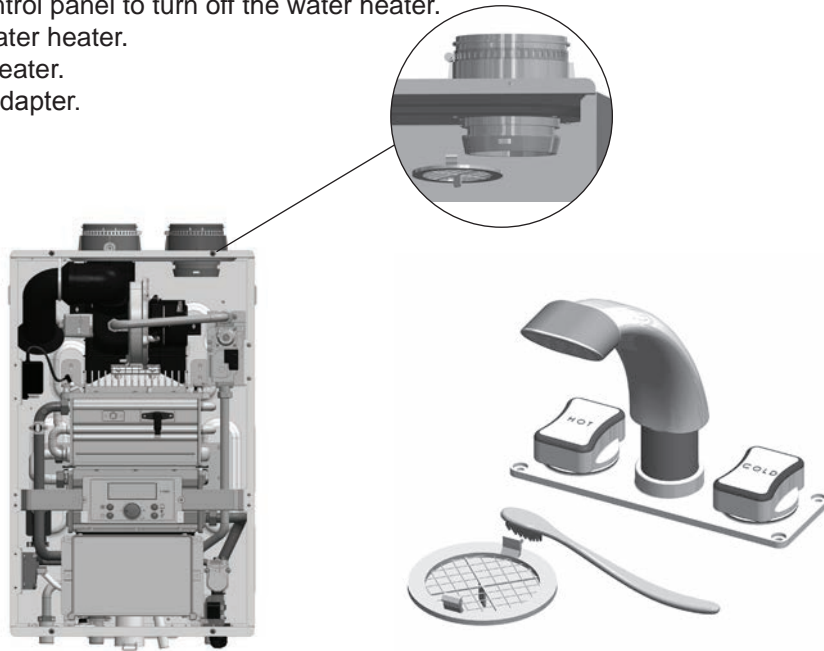

5. Remove the filter from the plastic assembly and clean it with a toothbrush and clean running water.
6. Dry the filter completely. And then reinsert the filter into the plastic assembly.
7. Replace the front cover. And then reconnect the power supply to the water heater.
8. Press Power button on the front panel to turn on water heater.

**- Cleaning cold water Inlet Filter (Draining the Water Heater)**

1. Place a bucket under the appliance to collect the residual water inside the water heater.
2. Press Power button on the front control panel to turn off the electrical power to the water heater. And then turn off the gas valve.
3. Close water supply valve on the inlet to the appliance. If there is no valve, turn off main water valve.
4. Please open the hot water faucets completely.
5. Remove the cold water inlet filter. And then clean it with a toothbrush and clean running water.



6. To refill the water heater, follow the steps of "Draining the Water Heater" in reverse.

**Section 8 – Maintenance**

- Flushing the Water Heater

Flushing the Heat Exchanger of water heater is a complicated procedure and should only be done by an authorized technician or licensed professional. Keep in mind that improper maintenance can void your warranty.

1. Disconnect electric power to the water heater.
2. Close the shutoff valves on both hot water outlet and cold water inlet lines. (V1 & V2)
3. Connect one hose “D1” to the valve “V3” and place the free end in the bucket. Connect one of the hoses “D3” to the circulation pump outlet and the cold water inlet line at the valve “V4”. Connect other hose “D2” to the circulation pump inlet and place the free end in the bucket.

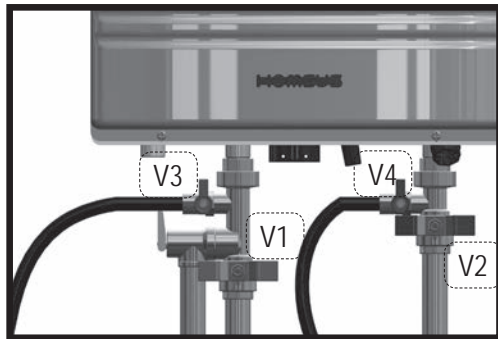

4. Pour the cleaning solution into the bucket. Place the drain hose (D1) and the hose (D2) to the pump inlet into the cleaning solution.
5. Open service valves (V3 & V4) on the hot water outlet and cold water inlet lines.
6. Turn on the circulation pump (Operate the pump and allow the cleaning solution to circulate through the water heater for at least 1 hour at a rate of 4 gallons per minute.)
7. Rinse the cleaning solution from the water heater as follows:
  - Remove the free end of the drain hose (D1) from the bucket.
  - Close service valve, (V4), and open shutoff valve, (V2). Do not open shutoff valve, (V1).
  - Allow water to flow through the water heater for 5 minutes.
  - Close shutoff valve (V2).

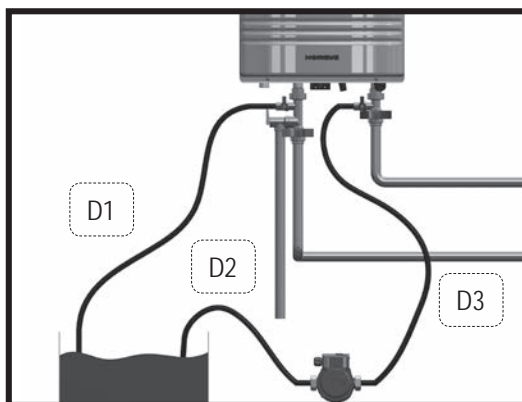

**8.1 Annual Startup and General Maintenance**

8. Disconnect all hoses.
9. Remove the cold water inlet filter from the water heater and clean out any residues.
10. Reinsert the filter and ensure the filter cap is securely tightened.
11. Connect electrical power to the water heater.

■ **Maintenance procedures [Every 6 Months]**

- Check piping. (gas and water)

Visually inspect for leaks around internal water piping. Also inspect external water piping, circulators, relief valve and fittings. Immediately call a qualified service technician to repair any leaks.

Leaks must be fixed by a qualified service technician immediately. Failure to comply with this instruction could result in severe personal injury, death or substantial property damage.

- Check relief valve operation

**WARNING**

Leaks must be fixed by a qualified service technician immediately. Failure to comply with this instruction could result in severe personal injury, death or substantial property damage. This discharge line must be installed by a qualified heating installer or a service technician.

**WARNING**

Before proceeding with maintenance, verify that the relief valve has been piped to a safe place, avoiding any possibility of scalding from hot water.

Before proceeding the procedures, verify that relief valve outlet has been piped to a safe place of discharge, avoiding any possibility of scalding from hot water.

If water flows freely, release the lever and allow the valve to seat. Watch the end of the relief valve discharge pipe to ensure that the valve does not weep after the line has had time to drain. If the valve weeps, lift the seat again to attempt to clean the valve seat. If the valve continues to weep, contact your qualified service technician for inspecting the valve and system. If water does not flow from the valve even though you have lifted the lever completely, the valve or discharge line may be blocked. Shut down the Water Heater immediately. Call your qualified service technician to inspect the water heater and system.

- Check burner condition

The burner should be cleaned or replaced by a qualified service technician when needed.



## Section 9 – Installation Check

### 9.1 Quick View

- **Before Installing**
  - Make sure that there is enough space for installing Water and gas line.  
Verify vent/air termination is located as required.
  - All models need for propane Conversion which requires a separate gas conversion manual.
- **Install Water Piping**
  - Water Heater loop piping must be sized to the minimums listed in the Water Heater manual. Using smaller piping will cause performance problems. (Page 32)
- **Install Vent & Air Piping**
  - Slide the air inlet pipe and vent pipe into the Water Heater pipe connector.
  - Make sure the terminations are placed as required in the manual and that air intakes are at least 12 inches above normal snow line.
  - Refer to the material check list in this guide for a list of items needed.
- **Install Condensate Piping / Tubing & Components**
  - Fill out the material check list in this guide to ensure you have the tubing or PVC pipe and all components needed for the condensate piping.
  - Connect internal components that are supplied with the Water Heater.
- **Install Gas Piping**
  - Install a union and shutoff valve.
- **Wire the Water Heater**
  - Connect power wiring and control wiring per water heater manual wiring diagram.(Section 5.17)
- **Start up, Adjust & Test**
  - Follow the Water Heater manual instructions to clean the system if needed, then fill and check water chemistry.

### 9.2 Final check lists

- **Final check : Installation Conditions.**
  - Is the Water Heater properly mounted on the wall?
  - Is there space for a drain which is close to the Water Heater?
  - Are there any combustible materials near the Water Heater and vent pipe?
  - Is the air supply sufficient for proper operation of the Water Heater?
  - Are the proper service clearances maintained?
  - Is the distance between the Water Heater and point of vent termination minimized?
  - Is the proper distance from windows, doors, and other intake vents maintained?
- **Final check : Gas pipe installation**
  - Is the gas supply line equipped with a manual shut off valve?
  - Is the gas supply line a minimum of 3/4" inner diameter?
  - Is the gas supply line length and diameter adequacy to deliver the required BTU's?
  - Has the gas supply line pressure been measured?
  - Does the supply gas type match the type indicated on the water heater rating plate?
- **Final check: Air/Vent pipe installation**
  - Has the Water Heater been vented with 3" or 2" PVC, CPVC, Polypropylene or BH Special Gas Vent (S636 PVC, CPVC) for Category IV appliances in accordance with this manual and/or your local code?
  - Is the vent termination at least 12" above the exterior grade?
  - Is the total vent length within the maximum vent length restriction?
  - Have you checked the air/vent piping for leaks?
  - Have you properly supported the vent termination?
  - Are all vent runs properly supported?
  - Is the vent sloped upward toward the vent termination at a rate of 1/4" per foot (2% grade)?
- **Final check : Condensate drain installation**
  - Have you installed a condensate drain line from the Water Heater to a drain or laundry tub?
- **Final check : Setting the DIP switches**
  - Are all DIP switches correctly set on the main board?



- Final check : Connecting the power supply
  - Please check that the power is 120V AC.
  - Have you checked the polarity of the electrical connection?
  
- Final check : Pressure relief valve
  - Have you installed an approved pressure relief valve on the water heater?
  - Is the pressure relief valve of DHW Plumbing at least 3/4" in diameter?
  - Have you installed the pressure relief valve on the hot water outlet pipe near the Water Heater?
  
- Final check : Burner flames
  - The burner flame must be checked periodically for a constant proper blue color.
  - If the flame does not appear normal, the burner may need to be cleaned.
  - If the burner needs to be cleaned, it must be performed by a qualified service technician.

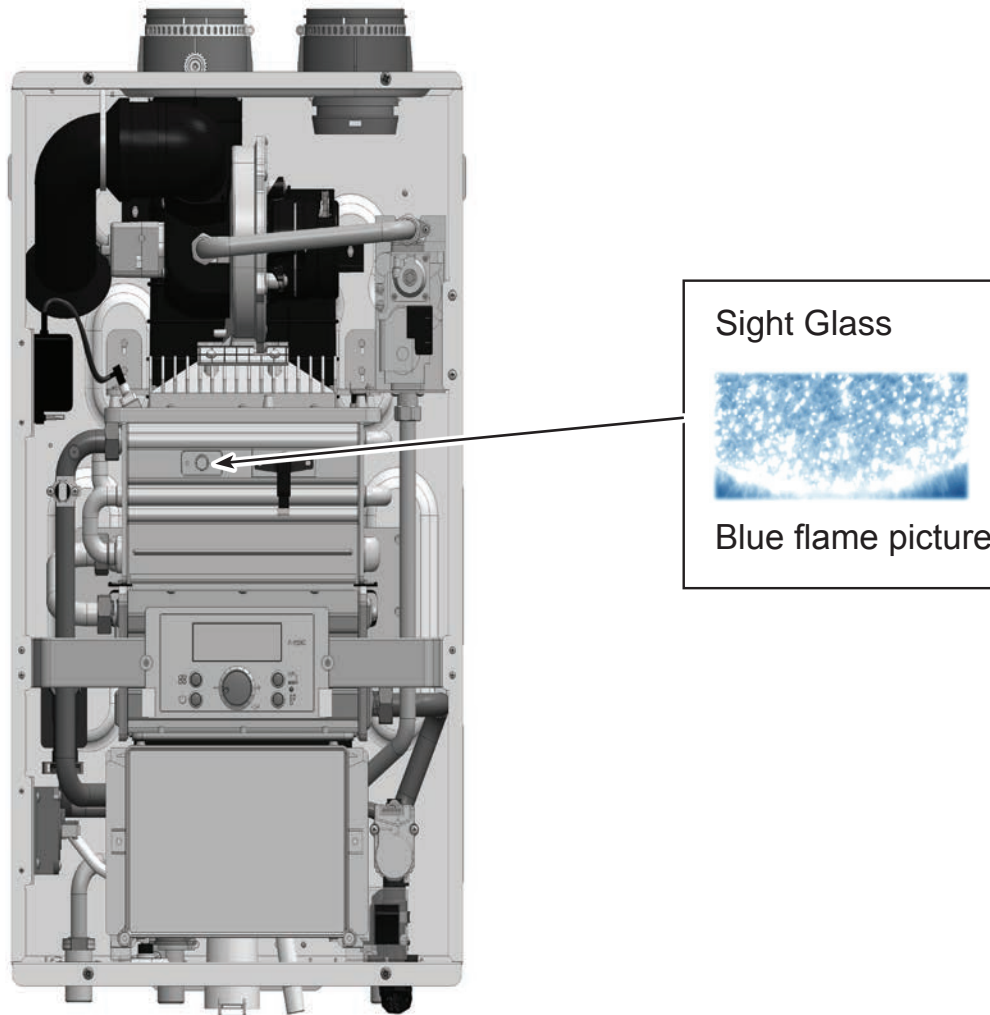

**Section 10** – Repair Part Diagram

## 10.1 Parts List

## Part list

IOM Ref	Laars #	Description
1	ST1001	Exhaust ASS'Y
2	ST1002	Case
3	ST1003	Cover Assembly
3-1	ST1003	Front Cover
3-2	ST1004	MMI Panel Bracket
3-3	ST1005	MMI Panel
4	ST1006	Ignition Transformer
5	ST1007	Gas Inlet Nipple
6	ST1008	Overheat Sensor
7	ST1009	DHW Supply Pipe ASS'Y
7-1	ST1010	DHW Supply Pipe
7-2	ST1011	Water Outlet Sensor
8	ST1012	Siphon ASS'Y
9	ST1013	Siphon Air Pressure Hose
10	ST1014	Air Pressure Switch
11	ST1015	MMI Bracket
12	ST1016	MMI
13	ST1017	PCB
14	ST1018	PCB Bracket
15	ST1019	Manual Switch
16	ST1020	Flow Control Valve
17	ST1021	Water Inlet Pipe ASS'Y
17-1	ST1022	Water Inlet Pipe
17-2	ST1023	Water Inlet Sensor
17-3	ST1024	Water Inlet Filter
17-4	ST1025	Water Inlet Filter Cap
18	ST1026	Case Bracket (Left)
19	ST1027	Case Bracket (Right)
20	ST1028	Intake Air ASS'Y

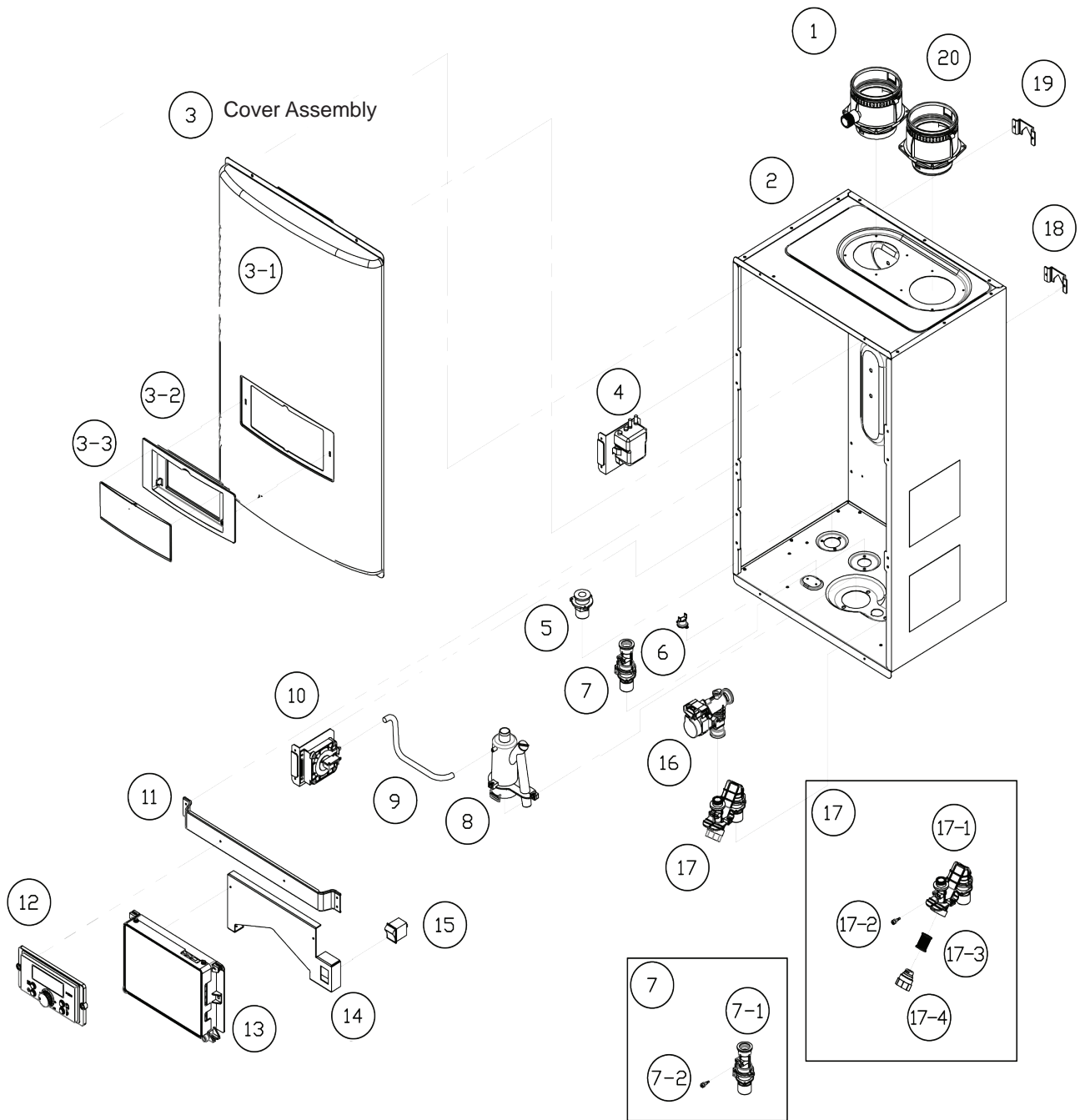

Part list

31	ST1029	Heat Exchanger Assembly
31-1	ST1030	Exhaust Pipe Assembly(UP)
31-2	ST1031	Exhaust Temperature Sensor
31-3	ST1032	Exhaust Packing 1
31-4	ST1033	Exhaust Pipe Assembly(DOWN)
31-5	ST1034	Exhaust Packing 2
31-6	ST1035	Condensate Gutter
32	ST1036	Blower Assembly
32-1	ST1037	Blower
32-2	ST1038	O-Ring
32-3	ST1039	AGM(Actuator)
33	ST1040	Silencer Elbow
34	ST1041	Silencer Body
35	ST1042	Burner Assembly
35-1	ST1043	Burner Head
35-2	ST1044	Ignition Rod Bracket
35-3	ST1045	Ignition Rod
35-4	ST1046	Burner Fixing Bracket
35-5	ST1047	Overheat Sensor(Burner)
35-6	ST1048	Metal Fiber

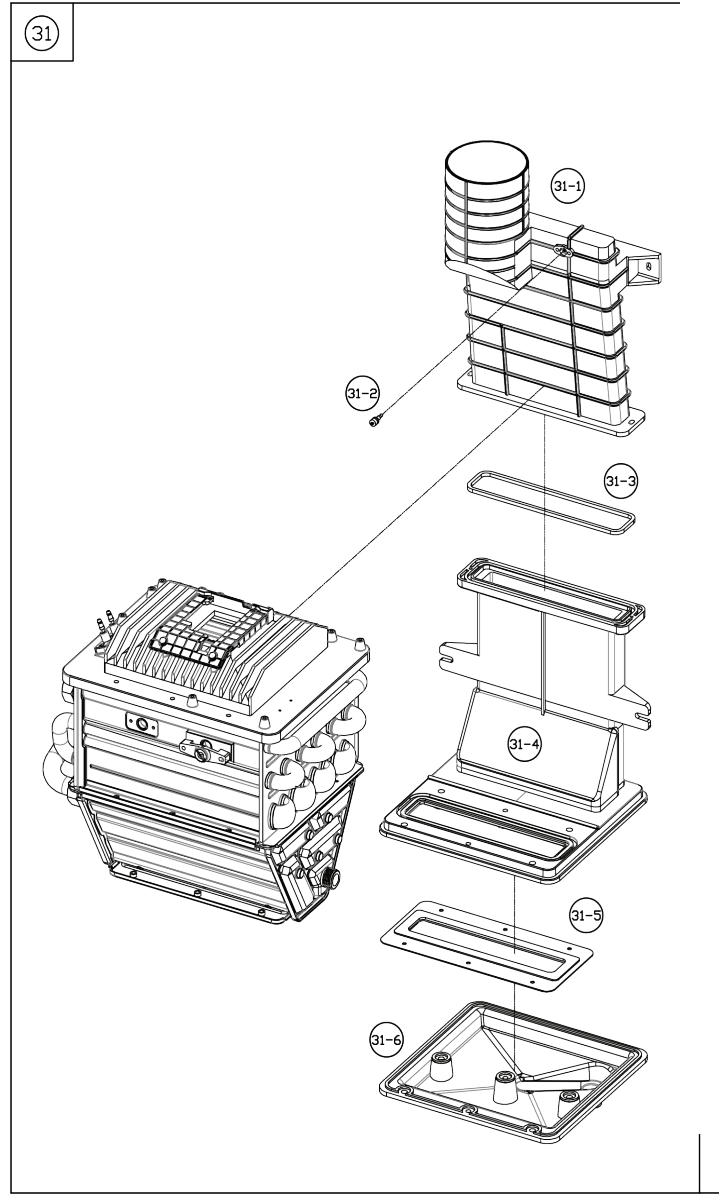
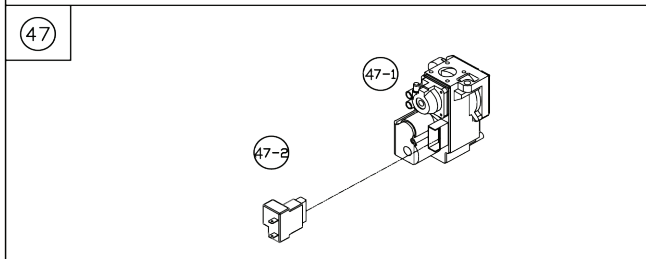
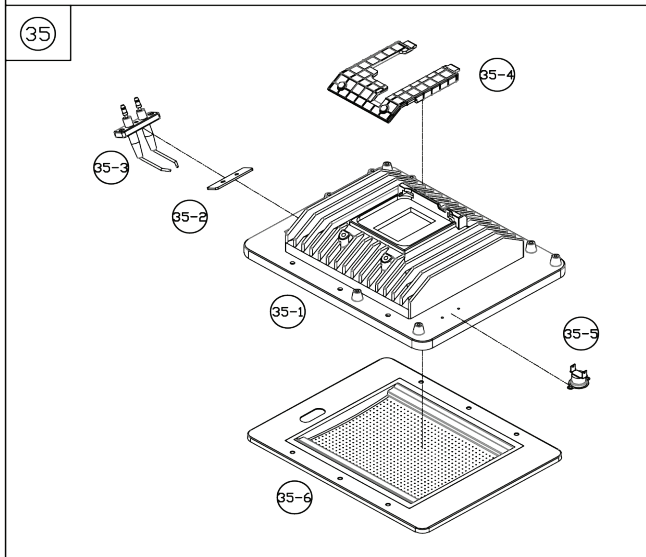
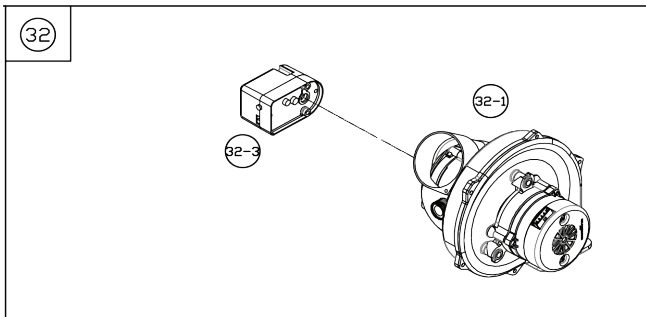

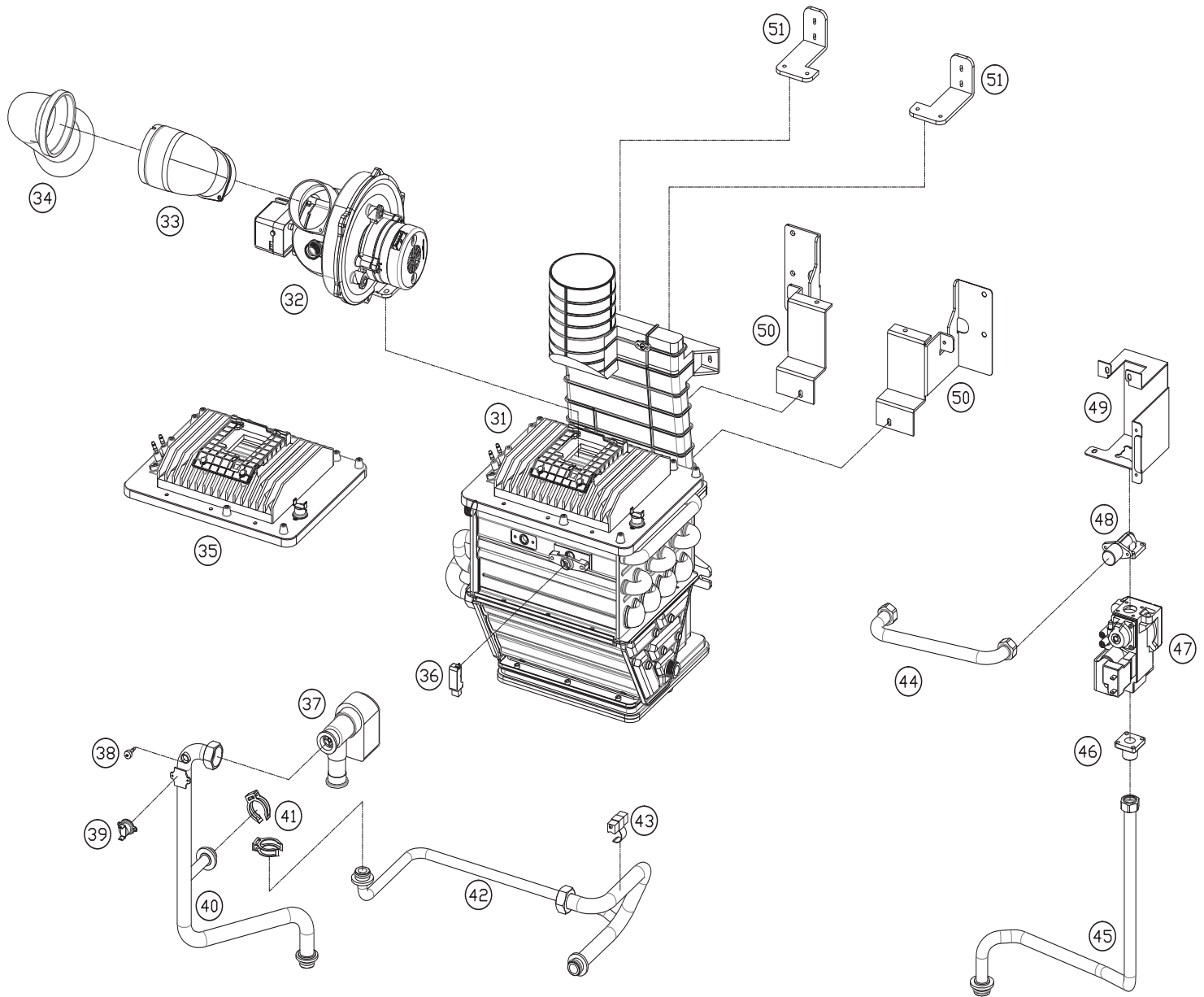

Part list

36	ST1049	Flame Detector
37	ST1050	Mixing Valve
38	ST1051	Heat Exchanger Temperature Sensor
39	ST1052	Overheat Sensor(Heat Exchanger)
40	ST1053	DHW Outlet Pipe
41	ST1054	Water Hammer Clip
42	ST1055	DHW Inlet Pipe
43	ST1056	Ceramic Heater
44	ST1057	Gas Inlet Pipe
45	ST1058	Gas Supply Pipe (to gas valve)
46	FT1538	Gas Valve Adapter (inlet)
47	ST1060	Gas Valve Assembly
47-1	ST1061	Gas Valve
47-2	ST1062	Gas Valve Plug
48	FT1728	Gas Valve Adapter(outlet)
49	ST1064	Gas Valve Bracket
50	ST1065	Case Bracket (Heat Exchanger) Left
	ST1066	Case Bracket (Heat Exchanger) Right
51	ST1067	Case Bracket (Burner)







