



Trinity Lx High Efficiency Gas Condensing Water Heater

Application Guide

Section 1 – Plumbing Schematics
Section 2 – Electrical

1 PLUMBING SCHEMATICS

Single Water Heater, Single Tank

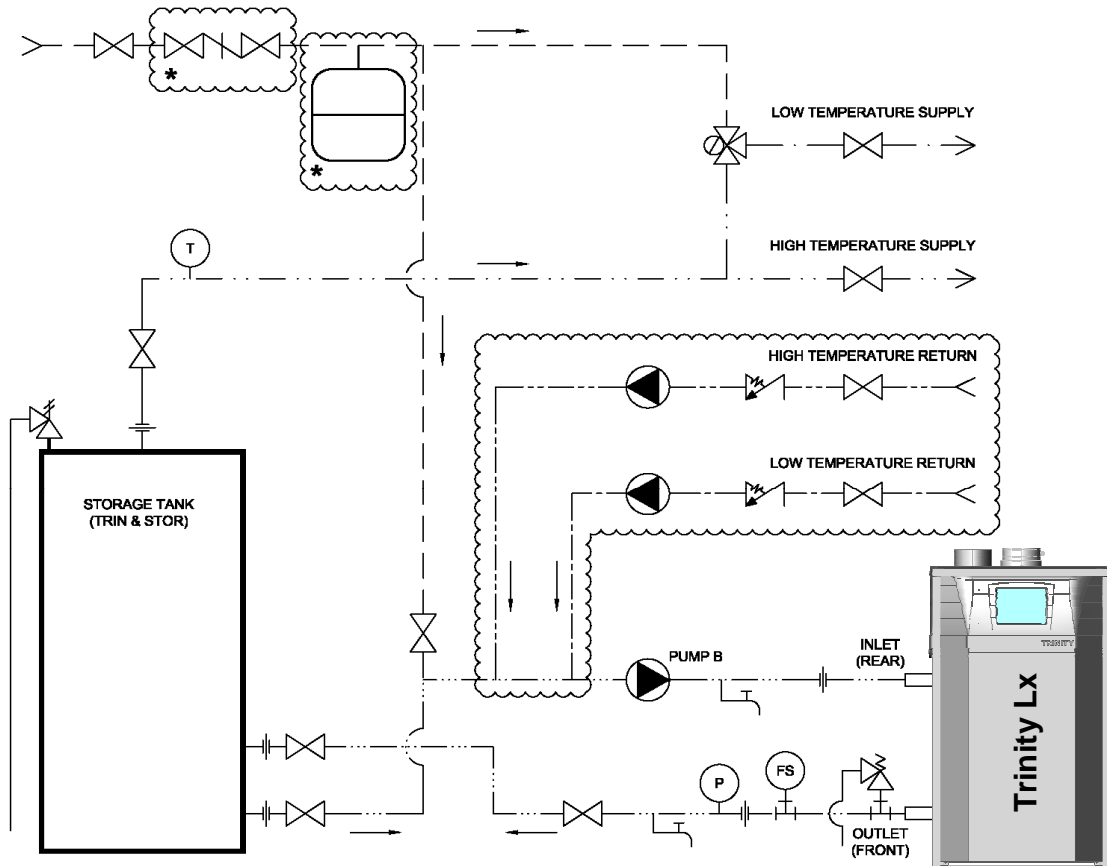

LEGEND

SYMBOL	DESCRIPTION	SYMBOL	DESCRIPTION	SYMBOL	DESCRIPTION
---	DOMESTIC COLD WATER		PRESSURE RELIEF VALVE		FLOW SWITCH
---	DHWH LOW TEMPERATURE SUPPLY		THERMOSTATIC MIXING VALVE		SPRING CHECK VALVE
---	DHWH LOW TEMPERATURE RETURN		TEMPERATURE AND PRESSURE RELIEF VALVE		PUMP
---	DHWH HIGH TEMPERATURE SUPPLY		DRAIN VALVE		UNION
---	DHWH HIGH TEMPERATURE RETURN		TEMPERATURE GAUGE		TEE
---	WATER HEATER LOOP		EXPANSION TANK		FLOW DIRECTION
	ISOLATION VALVE		OPTIONAL		CHECK LOCAL CODES
	BACKFLOW PREVENTOR		PRESSURE GAUGE		



Trinity Lx High Efficiency Gas Condensing Water Heater

Application Guide

1 PLUMBING SCHEMATICS

Multiple Water Heaters, Single Tank

LEGEND			
SYMBOL	DESCRIPTION	SYMBOL	DESCRIPTION
---	DOMESTIC COLD WATER	⊖	FLOW SWITCH
---	DHW LOW TEMPERATURE SUPPLY	⊕	PRESSURE RELIEF VALVE
---	DHW LOW TEMPERATURE RETURN	⊕	THERMOSTATIC MIXING VALVE
---	DHW HIGH TEMPERATURE SUPPLY	⊕	TEMP AND PRESSURE RELIEF VALVE
---	DHW HIGH TEMPERATURE RETURN	⊕	DRAIN VALVE
---	WATER HEATER LOOP	⊕	TEMPERATURE GAUGE
---	ISOLATION VALVE	⊕	EXPANSION TANK
---	BACKFLOW PREVENTOR	⊕	OPTIONAL
---		⊕	PRESSURE GAUGE
---		⊕	SYSTEM SENSOR

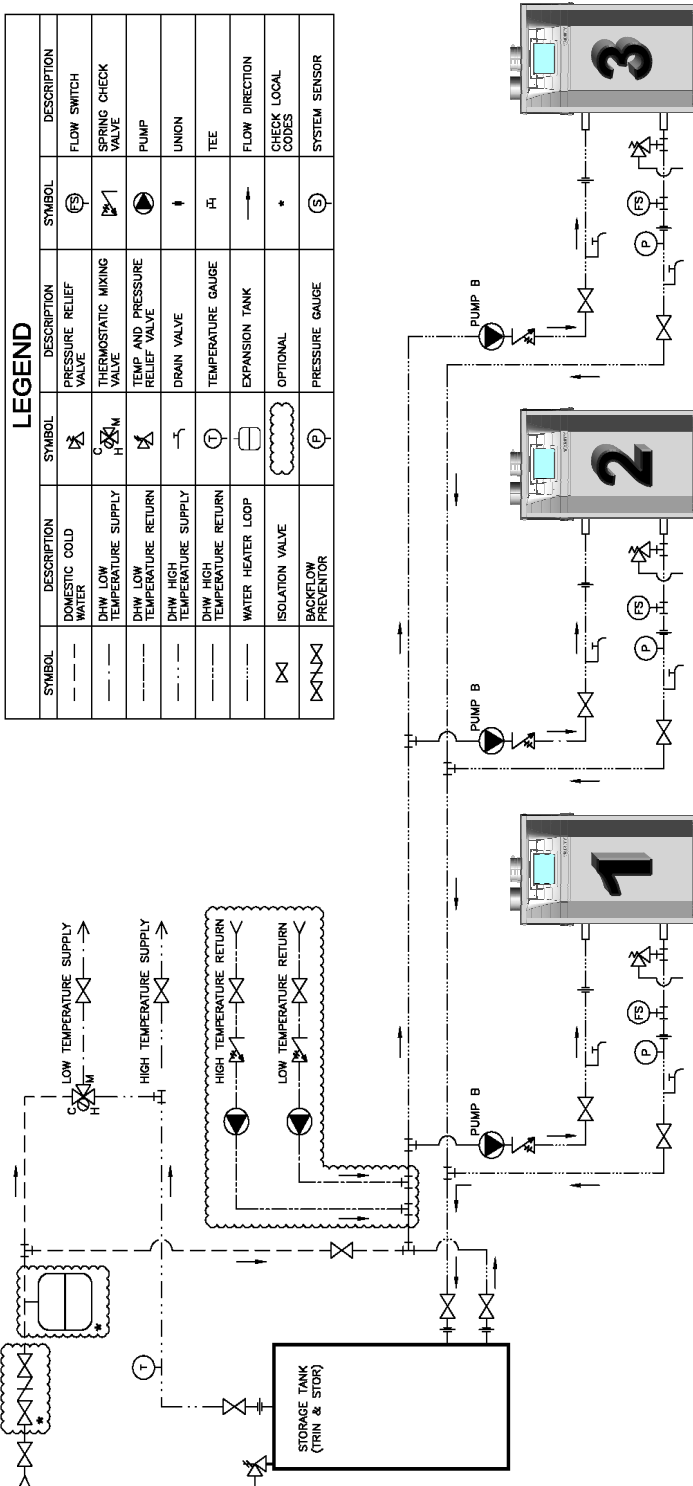

Trinity Lx

Trinity Lx

Trinity Lx

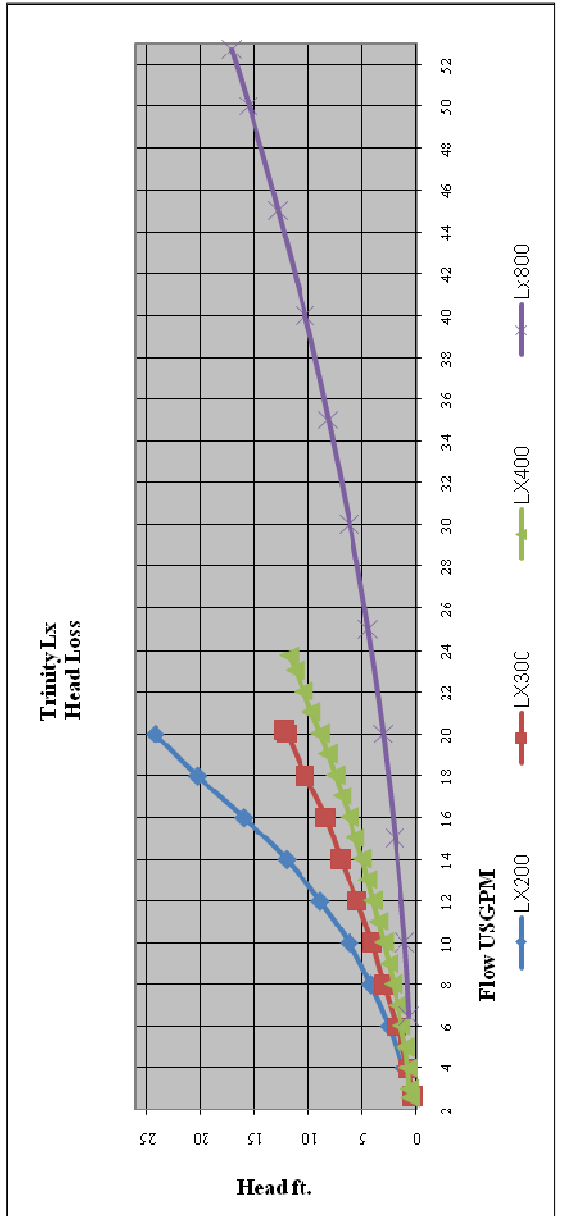



Trinity Lx High Efficiency Gas Condensing Water Heater

Application Guide

1 PLUMBING SCHEMATICS

Multiple Water Heaters, Multiple Tanks

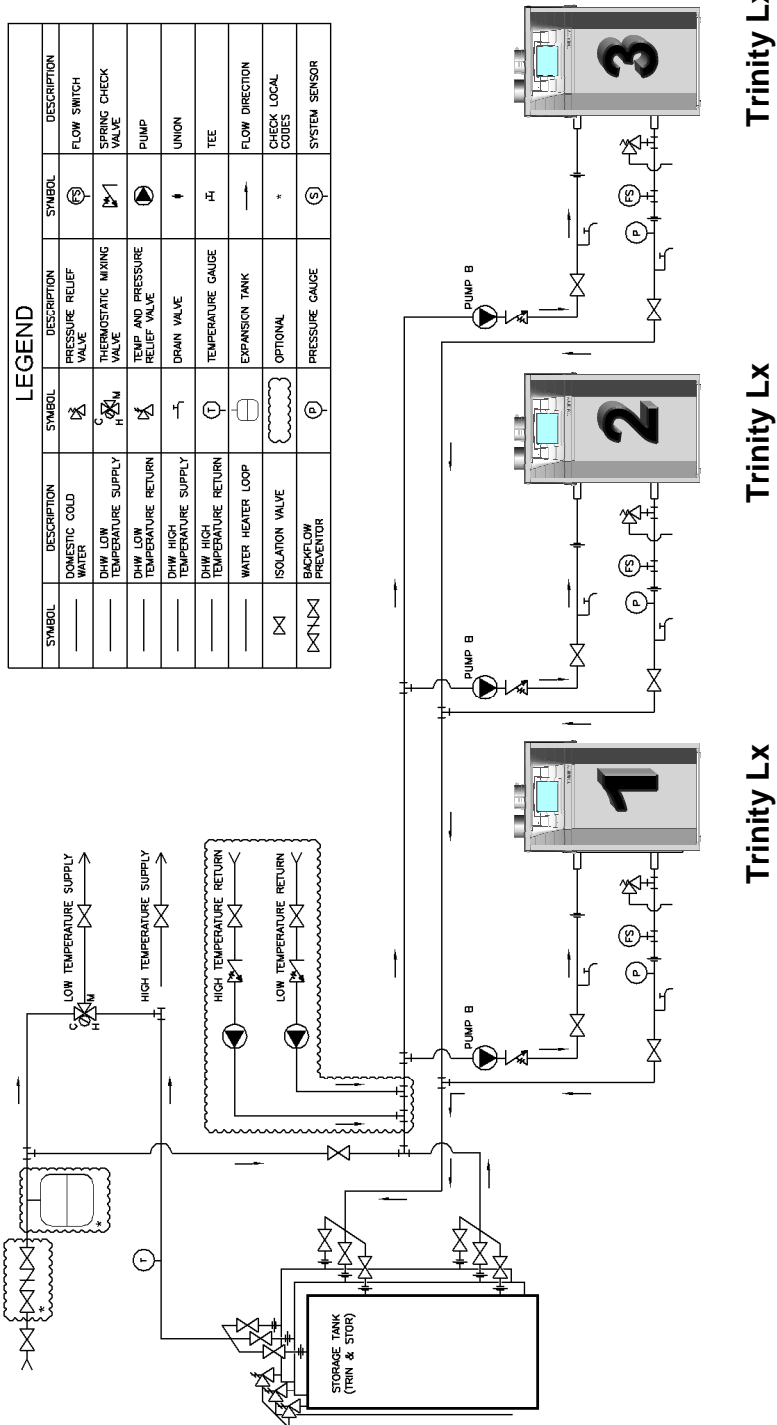



Trinity Lx High Efficiency Gas Condensing Water Heater

Application Guide

2 ELECTRICAL

Single Water Heater Wiring Diagrams

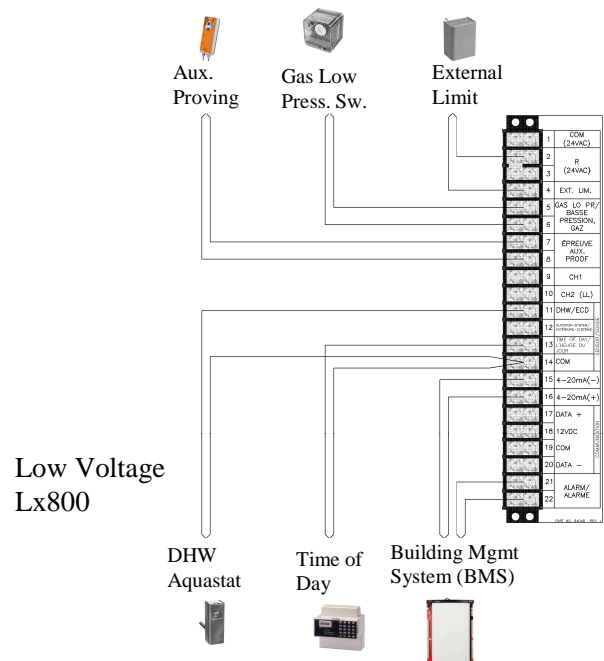
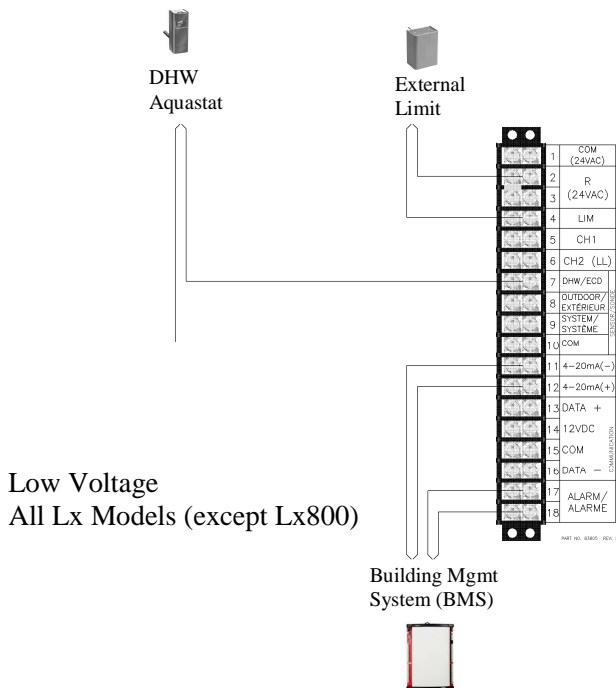
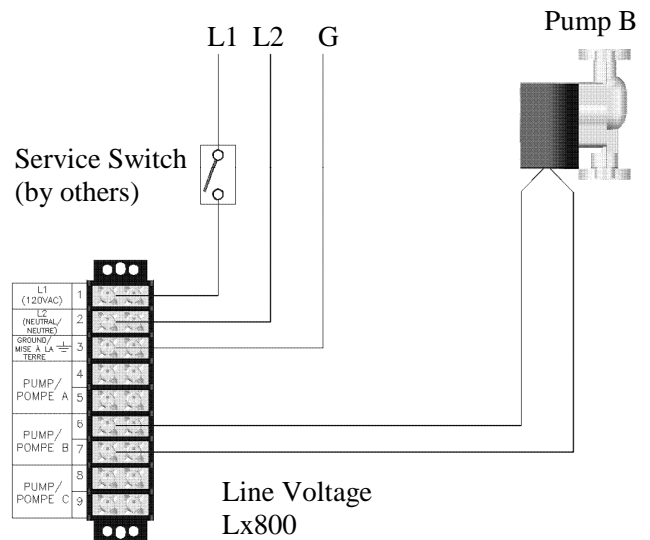
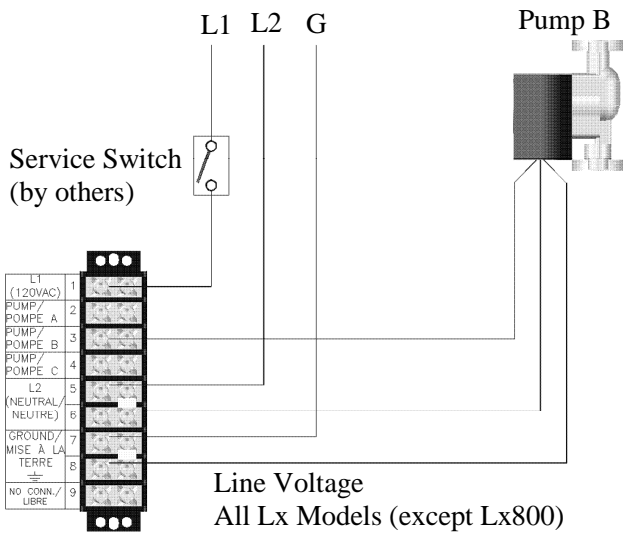



Trinity Lx High Efficiency Gas Condensing Water Heater

Application Guide

2 ELECTRICAL

Multiple Water Heater Wiring Diagrams

