



Trinity Lx300 High Efficiency Gas Condensing Boiler & Water Heater

Submittal Sheet

Section 1 - Specifications
Section 2 - Dimensions
Section 3 - Electrical

Project Name: _____ Date: _____
 Location: _____
 Engineer: _____
 Contractor: _____ Rep: _____

1 SPECIFICATIONS

General Specifications

- ▶ Product Features
 - Certified to ANSI Z21.13 / CSA 4.9 Gas-fired Boiler Standard
 - Certified to ANSI Z21.10.3 / CSA 4.3 Gas Water Heater Standard
 - ASME "H" stamped boiler, designed and constructed in compliance with the ASME Boiler and Pressure Vessel Code Section IV
 - SA-249 TP316L Stainless Steel Heat Exchanger
 - Maximum operating pressure 160 psi [1103 kPa]
 - Field conversion from Natural Gas (factory) to Propane
 - Modulating burner, 5:1 turndown
 - Direct Spark Ignition
 - Wall or floor mounting
 - Zero clearance to combustibles
- ▶ Optional Side Wall Vent Terminal Kit (NTI Part # 83236, 84355 & 84358)
- ▶ Factory Supplied Items
 - 1 – 500ml bottle Fernox F1 Protector
 - 10k Outdoor sensor (System sensor optional)
 - 30PSI & 125PSI ASME Relief Valves
 - 60PSI & 160PSI Pressure Gauges
- ▶ Control Features
 - Integral microprocessor safety control
 - 2 central heat inputs (high & low temperature)
 - Domestic Hot Water Priority
 - Outdoor reset
 - Warm weather shutdown
 - Lead-Lag up to 8 Lx series boilers
 - Integrated Modbus RTU for connection to BMS gateways

Water Connections NPT, in.	Gas Connection NPT, in.	Vent/Air-Intake Pipe Diameter in. [mm]	Vent/Air-Intake Max. Length, NG/LP ft. [m]	Approx. Weight with Water lb. [kg]
1-1/4	1/2	4 [102]	100 [30.5]	180 [81.6]
		6 [152]	100 [30.5]	

Heating Specifications

Input		Heating Capacity BTU/hr [kW]	Recovery Rate @ 100°F Rise USGPH	AFUE %	Net I=B=R Rating BTU/hr [kW]
Min BTU/hr [kW]	Max BTU/hr [kW]				
55,000 [16.1]	275,000 [80.5]	251,000 [73.5]	310	93.7	218,000 [63.8]

Performance Specifications

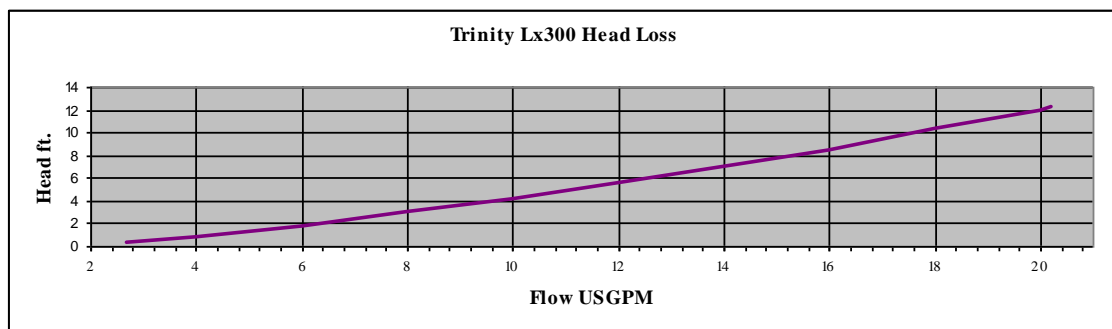

NY Thermal Inc.

65 Drury Cove Road, Saint John, NB E2H 2Z8 Canada

Technical Service: 1-800-688-2575 Fax: 1-506-432-1135 Web: [http:// www.nythermal.com](http://www.nythermal.com)



Trinity Lx300 High Efficiency Gas Condensing Boiler & Water Heater

Submittal Sheet

2 DIMENSIONS

Product Dimensions – in. [mm]

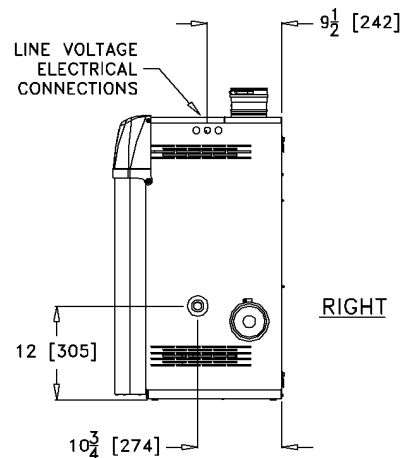
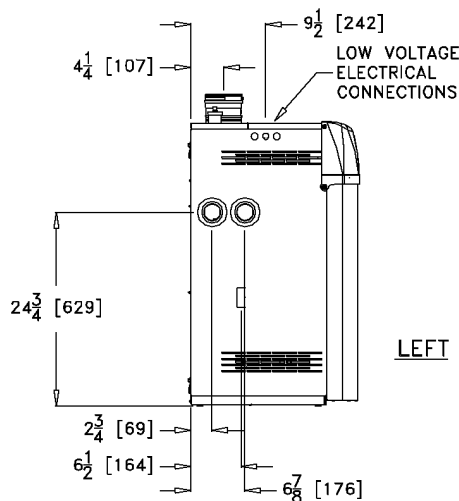
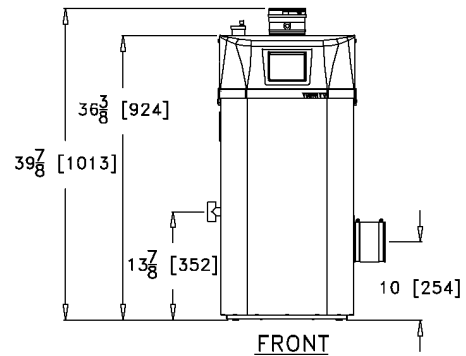
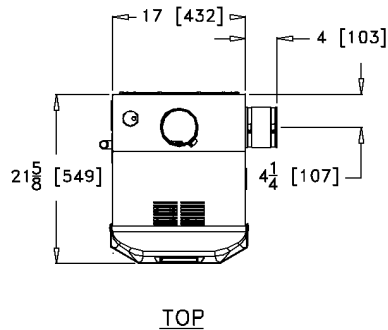

Recommended Clearances – in. [mm]

Top	Front	Left	Right	Back	Bottom
24 [610]	24 [610]	24 [610]	12 [305]	0	0



NY Thermal Inc.

65 Drury Cove Road, Saint John, NB E2H 2Z8 Canada

Technical Service: 1-800-688-2575 Fax: 1-506-432-1135 Web: <http://www.nythermal.com>

NY Thermal Inc. reserves the right to change these specifications without notice



Trinity Lx300 High Efficiency Gas Condensing Boiler & Water Heater

Submittal Sheet

3 ELECTRICAL

Simplified Wiring Diagrams

Line Voltage Electrical:

- ▶ 120VAC / 60 Hz / 1 Phase / 12 Amp
- ▶ Barrier Strip for field wiring terminations
- ▶ 3 Pump outputs
 - Indirect Domestic Hot Water (Pump A)
 - Boiler (Pump B)
 - Central Heat (Pump C)

Note: Pumps are field supplied.

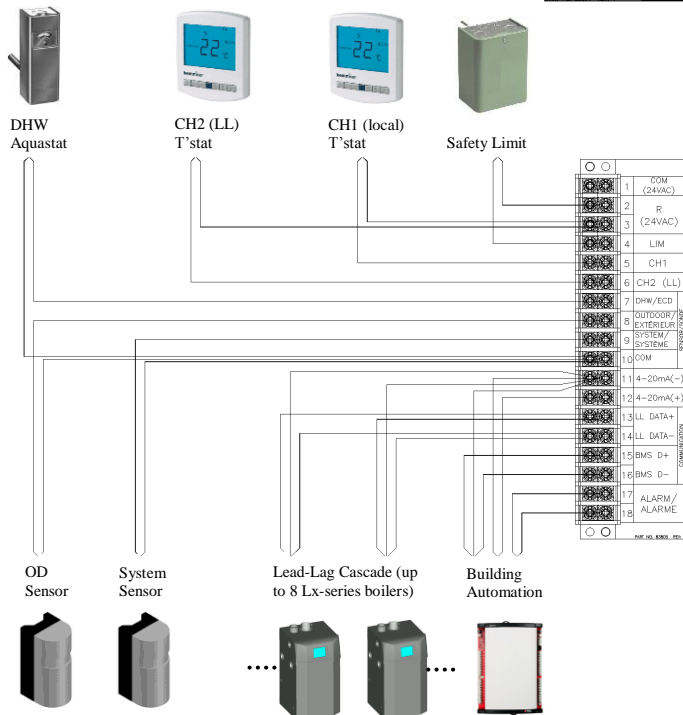
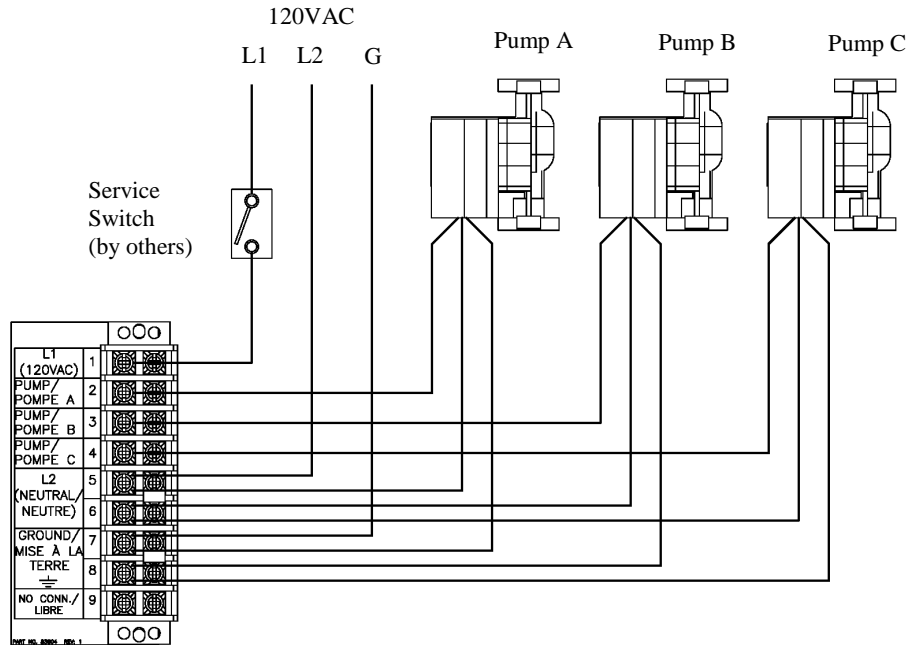

Low Voltage Electrical:

- ▶ Barrier Strip for field wiring terminations
- ▶ 120/24 VAC Transformer 40VA (factory supplied)
- ▶ Inputs
 - CH1 thermostat (by others)
 - CH2 thermostat (by others)
 - Indirect DHW aquastat (by others) or DHW Tank sensor (factory option)
 - External Limit (by others)
 - Outdoor sensor (factory supplied)
 - System sensor (factory option)
 - 4-20mA external modulating control (by others)
- ▶ Outputs
 - Alarm dry contact (24VAC 0.63A max.)
- ▶ EIA-485 Modbus communications for Lead-Lag
- ▶ EIA-485 Modbus to BMS gateways (not shown). Optional available gateways:
 - BACnet/N2- NTI part # 84946
 - LonWorks- NTI part # 84947



NY Thermal Inc.

65 Drury Cove Road, Saint John, NB E2H 2Z8 Canada

Technical Service: 1-800-688-2575 Fax: 1-506-432-1135 Web: <http://www.nythermal.com>

NY Thermal Inc. reserves the right to change these specifications without notice