



Trinity Lx700 High Efficiency Gas Condensing Boiler & Water Heater

Submittal Sheet

Section 1 - Specifications
Section 2 - Dimensions
Section 3 - Electrical

Project Name: _____ Date: _____
 Location: _____
 Engineer: _____
 Contractor: _____ Rep: _____

1 SPECIFICATIONS

General Specifications

- ▶ Product Features
 - Factory set to operate with Natural Gas (**NOTICE: not approved for use with Propane**)
 - Certified to ANSI Z21.13 / CSA 4.9 Gas-fired Boiler Standard
 - Certified to ANSI Z21.10.3 / CSA 4.3 Gas Water Heater Standard
 - ASME "H" stamped boiler, designed and constructed in compliance with the ASME Boiler and Pressure Vessel Code Section IV
 - SA-249 TP316L Stainless Steel Heat Exchanger
 - CSD-1 compliant
 - Maximum operating pressure 160 psi [1103 kPa]
 - Modulating burner, 4.4:1 turndown
 - Direct Spark Ignition
 - Zero clearance to combustibles
- ▶ Optional Side Wall Vent Terminal Kits NTI part # 83236, 84355, 84358
- ▶ Factory Supplied Items
 - 10k thermistor Outdoor and System sensors
 - 2 - 500ml bottles Fernox F1 Protector
 - Flow switch
 - 50PSI & 150PSI ASME Relief Valves
 - 60PSI & 160PSI Pressure Gauge
- ▶ Control Features
 - Integral microprocessor safety control
 - 2 central heat inputs (high & low temperature)
 - Domestic Hot Water Priority
 - Outdoor reset
 - Warm weather shutdown
 - Time of day input
 - Lead-Lag up to 8 Lx series boilers
 - Integrated Modbus RTU for connection to BMS gateways

Water Connections NPT, in.	Gas Connection NPT, in.	Vent/Air-inlet Pipe Diameter, in.	Vent/Air-inlet Max. Length, ft.	Approx. Weight with Water, lb.
2 (Female)	1 (Male)	Air-inlet 4	100	425
		Vent 6	100	

Heating Specifications

Input Modulation, MBH	Gross Output Capacity, MBH	Combustion Efficiency, %	Thermal Efficiency, %	Net I=B=R Rating, MBH	Recovery Rate @ 100°F Rise, USGPH
160 – 700	658	95	94	572	789

Performance Specifications

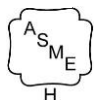
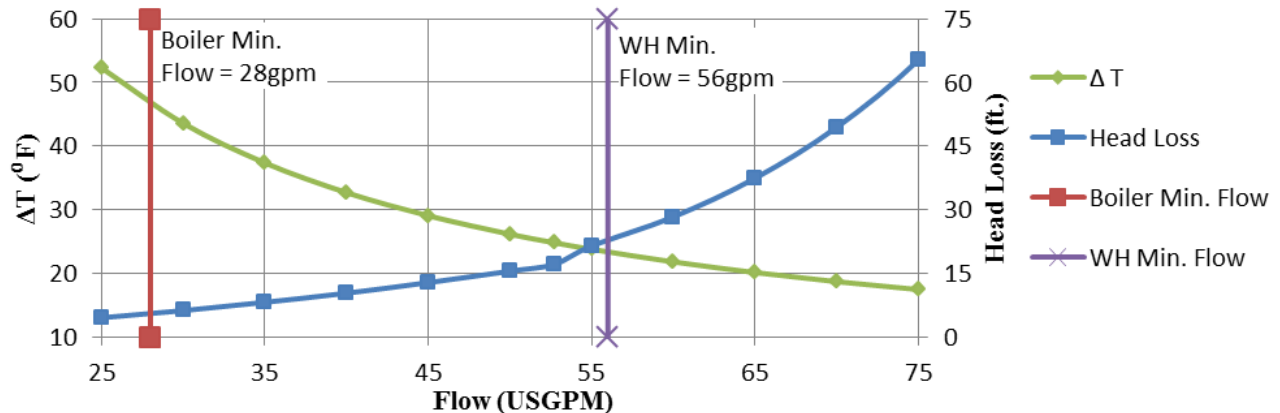

NY Thermal Inc.

65 Drury Cove Road, Saint John, NB E2H 2Z8 Canada

2014-01-29
Rev.5

Technical Service: 1-800-688-2575 Fax: 1-506-432-1135 Web: <http://www.nythermal.com>

NY Thermal Inc. reserves the right to change these specifications without notice



**Trinity Lx700
High Efficiency Gas
Condensing Boiler & Water Heater**

Submittal Sheet

2 DIMENSIONS

Product Dimensions – in. [mm]

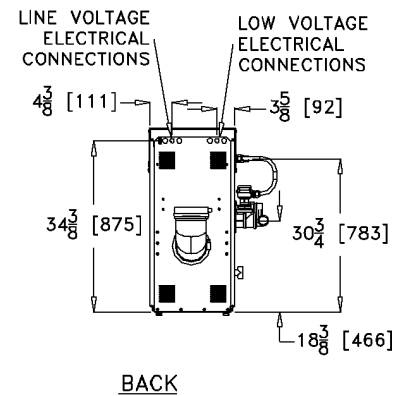
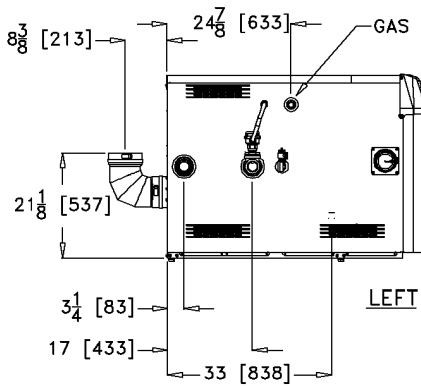
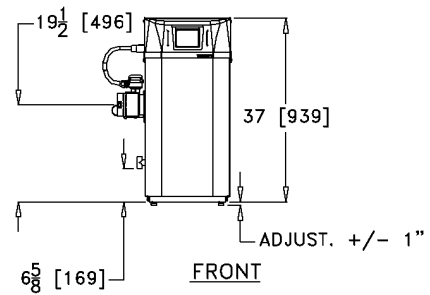
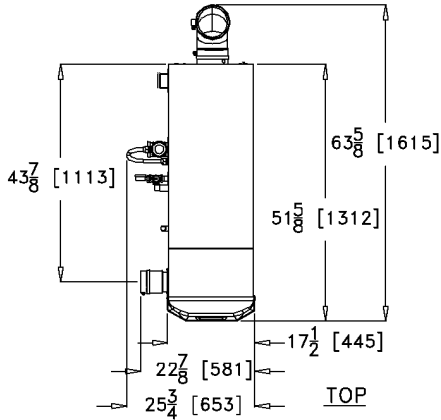

Recommended Clearances – in. [mm]

Top	Front	Left	Right	Back	Bottom
24 [610]	24 [610]	24 [610]	12 [305]	24	0

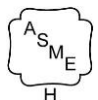

NY Thermal Inc.

65 Drury Cove Road, Saint John, NB E2H 2Z8 Canada

2014-01-29
Rev.5

Technical Service: 1-800-688-2575 Fax: 1-506-432-1135 Web: <http://www.nythermal.com>

NY Thermal Inc. reserves the right to change these specifications without notice



Trinity Lx700 High Efficiency Gas Condensing Boiler & Water Heater

Submittal Sheet

3 ELECTRICAL

Simplified Wiring Diagrams

Line Voltage Electrical:

- ▶ 120VAC / 60 Hz / 1 Phase / 12 Amp
- ▶ Barrier Strip for field wiring terminations
- ▶ 3 Pump outputs
 - Indirect Domestic Hot Water (Pump A)
 - Boiler (Pump B)
 - Central Heat (Pump C)

Note: Pumps are field supplied.

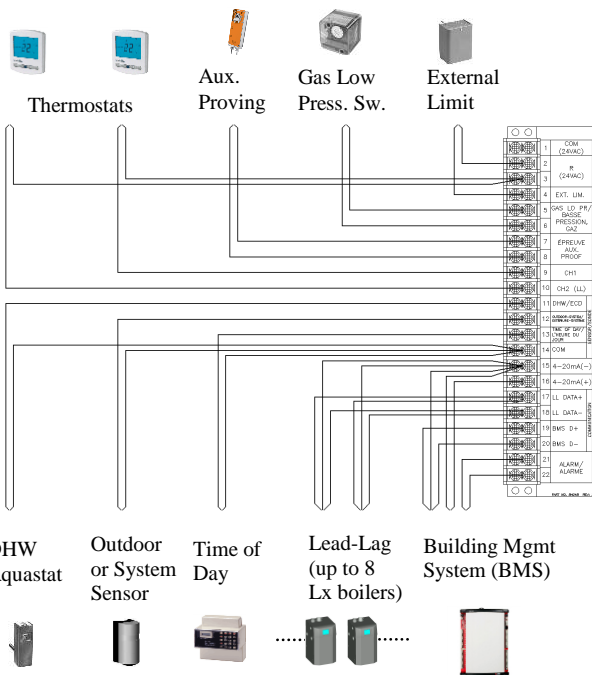
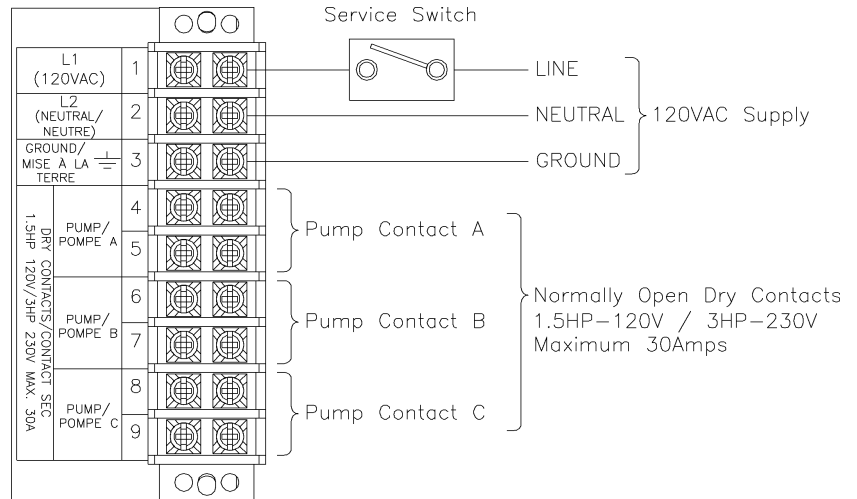

Low Voltage Electrical:

- ▶ Barrier Strip for field wiring terminations
- ▶ 120/24 VAC Transformer 40VA (factory supplied)
- ▶ Inputs
 - CH1 thermostat (by others)
 - CH2 thermostat (by others)
 - Indirect DHW aquastat (by others) or DHW Tank sensor (factory option)
 - External Limit (by others)
 - Outdoor sensor (factory supplied)
 - System sensor (factory option)
 - 4-20mA external modulating control (by others)
- ▶ Outputs
 - Alarm dry contact (24VAC 0.63A max.)
- ▶ EIA-485 Modbus communications for Lead-Lag
- ▶ EIA-485 Modbus to BMS gateways (not shown).
Optional available gateways:
 - BACnet/N2- NTI part # 84946
 - LonWorks- NTI part # 84947

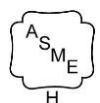

NY Thermal Inc.

65 Drury Cove Road, Saint John, NB E2H 2Z8 Canada

2014-01-29
Rev.5

Technical Service: 1-800-688-2575 Fax: 1-506-432-1135 Web: <http://www.nythermal.com>

NY Thermal Inc. reserves the right to change these specifications without notice