



# Trinity Lx500 High Efficiency Gas Condensing Boiler & Water Heater

## Submittal Sheet

Section 1 - Specifications  
Section 2 - Dimensions  
Section 3 - Electrical

Project Name: \_\_\_\_\_ Date: \_\_\_\_\_  
 Location: \_\_\_\_\_  
 Engineer: \_\_\_\_\_  
 Contractor: \_\_\_\_\_ Rep: \_\_\_\_\_

### 1 SPECIFICATIONS

#### General Specifications

- ▶ Product Features
  - Certified to ANSI Z21.13 / CSA 4.9 Gas-fired Boiler Standard
  - Certified to ANSI Z21.10.3 / CSA 4.3 Gas Water Heater Standard
  - ASME "H" stamped boiler, designed and constructed in compliance with the ASME Boiler and Pressure Vessel Code Section IV
  - SA-249 TP316L Stainless Steel Heat Exchanger
  - CSD-1 compliant
  - Maximum operating pressure 160 psi [1103 kPa]
  - Modulating burner, 5:1 turndown
  - Direct Spark Ignition
  - Zero clearance to combustibles
- ▶ Optional Side Wall Vent Terminal Kits NTI part # 83236, 84355, 84358
- ▶ Factory Supplied Items
  - 10k thermistor Outdoor and System sensors
- ▶ Factory Supplied Items (cont'd)
  - 2 - 500ml bottles Fernox F1 Protector
  - Flow switch
  - 50PSI & 150PSI ASME Relief Valves
  - 60PSI & 160PSI Pressure Gauge
- ▶ Control Features
  - Integral microprocessor safety control
  - 2 central heat inputs (high & low temperature)
  - Domestic Hot Water Priority
  - Outdoor reset
  - Warm weather shutdown
  - Time of day input
  - Lead-Lag up to 8 Lx series boilers
  - Integrated Modbus RTU for connection to BMS gateways

Water Connections NPT, in.	Gas Connection NPT, in.	Vent/Air-inlet Pipe Diameter, in.	Vent/Air-inlet Max. Length, ft.	Approx. Weight with Water, lb.
2 (Female)	¾ (Male)	4	100	320

#### Heating Specifications

Input Modulation, MBH	Gross Output Capacity, MBH	Combustion Efficiency, %	Thermal Efficiency, %	Net I=B=R Rating, MBH	Recovery Rate @ 100°F Rise, USGPH
100 - 500	470	95	94	409	564

#### Performance Specifications

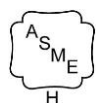
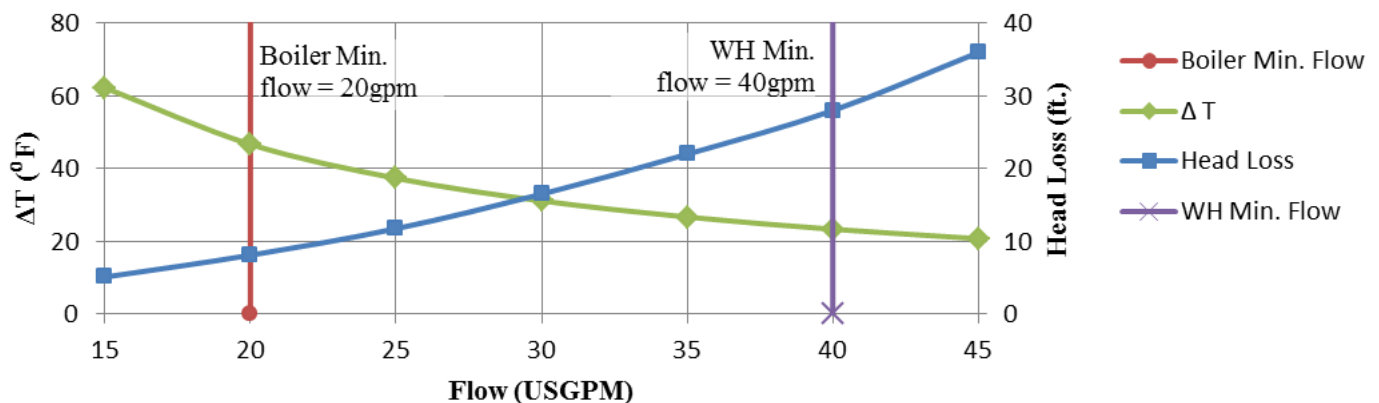

NY Thermal Inc.

65 Drury Cove Road, Saint John, NB E2H 2Z8 Canada

2013-09-24  
Rev.5

Technical Service: 1-800-688-2575 Fax: 1-506-432-1135 Web: <http://www.nythermal.com>

NY Thermal Inc. reserves the right to change these specifications without notice



# Trinity Lx500 High Efficiency Gas Condensing Boiler & Water Heater

Submittal Sheet

## 2 DIMENSIONS

### Product Dimensions – in. [mm]

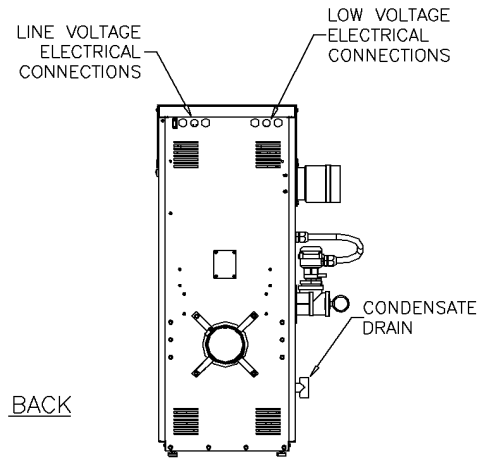
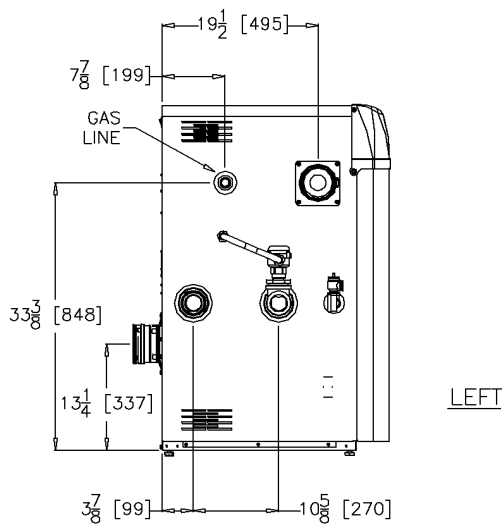
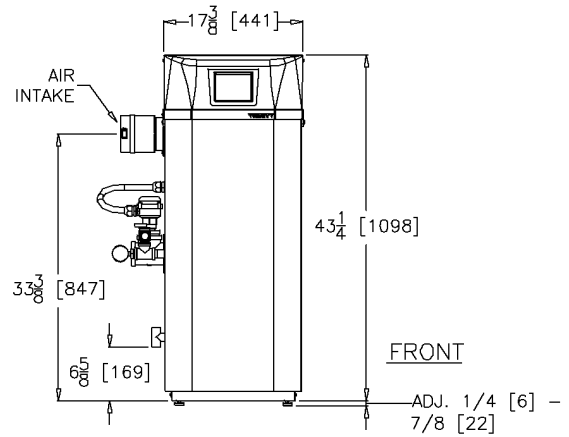
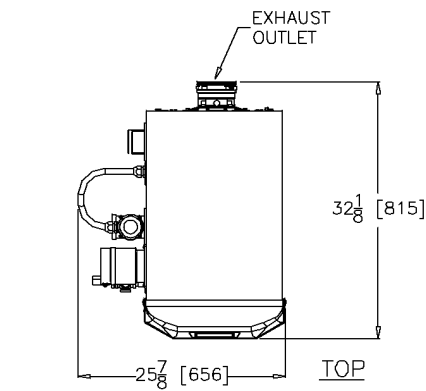

### Recommended Clearances – in. [mm]

Top	Front	Left	Right	Back	Bottom
24 [610]	24 [610]	24 [610]	12 [305]	24	0

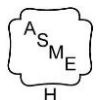

NY Thermal Inc.

65 Drury Cove Road, Saint John, NB E2H 2Z8 Canada

2013-09-24  
Rev.5

Technical Service: 1-800-688-2575 Fax: 1-506-432-1135 Web: <http://www.nythermal.com>

NY Thermal Inc. reserves the right to change these specifications without notice



# Trinity Lx500 High Efficiency Gas Condensing Boiler & Water Heater

Submittal Sheet

## 3 ELECTRICAL

### Simplified Wiring Diagrams

#### Line Voltage Electrical:

- ▶ 120VAC / 60 Hz / 1 Phase / 12 Amp
- ▶ Barrier Strip for field wiring terminations
- ▶ 3 Pump outputs
  - Indirect Domestic Hot Water (Pump A)
  - Boiler (Pump B)
  - Central Heat (Pump C)

Note: Pumps are field supplied.

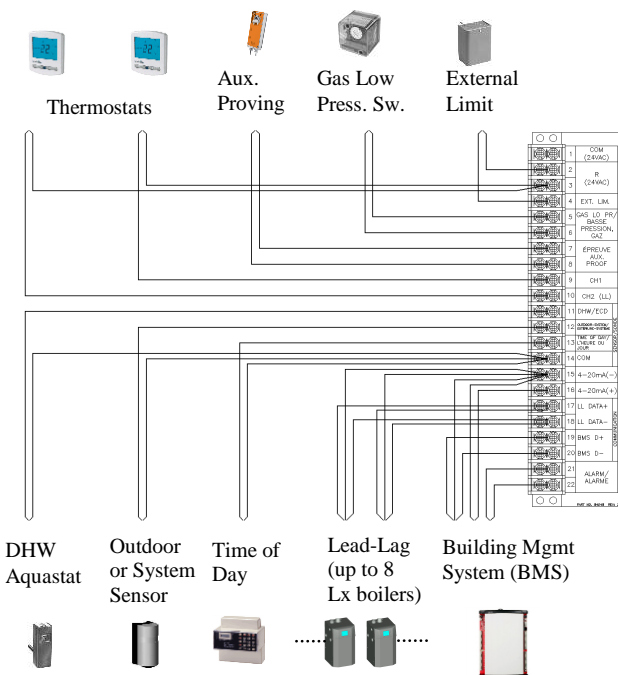
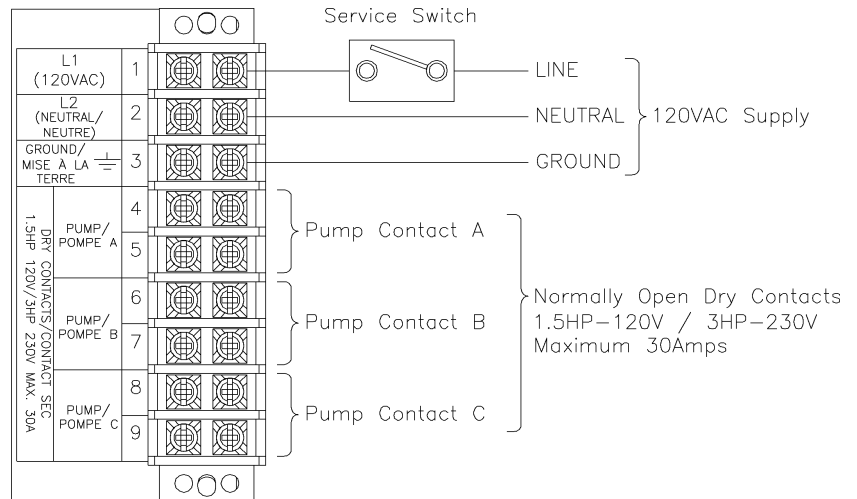

#### Low Voltage Electrical:

- ▶ Barrier Strip for field wiring terminations
  - ▶ 120/24 VAC Transformer 40VA (factory supplied)
  - ▶ Inputs
    - CH1 thermostat (by others)
    - CH2 thermostat (by others)
    - Indirect DHW aquastat (by others) or DHW Tank sensor (factory option)
    - External Limit (by others)
    - Outdoor sensor (factory supplied)
    - System sensor (factory option)
    - 4-20mA external modulating control (by others)
  - ▶ Outputs
    - Alarm dry contact (24VAC 0.63A max.)
  - ▶ EIA-485 Modbus communications for Lead-Lag
  - ▶ EIA-485 Modbus to BMS gateways (not shown).
- Optional available gateways:
- BACnet/N2- NTI part # 84946
  - LonWorks- NTI part # 84947

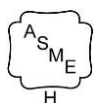

NY Thermal Inc.

65 Drury Cove Road, Saint John, NB E2H 2Z8 Canada

2013-09-24  
Rev.5

Technical Service: 1-800-688-2575 Fax: 1-506-432-1135 Web: <http://www.nythermal.com>

NY Thermal Inc. reserves the right to change these specifications without notice