



Trinity Ti200 Combi High Efficiency Gas Condensing Boiler

Submittal Sheet

Section 1 - Specifications
Section 2 - Dimensions
Section 3 - Electrical

Project Name: _____ Date: _____
 Location: _____
 Engineer: _____
 Contractor: _____ Rep: _____

1 SPECIFICATIONS

General Specifications

- ▶ Product Features
 - Certified to ANSI Z21.13 / CSA 4.9 indicating compliance with applicable ANSI/UL standards
 - "H" Stamped in compliance with ASME Section IV
 - Maximum operating pressure 145 psi [1000 kPa]
 - Field conversion from Natural Gas (factory) to Propane
 - Modulating burner, 5:1 turndown
 - Hot Surface Ignition
 - Wall or floor mounting (w/ optional floor stand)
 - Zero clearance to combustibles
- ▶ Optional sidewall vent kit (NTI part # 82666)
- ▶ Factory Supplied Items
 - 1 – 500ml bottle Fernox F1 Protector
 - 10K thermistor outdoor sensor
 - 30PSI ASME Relief Valve
 - 60PSI Pressure Gauge
 - Thermostatic Mixing Valve
 - Domestic Hot Water Flow Switch
- ▶ Control Features
 - Domestic Hot Water Priority
 - Outdoor reset

Water Connections NPT, in.	Gas Connection NPT, in.	Vent/Air-Intake Pipe Diameter in. [mm]	Vent/Air-Intake Max. Length, NG/LP ft. [m]	Approx. Weight with Water lb. [kg]
1	1/2	3 [76]	105 / 50 [32 / 15.2]	110 [49.9]

Heating Specifications

Input		Heating Capacity BTU/hr [kW]	AFUE %	Net I=B=R Rating BTU/hr [kW]
Min BTU/hr [kW]	Max BTU/hr [kW]			
25,000 [7.3]	199,000 [58.3]	181,000 [53]	93.5	157,000 [46]

Performance Specifications

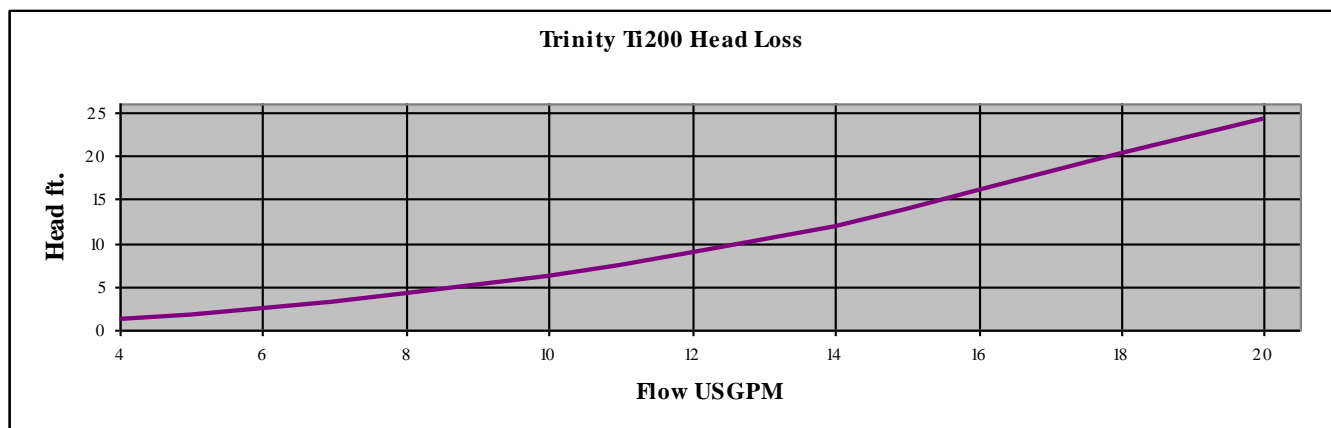

NY Thermal Inc.

65 Drury Cove Road Saint John, NB E2H 2Z8 Canada

2013-05-27
Rev.2

Technical Service: 1-800-688-2575 Fax: 1-506-432-1135 Web: <http://www.nythermal.com>

NY Thermal Inc. reserves the right to change these specifications without notice



Trinity Ti200 Combi High Efficiency Gas Condensing Boiler

Submittal Sheet

2 DIMENSIONS

Product Dimensions – in. [mm]

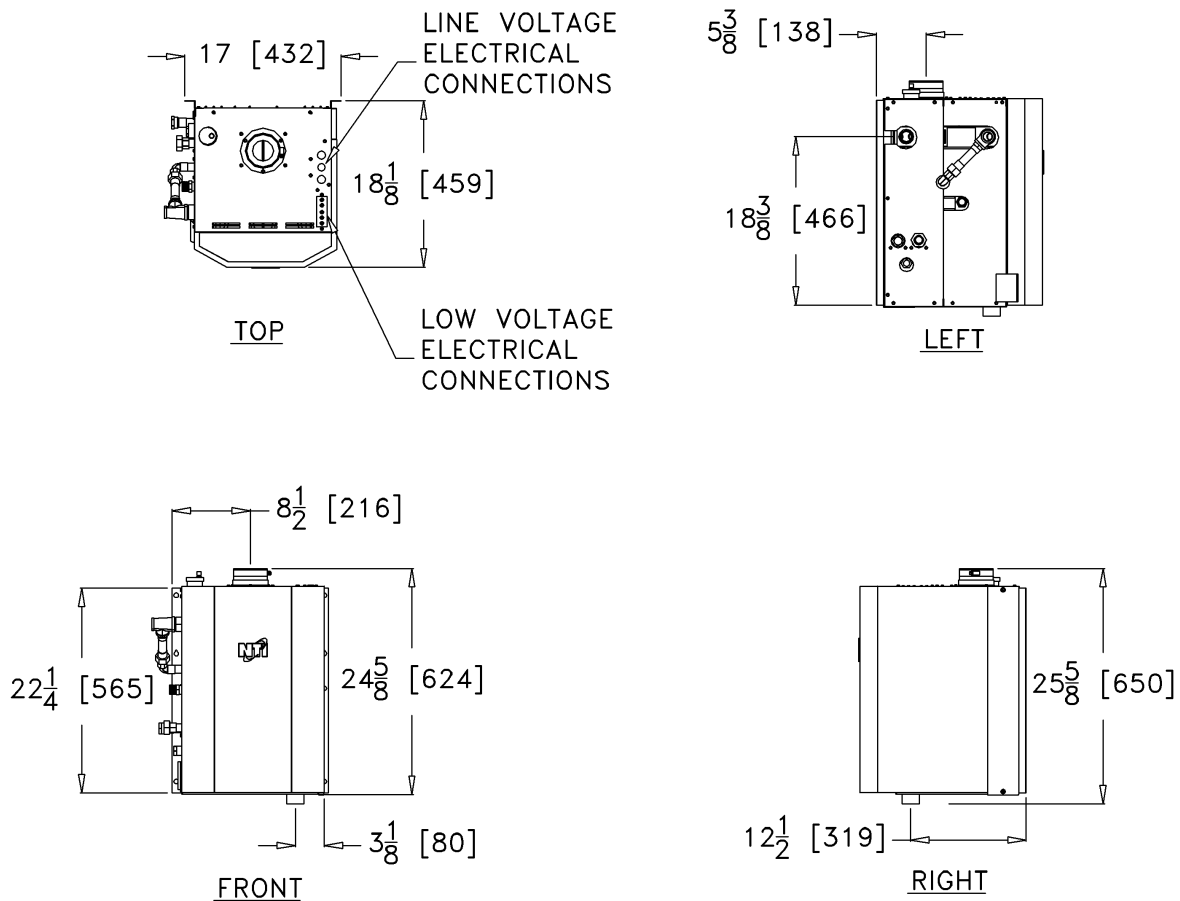

Recommended Clearances – in. [mm]

Top	Front	Left	Right	Back	Bottom
24 [610]	24 [610]	24 [610]	24 [610]	0	9 [229]



NY Thermal Inc.

65 Drury Cove Road Saint John, NB E2H 2Z8 Canada

Technical Service: 1-800-688-2575 Fax: 1-506-432-1135 Web: <http://www.nythermal.com>

NY Thermal Inc. reserves the right to change these specifications without notice



Trinity Ti200 Combi High Efficiency Gas Condensing Boiler

Submittal Sheet

3 ELECTRICAL

Simplified Wiring Diagrams

Line Voltage Electrical:

- ▶ 120VAC / 60 Hz / 1 Phase / 12 Amp
- ▶ 1 Pump output
 - Primary circulator

Note: Pumps are field supplied.

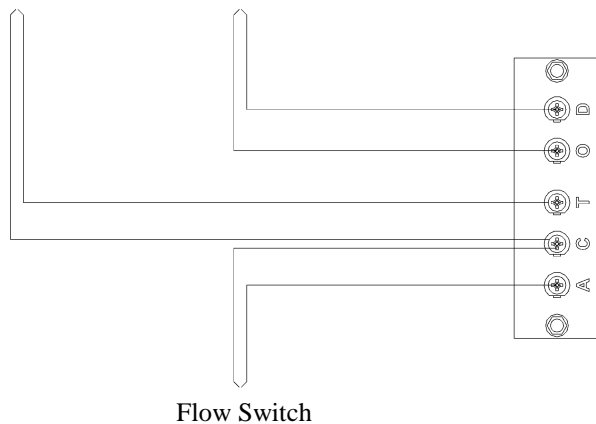
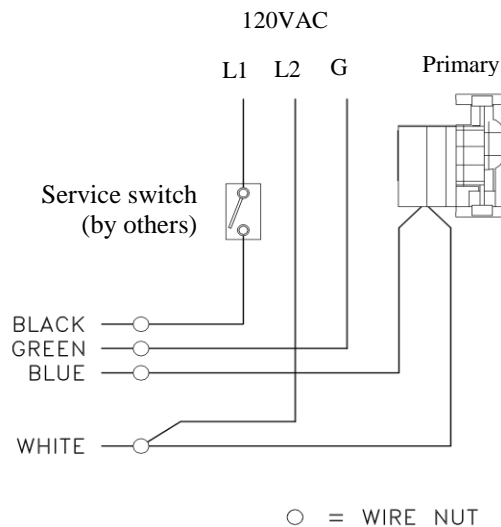

Low Voltage Electrical:

- ▶ Barrier Strip for field wiring terminations
- ▶ Inputs
 - Thermostat (by others)
 - Flow switch (factory supplied)
 - Outdoor sensor (factory supplied)



NY Thermal Inc.

65 Drury Cove Road Saint John, NB E2H 2Z8 Canada

Technical Service: 1-800-688-2575 Fax: 1-506-432-1135 Web: <http://www.nythermal.com>

NY Thermal Inc. reserves the right to change these specifications without notice