



This manual covers model numbers:
United States PGC* 34-100-2NV or 2PV PGC* 34-130-2NV or 2PV PGC* 34-150-2NV or 2PV PGC* 50-130-2NV or 2PV PGC* 50-150-2NV or 2PV PGC* 50-175-3NV or 3PV PGC* 50-199-3NV or 3PV
* Indicates warranty period
<b>Note:</b> The manufacturer of this water heater recommends that it be professionally installed by trained and qualified service professionals.

# Polaris® Commercial Gas Water Heater Installation Instructions and Use & Care Guide

To obtain technical, warranty or service assistance during or after the installation of this water heater, visit our website at:

<http://www.americanwaterheater.com>

or call toll free:  
1-800-456-9805

When calling for assistance, please have the following information ready:

1. Model number
2. 7 Digit product number
3. Serial number
4. Date of installation
5. Place of Purchase

Table of Contents..... 2

### INSTALLER:

- Affix these instructions to or adjacent to the water heater.

### OWNER:

- Retain these instructions and warranty for future reference. Retain the original receipt as proof of purchase.

**WARNING:** If the information in these instructions is not followed exactly, a fire or explosion may result causing property damage, personal injury or death.

Do not store or use gasoline or other flammable vapors and liquids in the vicinity of this or any other appliance.

### WHAT TO DO IF YOU SMELL GAS

- Do not try to light any appliance.
- Do not touch any electrical switch; do not use any telephone in your building.
- Immediately call your gas supplier from a neighbor's telephone. Follow the gas supplier's instructions.
- If you cannot reach your gas supplier, call the fire department.

Installation and service must be performed by a qualified installer, service agency or the gas supplier.



## Your safety and the safety of others are very important.

We have provided many important safety messages in this manual and on your appliance. Always read and obey all safety messages.



This is the safety alert symbol.

This symbol alerts you to potential hazards that can kill or hurt you and others.

All safety messages will follow the safety alert symbol and either the word "DANGER" or "WARNING." These words mean:

**DANGER**

Indicates an imminently hazardous situation which, if not avoided, will result in death or injury.

**WARNING**

Indicates a hazardous situation which, if not avoided, could result in death or serious injury.

All safety messages will tell you what the potential hazard is, tell you how to reduce the chance of injury, and tell you what can happen if the instructions are not followed.

### Important Instructions

- Do not use this water heater if any part has been under water. Immediately call a qualified service technician. Water heaters subjected to flood conditions or anytime the gas controls, main burner or ignition control have been submerged in water require replacement of the entire water heater.
- Hydrogen gas can be produced in a hot water system that has not been used for a long period of time (generally two weeks or more). Hydrogen gas is extremely flammable and can ignite when exposed to a spark or flame. To prevent the possibility of injury under these conditions, we recommend the hot water faucet be opened for several minutes at the kitchen sink before using any electrical appliance which is connected to the hot water system. If hydrogen is present, there will probably be an unusual sound such as air escaping through the faucet as water begins to flow. Do not smoke or have any open flame near the faucet at the time it is open.

The California Safe Drinking Water and Toxic Enforcement Act requires the Governor of California to publish a list of substances known to the State of California to cause cancer, birth defects, or other reproductive harm, and requires businesses to warn of potential exposure to such substances.

**Warning:** This product contains a chemical known to the State of California to cause cancer, birth defects, or other reproductive harm.

This appliance can cause low-level exposure to some of the substances listed in the act.

### Table of Contents

	Page
Water Heater Safety .....	1-2
Installation Instructions .....	3-22
Unpacking the Water Heater .....	3
State of Massachusetts Installation Requirements .....	4
Location Requirements .....	5
Condensate Line .....	6-7
Intergrated Filter Installation .....	8
Vent Pipe System .....	9-12
Vent Terminations .....	10-13
Gas Input Rate .....	14
Water System Piping .....	14-17
Gas Supply and Piping .....	18-19
Electrical Connections/Wiring Diagram .....	20-21
Installation Checklist .....	22
Operating Your Water Heater .....	23-25
Polaris® Operating Instructions .....	24
Maintenance of Your Water Heater .....	25-26
Troubleshooting .....	27
Software Operation Sequence .....	28
Parts List and Diagram .....	29
Polaris® Models and Dimensions .....	30

# INSTALLATION INSTRUCTIONS

## Consumer Information

### OBSERVE ALL GOVERNING CODES AND ORDINANCES.

This water heater is design-certified by CSA International as a Category IV, direct vented water heater which takes its combustion air from the outside of the structure and exhausts all products of combustion to the outside of the structure.

This water heater must be installed according to all local and state codes or in the absence of local and state codes with the "National Fuel Gas Code", ANSI Z223.1(NFPA 54)- current edition. Canadian installations must be performed in accordance with CAN/CSA-B149.1 -current edition. This is available from the following:

CSA America, Inc.  
8501 East Pleasant Valley Road  
Cleveland, OH 44131

National Fire Protection Agency  
1 Batterymarch Park  
Quincy, MA 02169-7471

Canadian Standards Association  
178 Rexdale Boulevard  
Toronto, ON M9W 1R3

Check the phone listings for the local authorities having jurisdiction over this installation.

## Installer and Owner Responsibilities

This manual has been prepared to acquaint you with the installation, operation, and maintenance of your gas water heater and provide important safety information in these areas.

Read all of the instructions thoroughly before attempting the installation or operation of this water heater.

**Do not discard this manual. You or future users of this water heater will need it for future reference.**

**Service to the water heater should only be performed by a qualified service technician.**

**Examples of qualified service technicians include: those trained in the plumbing and heating industry, local gas utility personnel, or an authorized service person.**

**The manufacturer and seller of this water heater will not be liable for any damages, injuries, or deaths caused by failure to comply with the installation and operating instructions outlined in this manual.**

If you lack the necessary skills required to properly install this water heater, or you have difficulty following the instructions, you should not proceed but have a qualified service technician perform the installation of this water heater.

A data plate identifying your water heater can be found on the front of the heater. When referring to your water heater, always have the information listed on the data plate readily available.

Massachusetts code requires this water heater to be installed in accordance with Massachusetts Plumbing and Fuel Gas Code 248 CMR section 2.00 and 5.00. See page 4 in this manual for the Commonwealth of Massachusetts installation requirements.

This product is certified to comply with a maximum weighted average of 0.25% lead content as required in some areas.

Keep combustibles such as boxes, magazines, clothes, etc., away from water heater area.

Retain your original receipt as proof of purchase.

## Unpacking the Water Heater

### **WARNING**

#### **Excessive Weight Hazard**

**Use two or more people to move and install water heater unless proper handling equipment is utilized.**

**Failure to do so can result in back or other injury.**

## Removing Packaging Materials

Important: Do not remove any permanent instructions, labels, or the data plate from outside of the water heater or on the inside of panels.

- Remove exterior packaging and place installation components aside.
- Inspect all parts for damage prior to installation and start-up.
- Completely read all instructions before attempting to assemble and install this product.
- After installation, dispose of packaging material in the proper manner.

## INSTALLATION REQUIREMENTS FOR THE COMMONWEALTH OF MASSACHUSETTS

For all side wall terminated, horizontally vented power vent, direct vent, and power direct vent gas fueled water heaters installed in every dwelling, building or structure used in whole or in part for residential purposes, including those owned or operated by the Commonwealth and where the side wall exhaust vent termination is less than seven (7) feet above finished grade in the area of the venting, including but not limited to decks and porches, the following requirements shall be satisfied:

**INSTALLATION OF CARBON MONOXIDE DETECTORS** At the time of installation of the side wall horizontal vented gas fueled equipment, the installing plumber or gasfitter shall observe that a hard wired carbon monoxide detector with an alarm and battery back-up is installed on the floor level where the gas equipment is to be installed. In addition, the installing plumber or gasfitter shall observe that a battery operated or hard wired carbon monoxide detector with an alarm is installed on each additional level of the dwelling, building or structure served by the sidewall horizontal vented gas fueled equipment. It shall be the responsibility of the property owner to secure the services of qualified licensed professionals for the installation of hard wired carbon monoxide detectors.

In the event that the side wall horizontally vented gas fueled equipment is installed in a crawl space or an attic, the hard wired carbon monoxide detector with alarm and battery back-up may be installed on the next adjacent floor level.

In the event that the requirements of this subdivision can not be met at the time of completion of installation, the owner shall have a period of thirty (30) days to comply with the above requirements provided that during said thirty (30) day period, a battery operated carbon monoxide detector with an alarm shall be installed.

**APPROVED CARBON MONOXIDE DETECTORS** Each carbon monoxide detector as required in accordance with the above provisions shall comply with NFPA 720 and be ANSI/UL 2034 listed and CSA certified.

**SIGNAGE** A metal or plastic identification plate shall be permanently mounted to the exterior of the building at a minimum height of eight (8) feet above grade directly in line with the exhaust vent terminal for the horizontally vented gas fueled heating appliance or equipment. The sign shall read, in print size no less than one-half (1/2) inch in size, "**GAS VENT DIRECTLY BELOW. KEEP CLEAR OF ALL OBSTRUCTIONS.**"

**INSPECTION** The state or local gas inspector of the side wall horizontally vented gas fueled equipment shall not approve the installation unless, upon inspection, the inspector observes carbon monoxide detectors and signage installed in accordance with the provisions of 248 CMR 5.08(2)(a) 1 through 4.

**EXEMPTIONS:** The following equipment is exempt from 248 CMR 5.08(2)(a)1 through 4:

1. The equipment listed in Chapter 10 entitled "Equipment Not Required To Be Vented" in the most current edition of NFPA 54 as adopted by the Board; and
2. Product Approved side wall horizontally vented gas fueled equipment installed in a room or structure separate from the dwelling, building, or structure used in whole or in part for residential purposes.

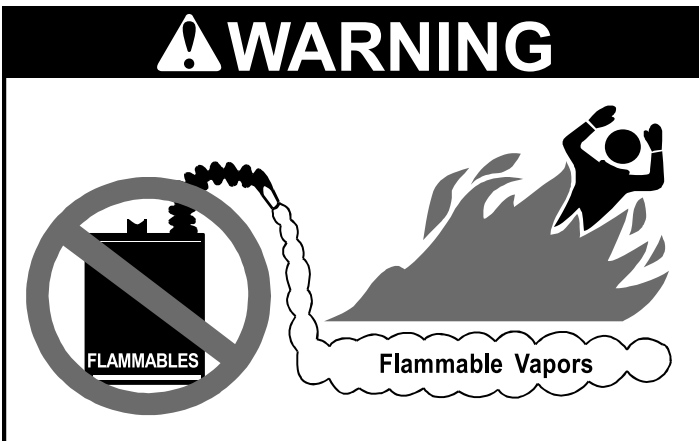
**MANUFACTURER REQUIREMENTS - GAS EQUIPMENT VENTING SYSTEM PROVIDED** When the manufacturer of Product Approved side wall horizontally vented gas equipment provides a venting system design or venting system components with the equipment, the instructions provided by the manufacturer for installation of the equipment and the venting system shall include:

1. Detailed instructions for the installation of the venting system design or the venting system components; and
2. A complete parts list for the venting system design or venting system.

**MANUFACTURER REQUIREMENTS - GAS EQUIPMENT VENTING SYSTEM NOT PROVIDED** When the manufacturer of a Product Approved side wall horizontally vented gas fueled equipment does not provide the parts for venting the flue gases, but identifies "special venting systems," the following requirements shall be satisfied by the manufacturer:

1. The referenced "special venting system" instructions shall be included with the appliance or equipment installation instructions; and
2. The "special venting systems" shall be Product Approved by the Board, and the instructions for that system shall include a parts list and detailed installation instructions.

A copy of all installation instructions for all Product Approved side wall horizontally vented gas fueled equipment, all venting instructions, all parts lists for venting instructions, and/or all venting design instructions shall remain with the appliance or equipment at the completion of the installation.

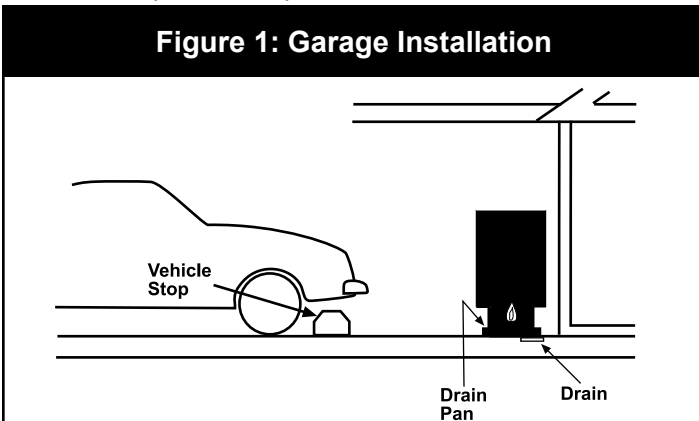


**FIRE AND EXPLOSION HAZARD**  
**Can result in serious injury or death**

**Do not store or use gasoline or other flammable vapors and liquids in the vicinity of this or any other appliance. Storage of or use of gasoline or other flammable vapors or liquids in the vicinity of this or any other appliance can result in serious injury or death**

## Location Requirements

The water heater design has been tested by CSA International and complies with ANSI Z21.10.1, Section 2.35 Flammable Vapors Resistance. In garage installation avoid damage to your water heater by installing a vehicle stop as shown in figure below. Check state and local codes for requirements prior to installation.



This water heater is not certified for installation in mobile homes.

**Note:** In the State of California, the water heater must be braced, anchored, or strapped to avoid moving during an earthquake. Contact local utilities for code requirements in your area or call 1-800-456-9805 and request instructions.

## Site Location

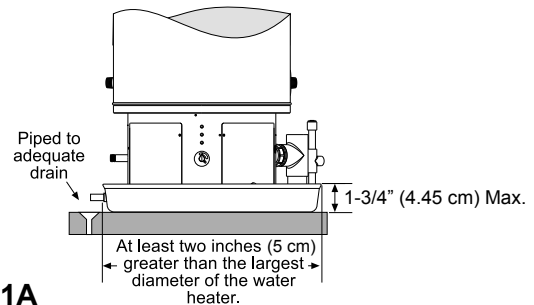
- Select a location near the center of the water piping system. The water heater must be installed indoors and in a vertical position on a level surface. DO NOT install in bathrooms, bedrooms, or any occupied room normally kept closed. **Note:** The water heater may be installed in a closet with a door off a bedroom or bathroom providing the units are installed and vented per the manufacturer's instructions.

- Consider the inlet and exhaust vent system piping when selecting the water heater location. The venting system must be able to run from the water heater to the termination with a minimal length and number of elbows. Input rates are reduced as vent system length increases. The venting system must comply with the requirements set forth in the venting section of this manual.
- Locate the water heater near the existing gas piping. If installing a new gas line, locate the water heater to minimize the pipe length and elbows.

**Important:** Air for combustion and ventilation must not come from a corrosive atmosphere. Any failure due to corrosive elements in the atmosphere is excluded from warranty coverage.

**Note:** The water heater must be installed according to all local and state codes or in absence of the local and state codes with the "National Fuel Gas Code", ANSI Z223.1 (NFPA 54)-current edition. Canadian installations must be performed in accordance with CAN/CSA-B149.1-current edition.

**Important:** The water heater should be located in an area where leakage of the tank or connections will not result in damage to the area adjacent to the water heater or to lower floors of the structure. **Due to the normal corrosive action of the water, the tank will eventually leak after an extended period of time. Also any external plumbing leak, including those from improper installation, may cause early failure of the water tank due to corrosion if not repaired. A qualified service technician should be contacted for repairs.** A suitable metal drain pan should be installed under the water heater as shown below, to help protect the property from damage which may occur from condensate formation or leaks in the piping connections or tank. The pan must limit the water level to a maximum depth of 1-3/4" (4.45 cm) and be at least two inches (5 cm) wider than the heater and piped to an adequate drain. Locate the water heater near a suitable indoor drain. Outside drains are subject to freezing temperatures which can obstruct the drain line. The piping should be at least 3/4" (1.91 cm) ID and pitched for proper drainage. Under no circumstances will the manufacturer or seller of this water heater be held liable for any water damage which is caused by your failure to follow these instructions.



**Figure 1A**

- The water heater should be located in an area not subject to freezing temperatures. Water heaters located in unconditioned spaces (i.e., attics, basements, etc) may require insulation of the water piping and drain piping to protect against freezing. The drain and controls must be easily accessible for operation and service. Maintain proper clearances as specified on the data plate.

## Clearances and Accessibility

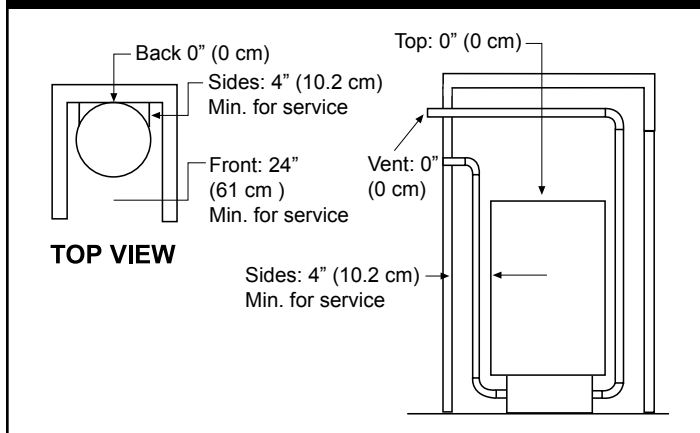
**Notice:** Minimum clearances from combustible materials are stated on the data plate located on the front of the water heater.

- The water heater is certified for installation on a combustible floor.

**Important:** If installing over carpeting, the carpeting must be protected by a metal or wood panel beneath the water heater. The protective panel must extend beyond the full width and depth of the water heater by at least 3 inches (7.62 cm) in any direction or if in a alcove or closet installation, the entire floor must be covered by the panel. The panel must be strong enough to carry the weight of the heater when full of water.

Figure 2 may be used as a reference guide to locate the specific clearance locations. A minimum of 24 inches (61 cm) of front clearance and 4 inches (10.2 cm) on each side should be provided for inspection and service.

**Figure 2: Minimum Clearance Locations**



## CONDENSATE LINE

**Important:** Do not run the condensate drain in areas that are likely to freeze. Frozen condensate will block the drain line and result in property damage or water heater malfunction.

### Condensate Trap Assembly

A condensate trap/drain stem assembly has been supplied with the water heater and is located behind the access door inside the base of the water heater. This assembly must be installed between the water heater and the exhaust outlet piping to ensure proper operation of the water heater. To install, remove the slip-joint nut, stainless steel washer, and O-ring from the trap assembly. Slip the nut, washer and O-ring (in that order) over the stainless exhaust tubing and slide them back near the base of the heater. Insert the trap assembly over the tubing (see figure 3A accordingly) and firmly hand-tighten (using a wrench will cause the O-ring to seal improperly) the nut to form a water-tight seal between the O-ring and the stainless exhaust tubing. When tightened, the nut to heater base clearance should be  $3/4''$  ( $\pm 1/8''$ ) tolerance (1.9 cm  $\pm$  0.31 cm tolerance).

**Note:** The trap should be aligned so that the exhaust pipe is in a vertical position close to the surface of the water heater.

**Figure 3A: 2" Condensation Trap Installation**

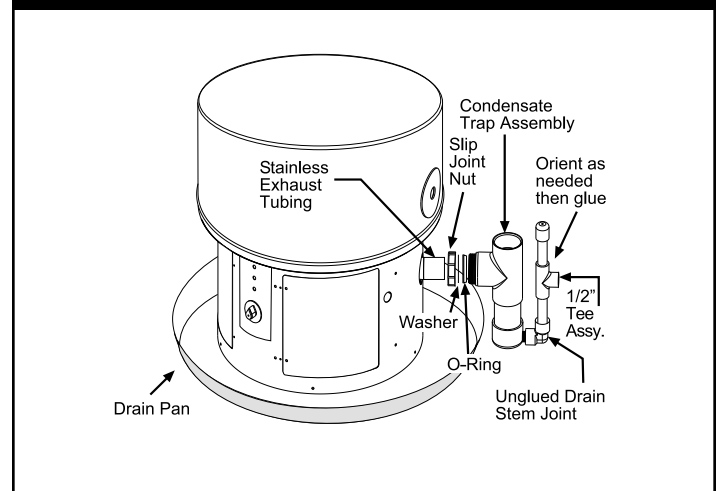
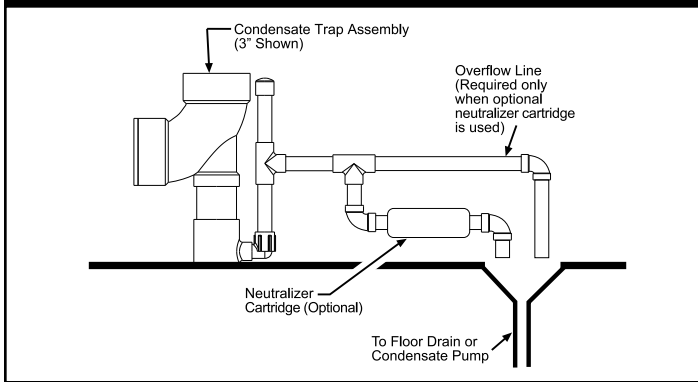


Figure 3B: Condensate Drain



## Condensate Drain Line

All parts of the condensate trap are glued except for the 1/2" CPVC drain stem joint at the elbow (see figure 3A). This assembly can be turned with the outlet of the tee oriented as needed.

Once orientation direction is decided, remove the unglued joint from the elbow at the bottom and apply a suitable cement to joint. Re-insert the joint fully and quickly into the elbow making sure to orient it before the cement sets. Connect the remaining piping and run the condensate drain line to a suitable drain.

**Important:** Be sure the drain stem joint is inserted against the stop in the elbow. Failure to do so may result in improper water heater operation.

If required by local codes, install a condensate neutralizer cartridge on the drain line (see figure 3B).

The condensate drain line must be routed to a suitable drain. If no floor drain is available or the drain is above the level of the condensate line, install a condensate pump that is resistant to the acidic condensate. These pumps are available from local distributors. If the pump is not resistant to acidic water, a condensate neutralizer must be used ahead of the pump.

When installing the drain line, note the following:

- Plastic pipe or tubing must be used to connect the condensate drain to a suitable drain or condensate pump. Do not use copper tubing, iron, or steel pipe for the condensate drain line.
- Condensate drain lines should be installed in conditioned areas only. Drain lines installed in areas that are subject to freezing temperatures should be wrapped with a nationally recognized/listed heat tape and/or approved insulation for freeze protection. Install per manufacturer's instructions.
- Do not common drain with the temperature and pressure relief valve or the condensate line from an air conditioner evaporator coil.
- Slope the condensate drain toward the inside floor drain or condensate pump.
- The condensate drain line and connection to the drain piping must comply with all local codes.
- Do not run the condensate line into the metal drain pan.

## VENT PIPE SYSTEM

### ⚠ WARNING

#### Carbon Monoxide Hazard

Follow all instructions to locate and install the vent pipe system.

Instructions can be found in this manual, in state or local codes (or the authority having jurisdiction), or in the absence of such, the National Fuel Gas Code, ANSI Z223.1, NFPA 54, Current Edition. Canadian installations must be performed in accordance with CAN/CSA-B149.1, Current Edition.

Failure to properly locate and install the vent pipe system can result in death or carbon monoxide poisoning.

## Venting

This water heater has a direct vent system in which all air for combustion is taken from the outside atmosphere and all combustion products are discharged to the outdoors.

This water heater must be properly vented for removal of exhaust gases to the outside atmosphere. Correct installation of the vent pipe system is mandatory for the safe and efficient operation of this water heater and is an important factor in the life of the unit.

Vent pipe installation must be performed in accordance with state and local codes, or in the absence of such, the National Fuel Gas Code, NFPA 54, ANSI Z223.1-current edition. Canadian installations must be performed in accordance with CAN/CSA-B149.1-current edition.

When replacing an existing Polaris® unit, it is recommended that the venting system be reviewed for compliance with the requirements contained in this installation manual. If the venting is not in compliance, it is recommended that the appropriate changes be made to bring it into compliance.

**Note:** It is important that the factory-installed air inlet filter be inspected periodically and cleaned if necessary. See "Integrated Filter Installation, Preventive Maintenance".

**Note:** if the vent system is not in compliance with the current installation manual, the manufacturer reserves the right to evaluate the installation prior to granting any warranty on service claims.

**Important:** Check to make sure the vent pipe is not blocked in any way.

**Note:** Do not common vent this water heater with any other appliance. Do not install in the same chase or chimney with a metal or high-temperature plastic from another gas or fuel burning appliance.

## Integrated Filter Installation

When installing the adaptor rubber boot, note the following:

- Remove and discard the plastic cap from the outer clamshell housing (see figure 4A).
- To connect the heater to the air inlet, use the vent adaptor rubber boot provided in the base skirt. The adaptor rubber boot is designed for 3" venting (see figure 4B). **Note:** If there is a need for 2" venting, then use plastic pipe and fittings to transition down.
- Loosen the hose clamp at the adaptor rubber boot and slide the plastic piping into the adaptor rubber boot. With piping in place, tighten the hose clamp. Install a 3" x 3" x 2" drain/waste/vent fitting to trap airborne particulates (see figure 4C). **Note:** If piping has been previously cut with a saw, be sure to remove all burrs and plastic shavings from the piping before installing.

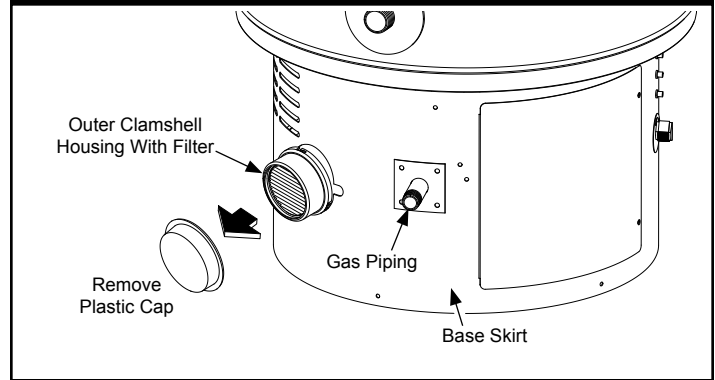
## Preventive Maintenance

The heater is designed to shut down if the pressure switch senses that the air inlet vent or the exhaust vent is restricted. In this case, the pressure switch will open and the heater will generate a 2-flash code (see the troubleshooting section). If troubleshooting section of this manual indicates that there is a blockage, note the following:

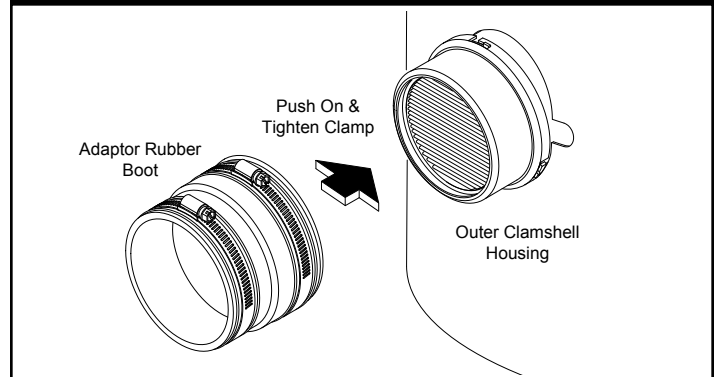
- Turn off the gas supply to the water heater at the manual gas shut-off valve, and disconnect power to the water heater.
- To inspect the filter, loosen the hose clamp at the adaptor rubber boot and slide the plastic pipe out and away from the adaptor rubber boot (see figure 4C).
- Remove the adaptor rubber boot containing the outer clamshell housing by turning clockwise approximately 1/2" (30.5 cm) and pulling off of the internal clamshell housing (see figure 4C).
- Using your fingers or a small flat blade screwdriver, remove the filter media from the outer clamshell housing, handle carefully (see figure 4D).
- To clean filter, lightly tap the back of the filter support to dislodge any large debris. Smaller debris may be removed by using a vacuum cleaner. the filter media may be cleaned by dipping the filter media into a solution of warm soapy water and rinsing in clean water. Do not scrub, allow to air dry before reinstalling. Filter media may be cleaned on an average 2 to 3 times before replacing with a new filter media is required.
- Reinstall the filter media by doing the above steps in reverse order.
- Turn on the gas supply and reconnect power, refer to the operating instructions on front of the water heater. Verify proper operation of the water heater before leaving.

**Note: The heater must never be operated without the filter media installed.**

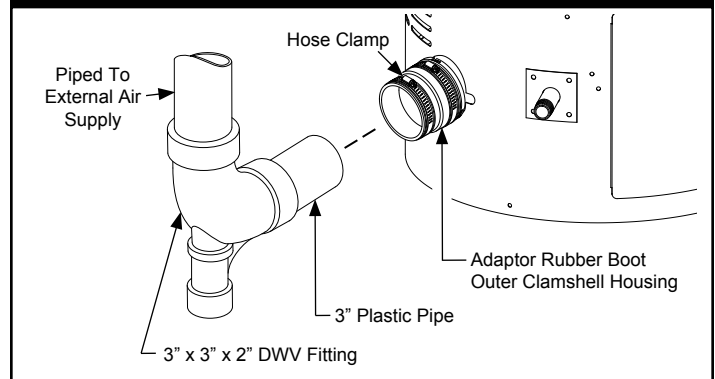
### Figure 4A: Remove Plastic Cap



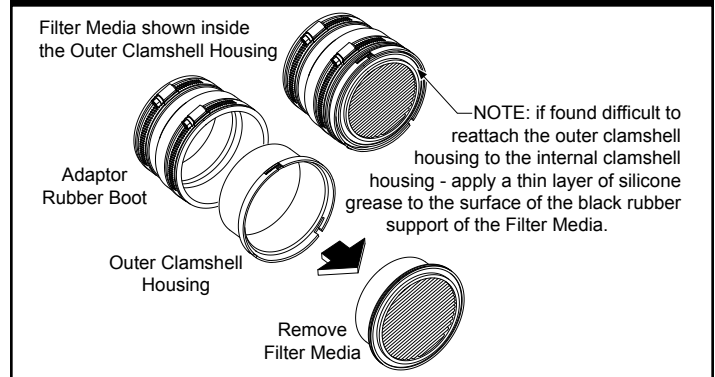
### Figure 4B: Adaptor Rubber Boot



### Figure 4C: Air Inlet Piping



### Figure 4D: Filter Media





# Vent Pipe Material

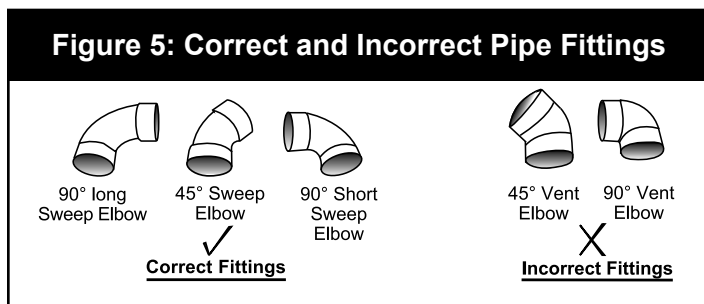
The following plastic materials may be used for both the combustion air inlet and exhaust outlet piping subject to state and local codes:

- Schedule 40 PVC
- Schedule 40 or 80 CPVC
- DWV Pipe is acceptable

**Note:** Use only solid (not foam core) piping.

Plastic pipe and fittings are available through most plumbing suppliers. Always check the marking on the pipe to make sure you are using the correct material.

**Important:** Do not use vent elbows in this vent pipe installation (see figure 5 below).



# Vent Pipe Installation

The following guidelines should be followed when installing the air inlet and exhaust outlet piping:

- Venting should be as direct as possible with a minimum number of pipe fittings.
- Vent diameter must not be reduced unless specifically noted in the installation instructions.
- All 2" horizontal vent piping must be sloped upward 1/4 inch per foot (21 mm per meter); (3" Piping must slope upward at 1/8" per foot) (10.5 mm per meter). This will allow condensate to run back to the heater and exit through the condensate trap.
- Support all horizontal pipe runs every four feet (1.2 m) and all vertical pipe runs every six feet (1.8 m) or according to local codes.
- Vents run through unconditioned spaces where below freezing temperatures are expected should be properly insulated to prevent freezing. Wrap the vent pipe with approved insulation for freeze protection. Install per the manufacturer's instructions.
- An air intake filter is included with the unit and must be installed according to the installation instructions supplied with the filter.

The combustion air inlet and exhaust outlet piping and termination may be installed in one of the following type terminations:

1. Standard Horizontal (2 Pipe)
2. Alternate Horizontal (2 Pipe)
3. Vertical (2 Pipe)
4. Concentric Vent - Through the Wall
5. Concentric Vent - Through the Roof

All pipe, fittings, pipe cement, primers and procedures must conform to American National Standard Institute and American Society for Testing and Materials (ANSI/ASTM) standards in the United States. This water heater has been design certified by the Canadian Standards Association for use with the specified (CSA) listed plastic vent pipe.

All joints in the inlet and outlet piping must be properly cemented. Size and cut all piping before cementing.

1. Cut the pipe end square and remove all ragged edges and burrs. Make sure the inside of the pipe is clean and free of cuttings and loose dirt. Chamfer the end and apply primer to the fitting and pipe.
2. Using a suitable grade of pipe cement, apply a moderate, even coat inside the fitting. Apply a liberal amount of cement to the outside of the pipe to socket depth.

**Note:** It is important to select the proper pipe cement for the type of plastic pipe being used.

3. Assemble the parts quickly while the cement is still wet. Twist the pipe 1/4 turn during insertion and hold for 30 seconds.

# Vent Pipe Length

Size the exhaust outlet and combustion air inlet pipes as specified in Table 1. This table lists the maximum allowable length in feet of the exhaust outlet and combustion air inlet pipes as related to the number of required elbows and the termination. The specified maximum lengths are for the separate inlet and exhaust pipe systems and not the combined length of both systems. Minimum pipe length is 6 feet (1.8 m) with one elbow per side.

1. Determine termination type and pipe size.
2. Determine number of elbows in exhaust pipe. Do not include the elbows in the termination or the condensate trap. Corresponding number indicates the maximum length of exhaust pipe.
3. Determine number of elbows in inlet pipe. Do not include the elbows in the termination. The corresponding number indicates the maximum length of inlet pipe.

Pipe Size in Inches	Number of 90° Elbows (short or long sweep only)						Termination Option	
	0	1	2	3	4	5		6
*2	N/A	52 (15.8)	48 (14.6)	44 (13.4)	40 (12.2)	36 (11)	32 (9.7)	Std. Horizontal
*2	N/A	44 (13.4)	40 (12.2)	36 (11)	32 (9.7)	28 (8.5)	24 (7.3)	Alt. Horizontal
*2	52 (15.8)	48 (14.6)	44 (13.4)	40 (12.2)	36 (11)	32 (9.7)	28 (8.5)	Vertical
*2	N/A	52 (15.8)	48 (14.6)	44 (13.4)	40 (12.2)	36 (11)	32 (9.7)	Concentric
3	N/A	125 (38.1)	120 (36.6)	115 (35)	110 (33.5)	105 (32)	100 (30.5)	Std. Horizontal
3	N/A	115 (35)	110 (33.5)	105 (32)	100 (30.5)	95 (28.9)	90 (27.4)	Alt. Horizontal
3	130 (39.6)	120 (36.6)	115 (35)	110 (33.5)	105 (32)	100 (30.5)	95 (28.9)	Vertical
3	N/A	125 (38.1)	120 (36.6)	115 (35)	110 (33.5)	105 (32)	100 (30.5)	Concentric

**Notes:**

1. N/A - Not Applicable
2. The above maximum lengths are for the separate inlet and outlet pipe systems and not the combined length of both systems.
3. Maximum of 6 elbows may be used per pipe. Use only short or long sweep elbows. See figure 5 for details.
4. Two 45° elbows are considered equivalent to one 90° elbow.
5. Minimum length is 6 feet (1.8 m) per pipe with 1 elbow per side.
6. 2 Inch pipe may be used with 100,000, 130,000 & 150,000 BTU/HR (29.3, 38, & 43.9 kW) input models only.

\* 3" pipe must be used for 175,000 BTU/Hr (51.29 kW) input and above.

# Vent Termination Locations

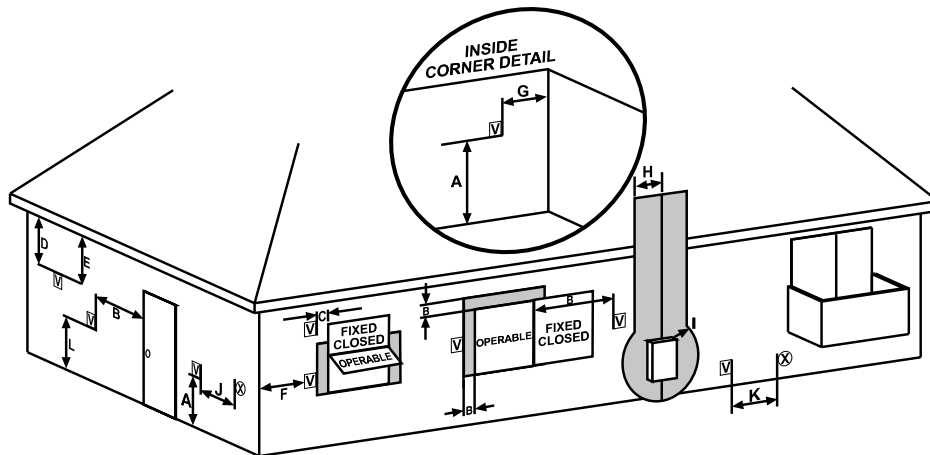
The air inlet and exhaust outlet must be installed with the following minimum clearances (see figure 6):

- Twelve inches (30 cm) above grade or maximum anticipated snow level.
- Twelve inches (30 cm) from any opening through which flue gases could enter the structure.
- Four feet (122 cm) horizontally and vertically from gas or electric meters, gas regulators, dryer vents, vent hoods, bathroom fan exhaust, attic fans and turbines.
- Two feet (61 cm) from an inside corner formed by two exterior walls.
- Two feet from porches, decks, overhangs and other obstructions.

In addition to maintaining the minimum clearances, the vent should terminate according to the following guidelines:

1. Use only 2 inch pipe or a 2 inch concentric vent on the vent termination for 100,000 - 150,000 BTU/Hr models. Do not expose any 3" X 2" reducers or bushings to outdoor ambient temperatures.
2. The air inlet and exhaust outlet must not terminate under a patio, deck or any covered area.
3. Do not terminate the vent near walkways or into alleys or other publicly accessible areas.
4. Combustion air inlet termination and exhaust air termination must be located in the same pressure zone.

**Figure 6: Minimum Clearances for Inlet/Outlet and Concentric Vent**



⊗ Air Supply Inlet    ▮ Vent Terminal    ▨ Area Where Terminal Is Not Permitted

## US Installations

- A.** 12 in (30 cm) min. clearance above grade, veranda, porch, deck, balcony, or maximum anticipated snow level.
- B.** 12 in (30 cm) min. clearance on top and side of window or door that may be opened. Maintain a 36 in (91 cm) minimum clearance below a window or door that may be opened.
- C.** Clearance to permanently closed window.\*\*
- D.** 12 in (30 cm) min vertical clearance to ventilated soffit located above the terminal within a horizontal distance of 2 ft (61 cm) from the center line of the terminal.
- E.** 12 in (30 cm) min. clearance to unventilated soffit.
- F.** Clearance to outside corner \*\*
- G.** 2 ft (61 cm) clearance to inside corner formed by two exterior walls.
- H.** 4 ft (122 cm) clearance to each side of center line extending above meter/regulator assembly.
- I.** 4 ft (122 cm) clearance to service regulator vent outlet.
- J.** 12 in (30 cm) clearance to nonmechanical air supply inlet to building or the combustion air inlet to any other appliance.
- K.** 3 ft (91 cm) above if within 10 ft (3 m) horizontally of mechanical air supply inlet.

## Canadian Installations

- A.** 12 in (30 cm) min. clearance above grade, veranda, porch, deck, balcony, or maximum anticipated snow level.
- B.** 12 in (30 cm) min. clearance on top and side of window or door that may be opened. Maintain a 36 in (91 cm) minimum clearance below a window or door that may be opened.
- C.** Clearance to permanently closed window.\*\*
- D.** 12 in (30 cm) min vertical clearance to ventilated soffit located above the terminal within a horizontal distance of 2 ft (61 cm) from the center line of the terminal.
- E.** 12 in (30 cm) min. clearance to unventilated soffit.
- F.** Clearance to outside corner. \*\*
- G.** 2 ft (61 cm) clearance to inside corner formed by two exterior walls.
- H.** 3 ft (91 cm) within a height 15 ft (4.57 m) above the meter/regulator assembly.
- I.** 4 ft (122 cm) clearance to service regulator vent outlet.
- J.** 12 in (30 cm) clearance to nonmechanical air supply inlet to building or the combustion air inlet to any other appliance.
- K.** 6 ft (1.83 m) clearance to mechanical air supply inlet.

\*\*Clearance in accordance with local installation codes and the requirements of the gas supplier.

# INLET/OUTLET VENT TERMINATIONS

## Standard Horizontal Termination

When 3 inch pipe is used between the water heater and the outside wall, reduce it to 2 inch pipe before penetrating the wall. A maximum of 18 inches (45.7 cm) of 2 inch pipe may be used between the 3 inch transition and the inside of the wall (see figure 7).

The standard horizontal air inlet termination is a 2 inch pipe which terminates at the exterior wall and utilizes a coupling to prevent the pipe from being pushed back into the structure. The standard horizontal exhaust outlet termination is a 2 inch pipe which terminates 12 inches (30.5 cm) from the outside wall. The air inlet must be located with respect to the exhaust outlet as shown in figure 7 (bottom).

Install a drain tee assembly and trap in the inlet vent as close to the water heater as possible. This is to drain any water that may be in the combustion air pipe and prevent it from entering the blower. Connect the trap drain line to a suitable drain or downstream of the condensate trap of the water heater.

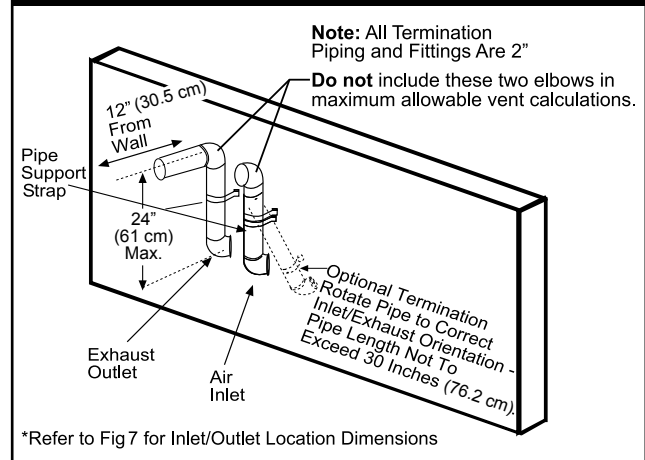
**Note:** See "Venting Additional Polaris® Units" on Page 12 for correct terminations if installing more than one Polaris® gas water heater.

## Alternative Horizontal Termination

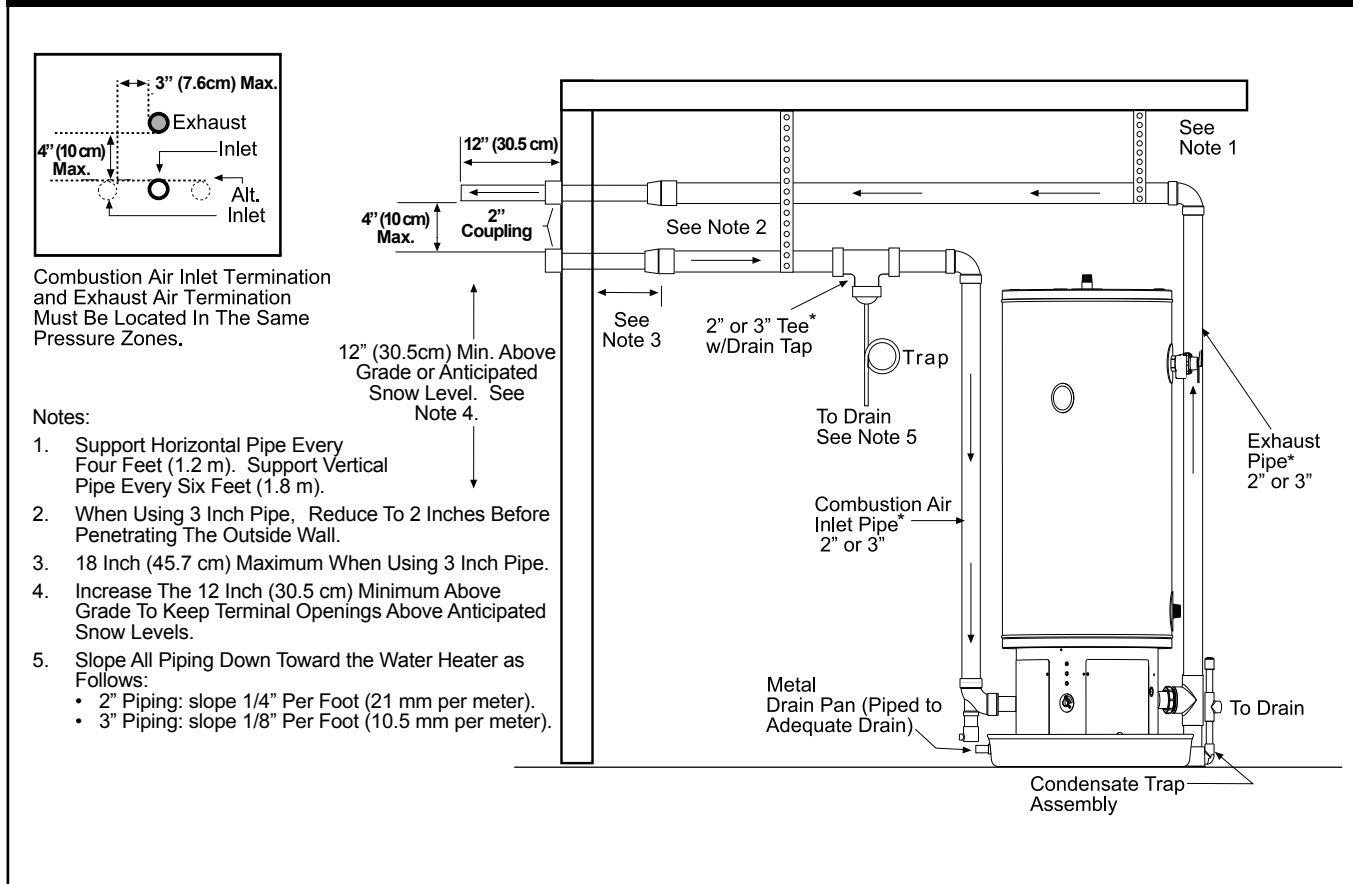
The combustion air and exhaust terminations may be raised up to 24 inches (61 cm) above the wall penetrations if required for anticipated snow levels (see figure 8). The two elbows shown in figure 8 are considered part of the termination and should not be included when determining the maximum allowable vent pipe length.

**Note:** See "Venting Additional Polaris® Units" on Page 12 for correct terminations if installing more than one Polaris® gas water heater.

**Figure 8: Alternate Horizontal Termination**



**Figure 7: Standard Horizontal Termination**



# VERTICAL TERMINATIONS

When 3 inch pipe is used between the water heater and the roof, reduce it to 2 inch pipe before penetrating the roof. A maximum of 18 inches (45.7 cm) of 2 inch pipe may be used between the 3 inch transition and the inside of the roof.

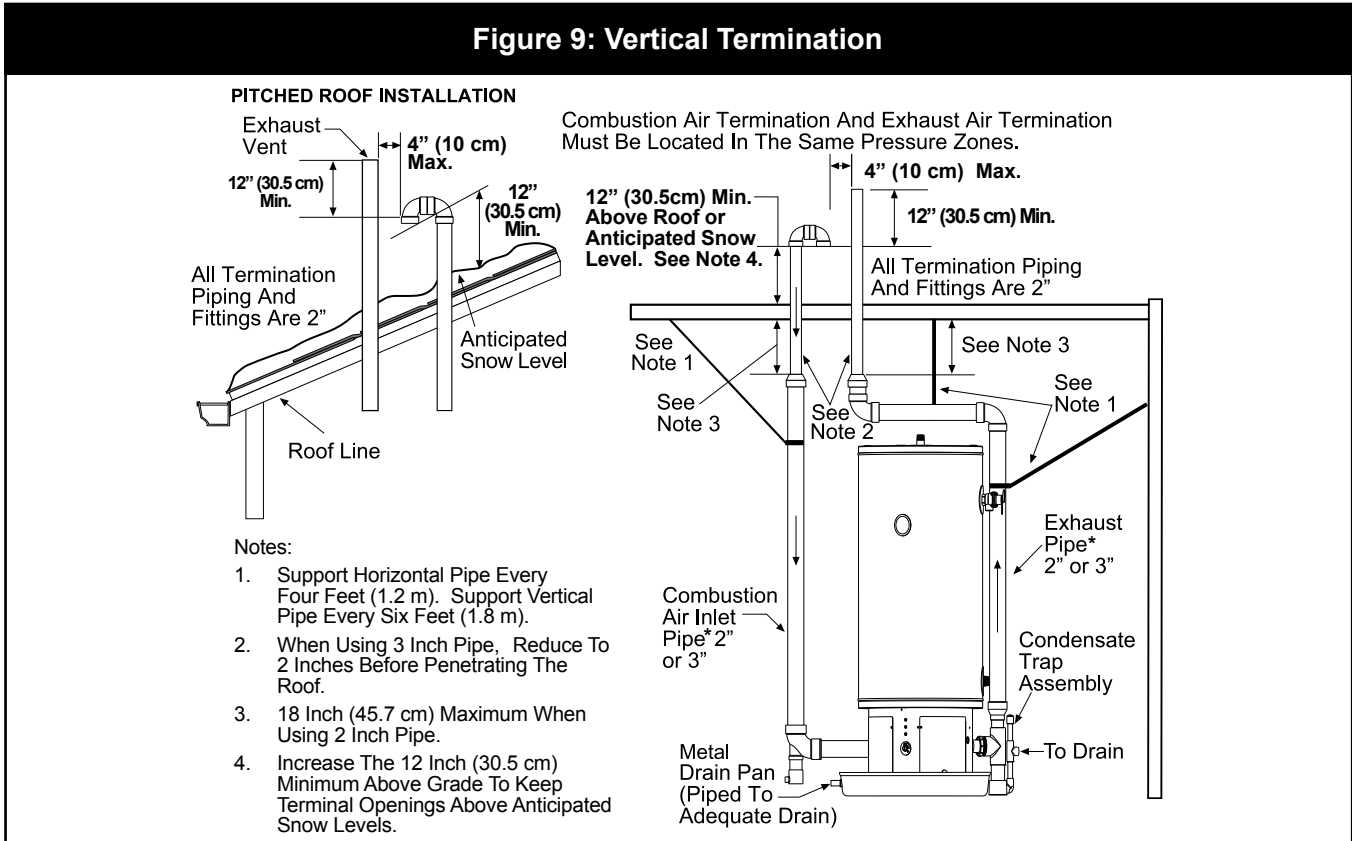
The vertical inlet air termination requires a return bend or two short or long sweep radius 90 elbows to keep the inlet downward and prevent entry of rain. These elbows are considered part of the termination and should not be included when calculating the maximum allowable vent pipe length. Refer to figure 9 for the proper location of the air inlet with respect to the exhaust outlet termination. The vertical exhaust outlet termination is a 2 inch (30.5 cm) pipe

which terminates at least 12 inches (30.5 cm) above the inlet air termination.

The air inlet and exhaust outlet terminations must be at least 12 inches (30.5 cm) above the roof line or anticipated snow levels. See figure 9 below.

**Note:** See "Venting Additional Polaris® Units" below if installing more than one Polaris® gas water heater.

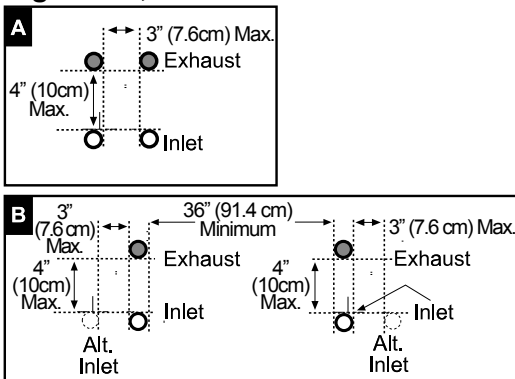
**Figure 9: Vertical Termination**



## Venting Additional Polaris® Units

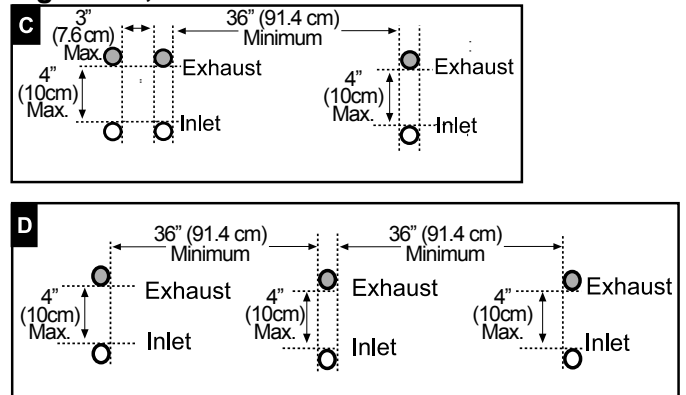
When using two (2) Polaris® units, install vent terminations using either Method A or Method B below:

**Figure 9A, 9B**



When using three or more Polaris® units, install vent terminations per Method C or Method D:

**Figure 9C, 9D**



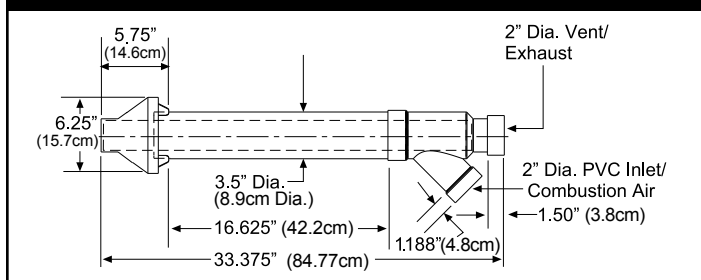
# CONCENTRIC VENT TERMINATIONS

For new installations, install 2" Concentric vent kit model KGAVT0501CVT, part number 6910542. See Manufacturer's instructions for complete installation or call customer service at 1-800-456-9805 for assistance or go to [www.americanwaterheater.com](http://www.americanwaterheater.com).

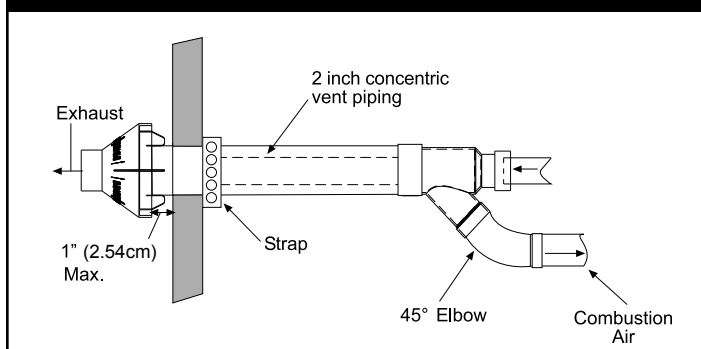
For planning purposes, see figures 10-13 below for vent terminal specifications.

**Note:** For replacement installations, previously installed American Water Heater Company supplied concentric vent kits are acceptable for use on 100,000-130,000 BTU/Hr models only. Make sure that the existing vent complies with current codes.

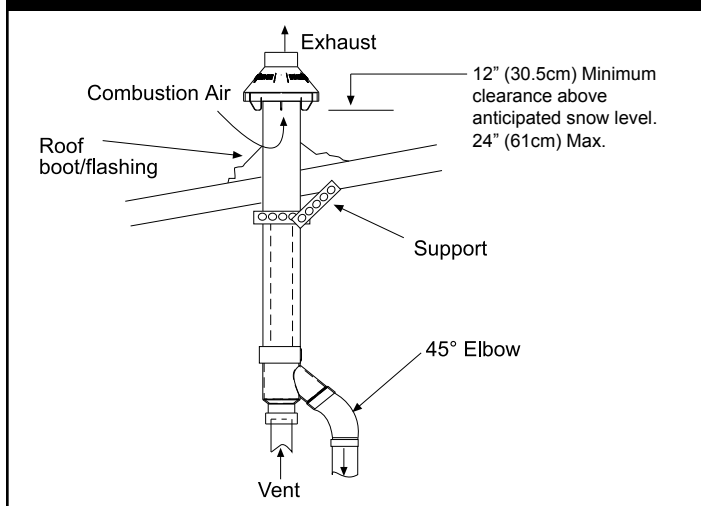
**Figure 10: 2 Inch Concentric Vent**



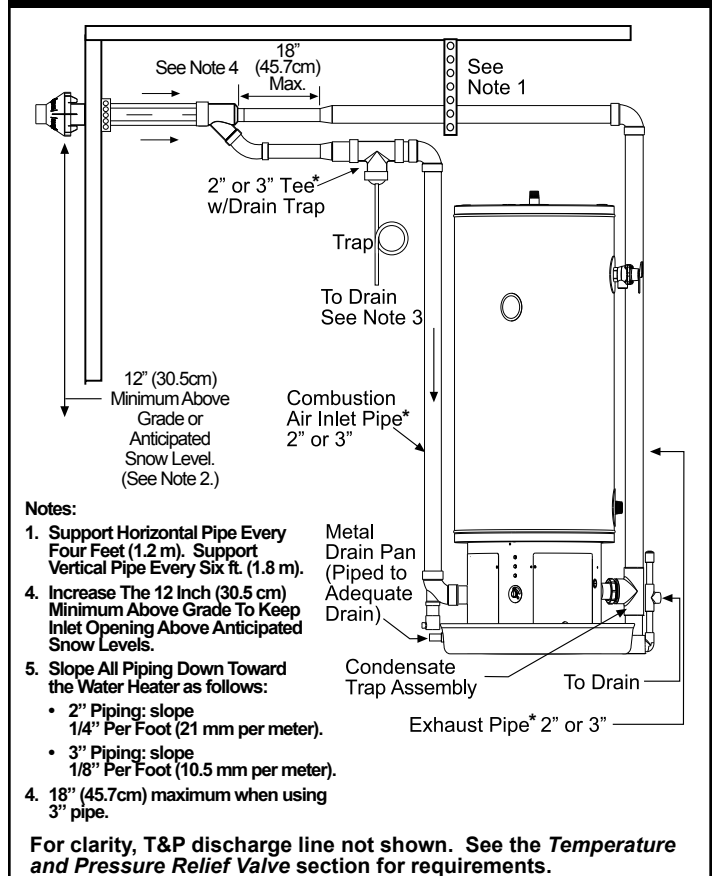
**Figure 11: Through the Wall Termination**



**Figure 12: Through the Roof Termination**

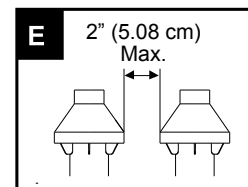


**Figure 13: Through the Wall Termination**

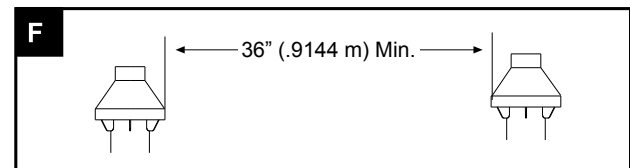


## Concentric Venting Multiple Water Heaters (All Models)

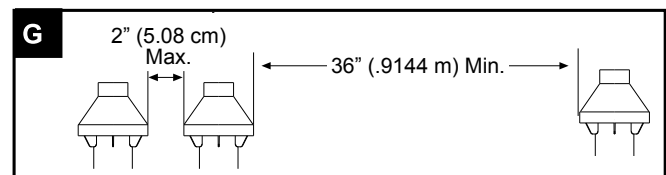
When using two Polaris® units, install vent terminations using either Method E or Method F below:



**Figure 13E, 13F, 13G**



**Note:** For installation of more than two Polaris® units, follow the pattern established in Method G.



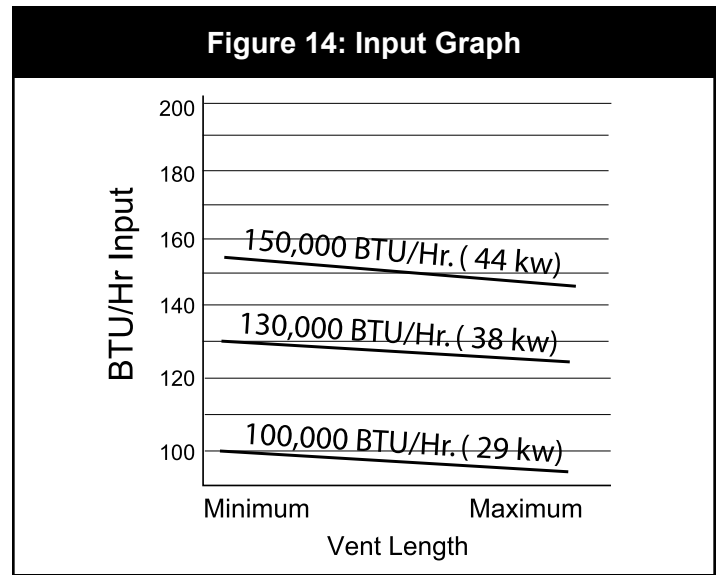
## Gas Input Rate

The gas input rate of this water heater is affected by several environmental factors such as:

- The heating value of the gas
- The air and gas densities (which vary widely due to barometric pressure and temperature changes)
- Venting installations (pipe diameter, length and fittings)
- Altitude

When measuring the input rate these factors should be incorporated into the calculations. Also measure the gas consumption over a sufficiently long time to obtain an accurate gas consumption rate (e.g. 3-5 minutes, not one revolution of the meter needle).

Long vents and each additional elbow, inherently reduce the gas input rate due to increased resistance to moving combustion air and flue gases. The approximate maximum/minimum input for the 100k, 130k, and 150k models is shown in figure 15.



## WATER PIPING SYSTEM

### Piping Installation

Piping, fittings, and valves should be installed according to the installation drawing (figure 15). If the indoor installation area is subject to freezing temperatures, the water piping must be protected by insulation.

The water supply pressure should not exceed 80 psi (551.5 kPa). If this occurs, a pressure reducing valve with a bypass should be installed in the cold water inlet line. This should be placed on the supply to the entire house in order to maintain equal hot and cold water pressures.

**Important: Heat cannot be applied to the water fittings on the heater as they may contain nonmetallic parts. If solder connections are used, solder the pipe to the adapter before attaching the adapter to the hot and cold water fittings.**

**Important: Do not install this water heater with iron or galvanized piping. Use brass caps on all unused inlet/outlet connections.**

1. Install the water piping and fittings as shown in figure 15. Note: If state or local codes require, install a vacuum relief valve per the manufactures instructions in the cold water supply line. Connect the cold water supply (use 1" NPT) to the fitting marked "COLD INLET". Do not turn the cold water nipple. The mark should remain along the top side of the nipple. Connect the hot water supply (use 1" NPT) to the fitting marked "HOT OUTLET".
2. Always use a suitable grade of joint compound and be certain that all fittings are tightened properly.
3. The installation of unions in both the hot and cold water supply lines is recommended for ease of removing the water heater for service or replacement.
4. If installing the water heater in a closed water system, install an expansion tank in the cold water line as specified under "Closed System/Thermal Expansion" (Page 15).
5. Install a shut-off valve in the cold water inlet line. It should be located close to the water heater and be easily accessible. Know the location of this valve and how to shut off the water to the heater.

6. The Polaris® gas water heater is shipped with a factory-installed Temperature and Pressure Relief Valve. Install a discharge line in the opening in the T & P valve (see instructions on Page 17).
7. After piping has been properly connected to the water heater, remove the aerator at the nearest hot water faucet. Open the hot water faucet and allow the tank to completely fill with water. **(To prevent damage to the unit, DO NOT connect power until the tank is COMPLETELY FILLED).** To purge the lines of any excess air, keep the hot water faucet open for 3 minutes after a constant flow of water is obtained. Close the faucet and check all connections for leaks.

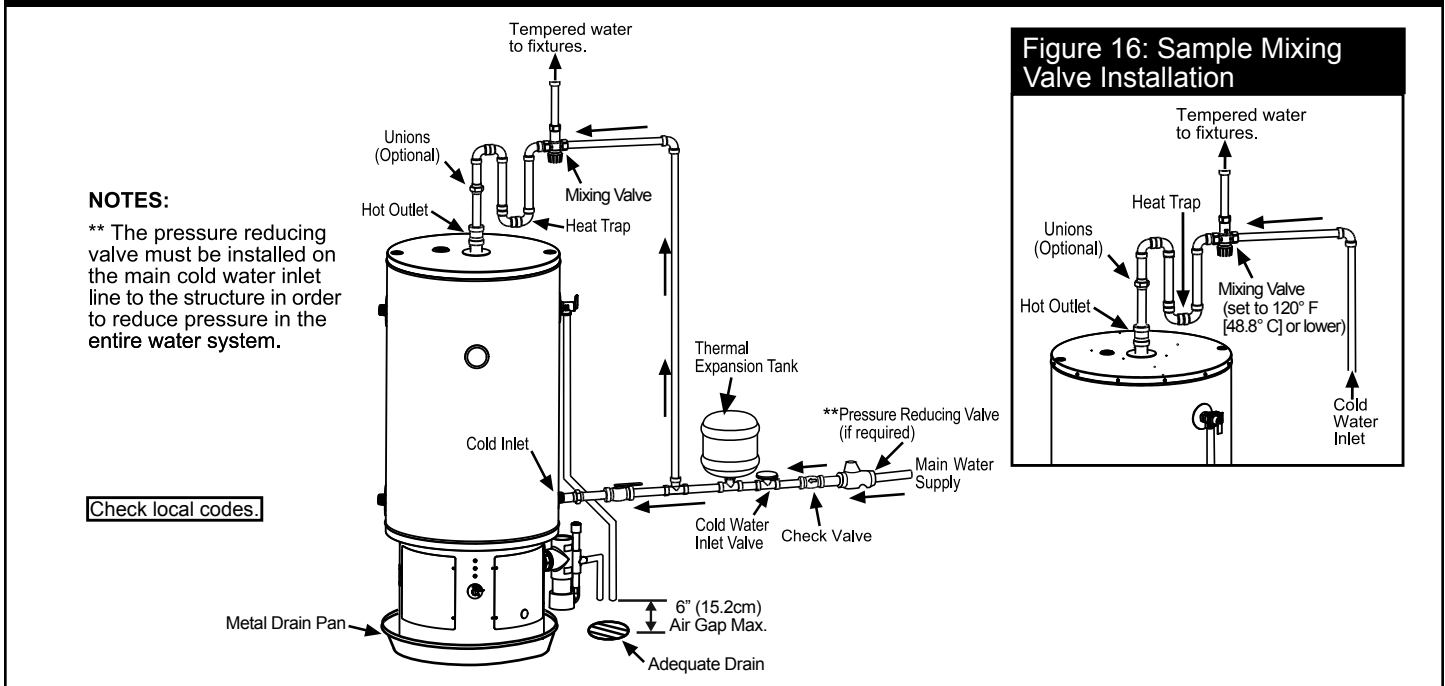
### Corrosion and Water Quality

Water quality will vary from location to location and may contain contaminates that may reduce the life or performance of the water heater. To test for contaminates a water quality test kit is available, reference part number 6903791.

Contaminates which can reduce the life or performance of the water heater if present in high quantities include those which contribute to hardness (dissolved minerals such as sodium, calcium and magnesium); plus chlorides and sulfates. Additionally, water that is too acidic or basic (measured as pH) can reduce the life of the water heater. Water treatment systems (such as water softeners for hardness) should be used and maintained properly if the contaminate levels exceed the following:  
**Warranty is void in applications which exceed the water quality requirements listed below.**

Total Hardness:	12 grains per gal. (205 mg/liter) max.
Chloride:	200 mg/liter max.
pH:	6.5-8.0
Alkalinity:	200 mg/liter max.

**Figure 15: Typical One-Temperature System Piping Installation**

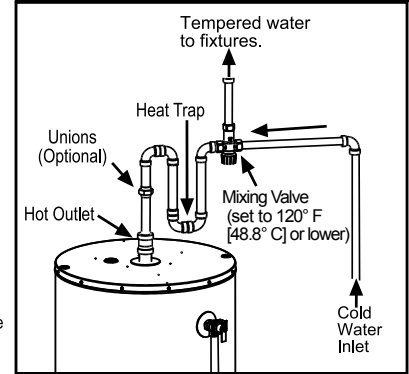


**NOTES:**

\*\* The pressure reducing valve must be installed on the main cold water inlet line to the structure in order to reduce pressure in the entire water system.

Check local codes.

**Figure 16: Sample Mixing Valve Installation**



**Mixing Valve Installation**

A mixing valve has been provided for use with the Polaris® Gas water heater and must be installed, per the manufacturer’s instructions, in the domestic hot water line. See Figure 16 for a sample tempering valve installation.

**General Information**

Water piping, fittings, and valves must be properly installed for the correct and safe operation of this water heater. Please note the following:

- The system should be installed only with piping that is suitable for potable (drinking) water such as copper, CPVC, PEX or polybutylene. PVC water piping may be used on the cold water inlet supply but not within 18 inches (45.7 cm) of the cold water connection on the water heater.
- Do not use PVC piping on the hot water outlet, space heating supply, or space heating return.
- Do not use any pumps, valves, or fittings that are not compatible with potable water.
- Do not use valves that may cause excessive restriction to water flow. Use full flow ball or gate valves only.
- Do not use 50/50 tin-lead solder (or any lead based solder) in potable water lines. Use 95/5 solder or other equivalent material.
- Do not tamper with the thermostat, gas valve, blower, electrical components, or temperature and pressure relief valve. Tampering with any of the components is dangerous and can result in death, severe injury, or property damage. Tampering voids all warranties. Only qualified technicians should service these components.
- Do not use this water heater as a replacement for an existing boiler installation.
- Do not use with piping that has been treated with chromates, boiler seal, or other chemicals.
- Do not add any chemicals to the system piping which will contaminate the potable water supply.

**Closed System/Thermal Expansion**

As water is heated, it expands (thermal expansion). In a closed system, the volume of water will increase. As the volume of water increases, there will be a corresponding increase in water pressure due to thermal expansion. Thermal expansion can cause premature tank failure (leakage). This type of failure is not covered under the limited warranty. Thermal expansion can also cause intermittent temperature-pressure relief valve operation; water discharged from the valve due to excessive pressure build up. The temperature-pressure relief valve is not intended for the constant relief of thermal expansion. This condition is not covered under the limited warranty.

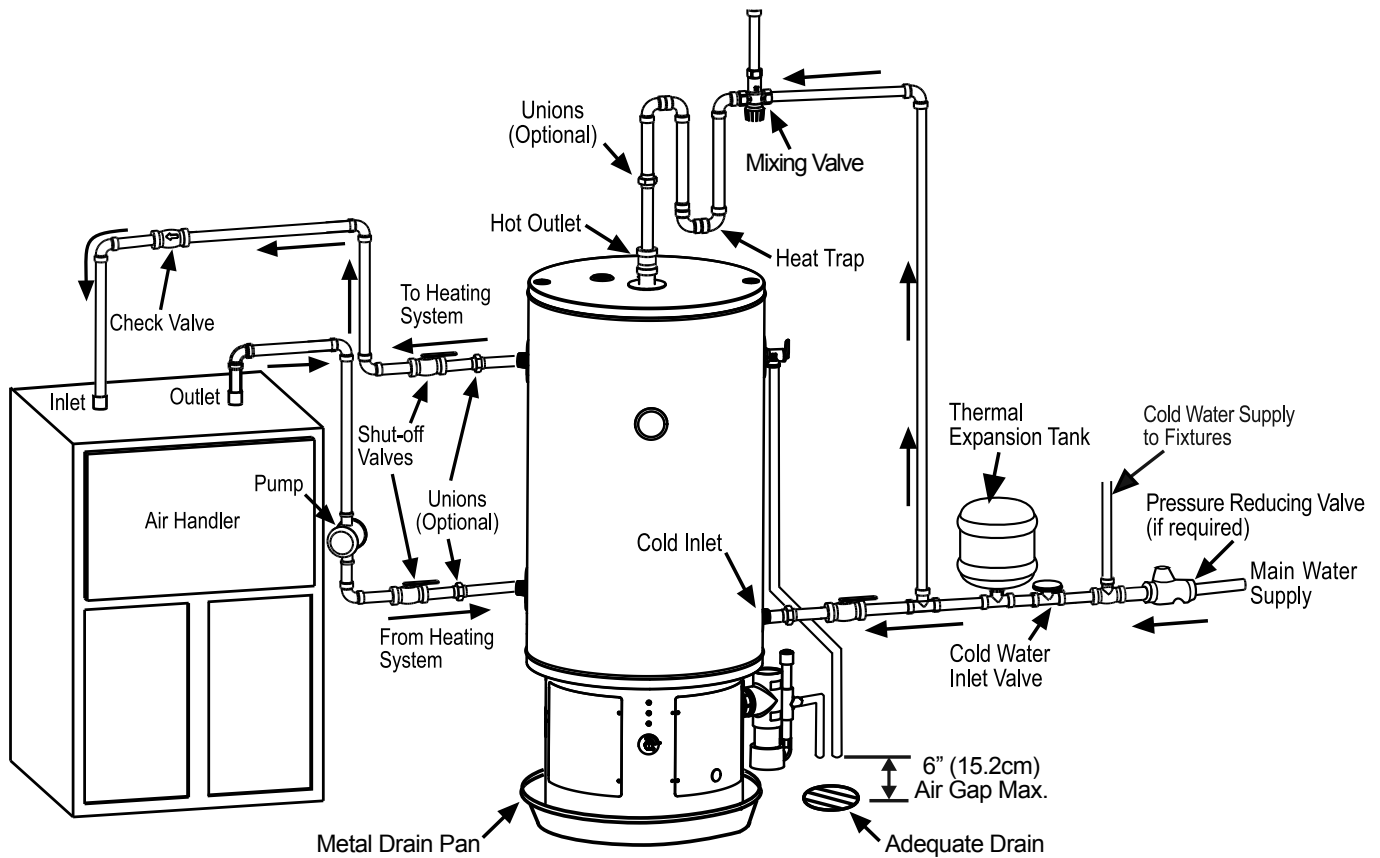
A properly-sized thermal expansion tank should be installed on all closed systems to control the harmful effects of thermal expansion. Contact a plumbing service agency or your retail supplier regarding the installation of a thermal expansion tank. **The manufacturer of this water heater will void the warranty if there is a failure to install a properly sized expansion tank.**

**Combination Space Heating/Potable Water System**

Some water heater models are equipped with inlet/outlet connections for use in space heating applications. **Note:** this water heater, “Suitable for combination water (potable) heating and space heating and not suitable for space heating applications only.” If this water heater is to be used to supply both space heating and potable (drinking) water, the instructions listed below must be followed (see figure 17).

- Be sure to follow the manual(s) shipped with the air handler or other type heating system.
- This water heater is not to be used as a replacement for an existing boiler installation.

**Figure 17: Air Handler Piping Installation**



**Massachusetts code does not allow this type of installation.**

- Do not use with piping that has been treated with chromates, boiler seal or other chemicals and do not add any chemicals to the water heater piping.
- If the space heating system requires water temperatures in excess of 120°F (48.9°C), a mixing valve (provided) must be installed per the manufacturer's instructions in the potable hot water supply to limit the risk of scald injury.
- Pumps, valves, piping and fittings must be compatible with potable water.
- A properly installed flow control valve is required to prevent thermosiphoning. Thermosiphoning is the result of a continuous flow of water through the air handler circuit during the off cycle. Weeping (blow off) of the temperature and pressure relief valve (T & P) or higher than normal water temperatures are the first signs of thermosiphoning.
- The hot water line from the water heater should be vertical past any mixing valve or supply line to the heating system to remove air bubbles from the system.
- Do not connect the water heater to any system or components previously used with non-potable water heating appliances when used to supply potable water.

## Storage Tank Installation

When installing the Polaris® with a storage tank, see figure 18 for piping suggestions.

## Solar Installation

If this water heater is used as a solar storage heater or as a backup for the solar system, the water supply temperatures to the water heater tank may be in excess of 120°F (48.9°C). A mixing valve must be installed in the water supply line to limit the supply temperature to 120°F (48.9°C).

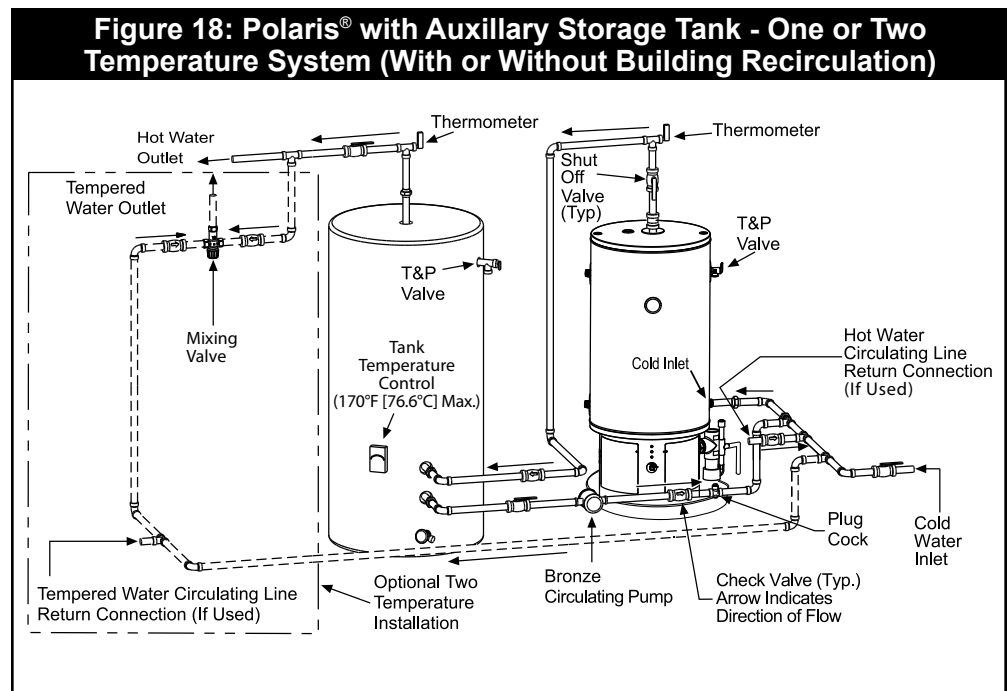
**Note:** Solar water heating systems can often supply water with temperatures exceeding 180°F (82.2°C) and may result in water heater malfunction.



## Notes on Figure 18:

If tank temperature is set above 120°F (48.9°C) and water is supplied for domestic use (hand washing, showering, etc.) a mixing valve must be installed in the hot water line to domestic fixtures.

Installation must conform to local code requirements. If a check valve is installed in the cold water supply line, an expansion tank must be installed between the check valve and the water heater's cold water inlet. Set storage tank temperature five degrees lower than the water heater's temperature setting. Using the plug valve in the recirculating line, adjust the flow in the recirculating line to five gallons per minute.



## Temperature and Pressure Relief Valve

**⚠ WARNING**



### Explosion Hazard

- **Temperature-pressure relief valve must comply with ANSI Z21.22-CSA 4.4 and ASME code.**
- **A properly-sized temperature-pressure relief valve must be installed in the opening provided.**
- **Do not plug, block, or cap the discharge line.**
- **Failure to follow this warning can result in excessive tank pressure, serious injury or death.**

For protection against excessive pressures and temperatures, a temperature and pressure relief valve must be installed in the opening marked "T & P RELIEF VALVE". This valve must be design certified by a nationally recognized testing laboratory that maintains periodic inspection of the production of listed equipment or materials as meeting the requirements for Relief Valves and Automatic Shut-

off Devices for Hot Water Supply Systems, ANSI Z21.22. The function of the temperature and pressure relief valve is to discharge water in large quantities in the event of excessive temperature or pressure developing in the water heater. The valve's relief pressure must not exceed the working pressure of the water heater as stated on the data plate.

**Important:** Only a new temperature and pressure relief valve should be used with this water heater. Do not use an old or existing valve as it may be damaged or not adequate for the working pressure of the new water heater. Do not place any valve or piping between the relief valve and the tank.

The Temperature & Pressure Relief Valve:

- Must not be in contact with any electrical part.
- Must be connected to an adequate discharge line.
- Must not be rated higher than the working pressure shown on the data plate of the water heater.
- The BTUH rating of the T & P valve must be greater than, or equal to, the input rating of the water heater

The Discharge Line:

- Must not be smaller than the pipe size of the relief valve or have any reducing coupling installed in the discharge line.
- Must not be capped, blocked, plugged or contain any valve between the relief valve and the end of the discharge line.
- Must terminate a maximum of 6 inches (15.2 cm) above a floor drain or external to the building.
- Must be capable of withstanding 250°F (121°C) without distortion.
- Must be installed to allow complete drainage of both the valve and discharge line.

# GAS SUPPLY AND PIPING

## ⚠️ WARNING



### Explosion Hazard

Use a new AGA or CSA approved gas supply line.

Install a shut-off valve.

Do not connect a natural gas water heater to a L.P. Gas Supply.

Do not connect an L.P. gas water heater to a Natural Gas Supply.

Failure to follow these instructions can result in death, explosion, or carbon monoxide poisoning.

## Gas Requirements

Read the data plate to be sure the water heater is made for the type of gas being used. This information will be found on the data plate located on the front of the water heater. If the information does not agree with the type of gas available, do not install or operate the water heater. Call your dealer.

**Note:** An odorant may be added by the gas supplier to the gas used by this water heater. This odorant may fade over an extended period of time. Do not depend upon this odorant as an indication of leaking gas.

## Gas Piping

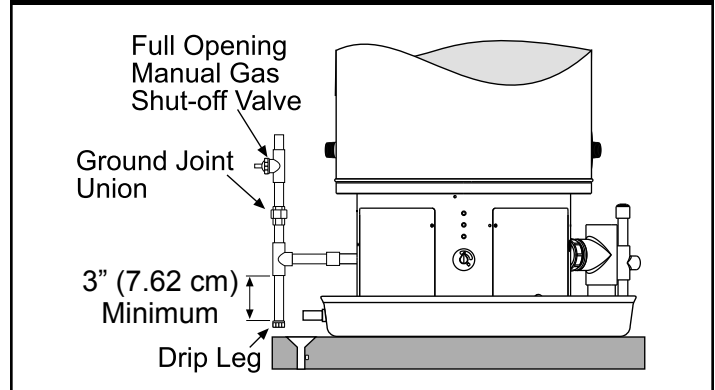
The gas piping must be installed according to all local and state codes or in absence of local and state codes with the "National Fuel Gas Code", ANSI Z223.1 (NFPA 54)-current edition. Canadian installations must be performed in accordance with CAN/CSA-B149.1-current edition.

**Note:** If using a flexible gas connector, make sure its rating tag matches or exceeds the input of the water heater.

Follow the instructions below and reference figure 19 for gas piping installation.

1. Install a readily accessible manual shut-off valve in the gas supply line as recommended by the local utility. Know the location of this valve and how to turn off the gas to this unit.
2. Install a drip leg as shown. The drip leg must be no less than 3 inches (7.62 cm) long for the accumulation of dirt, foreign material and water droplets.
3. Install a ground joint union between the water heater and the manual shut-off valve. This is to allow easy servicing.
4. Turn the gas supply on and check for leaks. Use a chloride-free soap and water solution (bubbles forming indicate a leak) or other approved method.

Figure 19: Gas Piping Installation



## Gas Pressure

**Important:** The gas supply pressure must not exceed the maximum supply pressure as stated on the water heater's data plate. Minimum supply pressure should also be maintained per the data plate.



## Gas Pressure Testing

**Important:** This water heater and its gas connection must be leak tested before placing the appliance in operation.

- If the code requires the gas lines to be tested **at** a pressure of 14" W.C. (3.486 kPa) or greater, the water heater and its manual shut-off valve must be **disconnected** from the gas supply piping system and the line capped.
- If the gas lines are to be tested at a pressure **less than** 14" W.C. (3.486 kPa), the water heater must be **isolated** from the gas supply piping system by closing its manual shut-off valve.

Nationally listed/recognized fuel gas and carbon monoxide(CO) detectors are recommended in all applications and should be installed using the manufacturer's instructions and local codes, rules, or regulations.

**Note:** Air may be present in the gas lines and could prevent the burner from lighting on initial start-up. The gas lines should be purged of air by a qualified service technician after installation of the gas piping system.

 <b>WARNING</b>

<b>Explosion Hazard</b> <b>Have a qualified person make sure that the L.P. gas operating pressure does not exceed 13" water column (3.237 kPa). Examples of a qualified person include licensed heating personnel, authorized gas company personnel, and authorized service personnel.</b> <b>Failure to do so can result in death, explosion, or fire.</b>

# ELECTRICAL CONNECTIONS

## ⚠️ WARNING



**Electrical Shock Hazard**  
**Disconnect power before servicing.**  
**Replace all parts and panels before operating.**  
**Failure to do so can result in death or electrical shock.**

If you lack the necessary skills required to properly install the electrical wiring to this water heater, do not proceed but have a qualified electrician perform the installation.

When making the electrical connections, always make sure:

- The voltage and frequency correspond to that specified on the water heater data plate on the front of the water heater.
- The electrical supply has the proper overload fuse or breaker protection. The heater draws less than 7 amps.
- Wire sizes and connections comply with all applicable codes.
- Wiring enclosed in approved conduit (if required by local codes).
- The water heater and electrical supply are properly grounded.
- This water heater must be "hard-wired" - do not use an extension cord to supply electrical power to this water heater.

### Note:

The wiring diagram can be found on Page 21. Always reference the wiring diagram(s) for the correct electrical connections.

When installing the electrical wiring to the water heater:

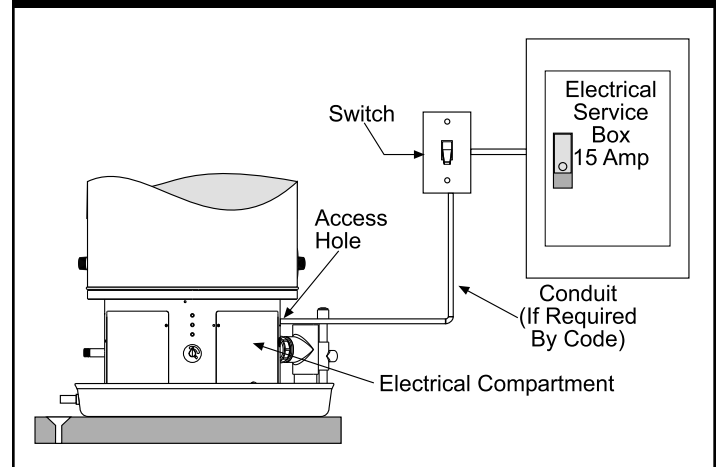
1. Shut off the power at the electrical service box.
2. Loosen the screws securing the access panel to the electrical compartment. (The electrical wiring diagram, models can be found on the inside of the access panel at the base of the water heater.) Set the access panel aside.
3. Connect the electrical supply to the water heater in accordance with local utility requirements and codes. Use only a dedicated electrical circuit containing a properly sized fuse or circuit breaker. Maximum overload protection should not exceed 15 amperes.

4. Connect this circuit (directly from the electrical service box) to an electrical disconnect switch.
5. Ground the water heater by connecting the electrical service ground wire to the green ground wire (provided).

**Note:** The power supply to this water heater must be properly polarized, [120 volts from the hot lead (black) to ground and 0 volts from the neutral lead (white) to ground] otherwise, the unit will not operate.

6. After making all electrical connections, completely fill the tank with water and check all connections for leaks. Open the nearest hot water faucet and let it run for 3 minutes to purge the water lines of air and sediment and to ensure complete filling of the tank. The electrical power may then be turned on. See figure 20 for completed installation.

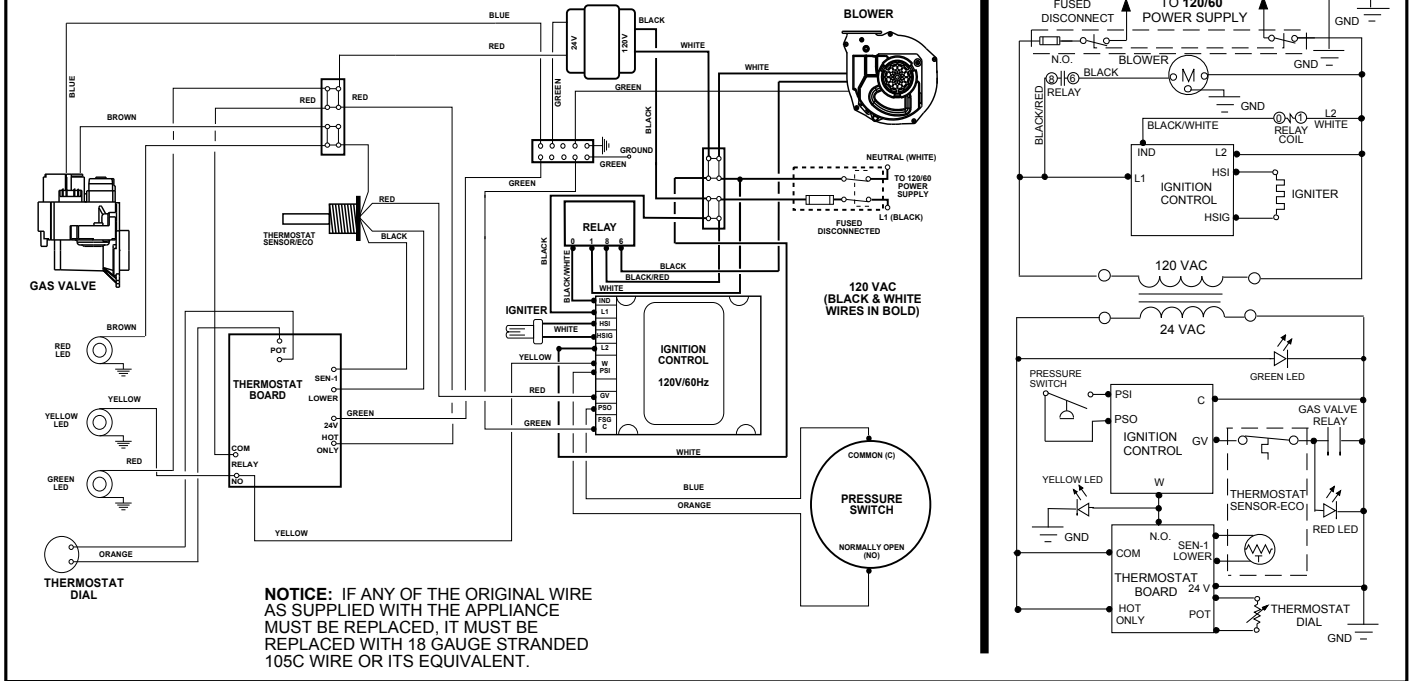
**Figure 20: Electrical Connections**



# WIRING DIAGRAM

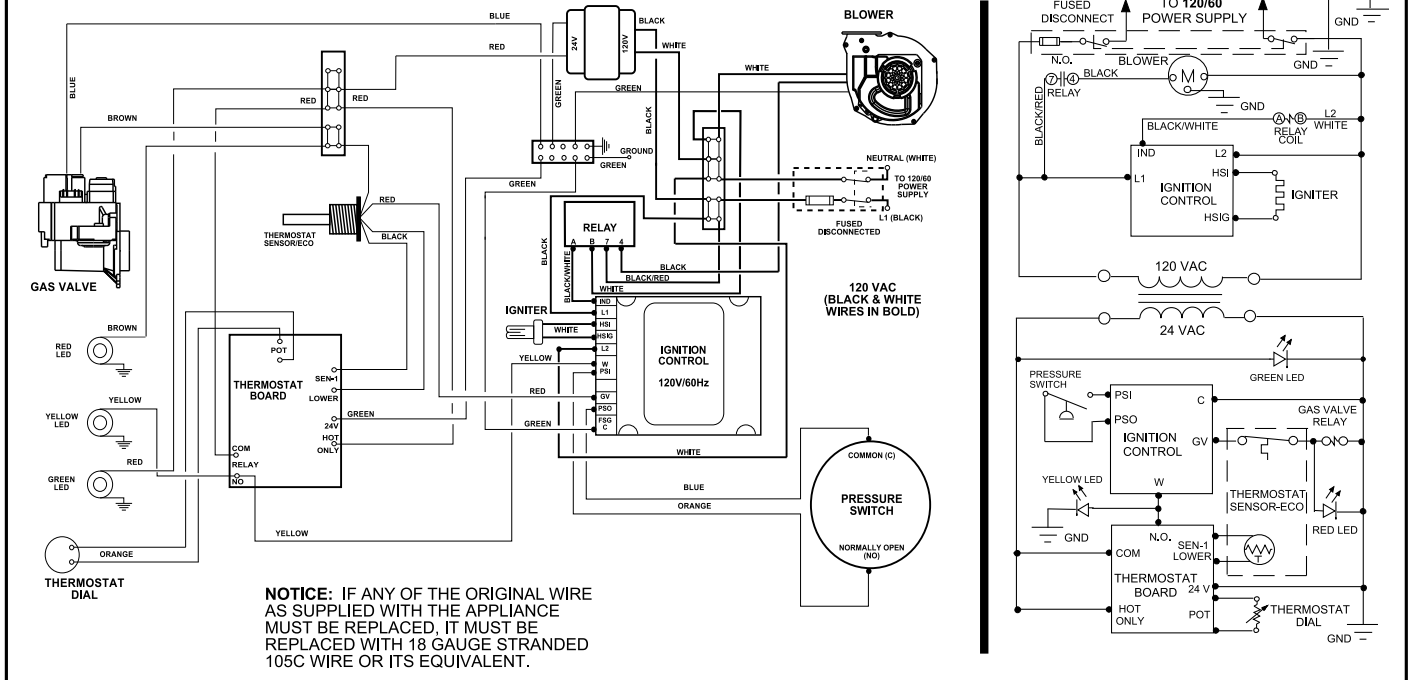
## HEATER SUPPLIED WITH T92 SERIES RELAY

Figure 20A



## HEATER SUPPLIED WITH KUHP SERIES RELAY

Figure 20B



# INSTALLATION CHECKLIST

## Water Heater Location Requirements

- Centrally located with the water piping system. Located as close to the gas piping and vent pipe system as possible.
- Located indoors and in a vertical position. Protected from freezing temperatures.
- Proper clearances from combustible surfaces maintained and not installed directly on a carpeted floor. Sufficient room to service the water heater.
- Provisions made to protect the area from water damage. Properly sized metal drain pan installed and piped to an adequate drain.
- Installation area free of corrosive elements and flammable materials.

## Condensate Line

- Drain stem is fully inserted in the elbow and glued properly.
- Trap aligned so that the exhaust pipe is in a vertical position close to the surface of the water heater.
- Line properly sloped to adequate drain or approved condensate pump.
- Properly vented.
- Protected from freezing (if required).

## Vent Pipe System

- Vent pipe and fittings of approved material.
- Acceptable size, length, and number of elbows on air inlet pipe.
- Acceptable size, length, and number of elbows on exhaust outlet pipe.
- Add the air inlet filter per the manufacturer's instruction.
- Installed in accordance with prevailing provisions of Local codes, or in the absence of such, National Fuel Gas Code, NFPA 54, ANSI Z223.1-Current Edition. Canadian Installations must be performed in accordance with CAN/CSA-B149.1-Current Edition.
- All 2" horizontal piping sloped down toward the water heater at 1/4" per foot (21 mm per meter). 3" piping sloped down towards the heater at 1/8" per foot (10.5 mm per meter).
- Not obstructed in any way.

## Vent Termination

### *Horizontal*

- Correct relationship - outlet to inlet.
- 12" Min. (30.5 cm) above grade/snow level.
- 2" exhaust outlet/air inlet pipe sloped down towards water heater at 1/4" per foot (21 mm per meter). 3" piping sloped down towards the heater at 1/8" per foot (10.5 mm per meter).
- Away from corners, other vents, windows, etc.

### *Alternate Horizontal*

- Correct relationship - outlet to inlet.
- 12" Min. (30.5 cm) above anticipated snow level.
- 2" exhaust outlet/air inlet pipe sloped down towards water heater at 1/4" per foot (21 mm per meter). 3" piping sloped down towards the heater at 1/8" per foot (10.5 mm per meter).
- Away from corners, other vents, windows, etc.

### *Vertical*

- Inlet - 12" Min. (30.5 cm) above roof/snow level.
- Correct relationship - outlet to inlet.
- Away from corners, other vents, windows, etc.

### *Concentric*

- 12" Min. (30.5 cm) above grade/snow level.
- 2" exhaust outlet/air inlet pipe sloped down towards water heater at 1/4" per foot (21 mm per meter). 3" piping sloped down towards the heater at 1/8" per foot (10.5 mm per meter).
- Away from corners, other vents, windows, etc.

## Water System Piping

- Temperature and pressure relief valve properly installed with a discharge line run to an open drain and protected from freezing.
- All piping properly installed and free of leaks.
- Heater completely filled with water.
- A properly sized expansion tank must be installed on all closed systems.
- A mixing valve must be installed per the manufacturer's instructions.

## Gas Supply and Piping

- If using a flexible gas connector, make sure its rating tag matches or exceeds the input of the water heater.
- Adequate pipe size and of approved material.
- Gas supply is the same type as listed on the water heater data plate.
- Gas line equipped with full opening shut-off valve, union and drip leg.
- Approved pipe joint compound used.
- Chloride-free soap and water solution or other approved means used to check all connections and fittings for possible gas leaks.

## Electrical Connections

- Unit connected to a dedicated power supply.
- Unit connected to a 120V electrical supply.
- Proper polarity.
- Water heater properly grounded.
- Installed in accordance with prevailing provisions of local codes, or in the absence of such, National Fuel Gas Code, NFPA 54, ANSI Z223.1-Current Edition. Canadian installations must be performed in accordance with CAN/CSA-B149.1-Current Edition.

# OPERATING YOUR WATER HEATER

Read and understand these directions thoroughly before attempting to operate the water heater (see Operating Instructions on Page 24). Check the data plate on the front of the water heater for the correct gas. Do not use this water heater with any gas other than the one listed on the data plate. If you have any questions or doubts, consult your gas supplier or gas utility company.

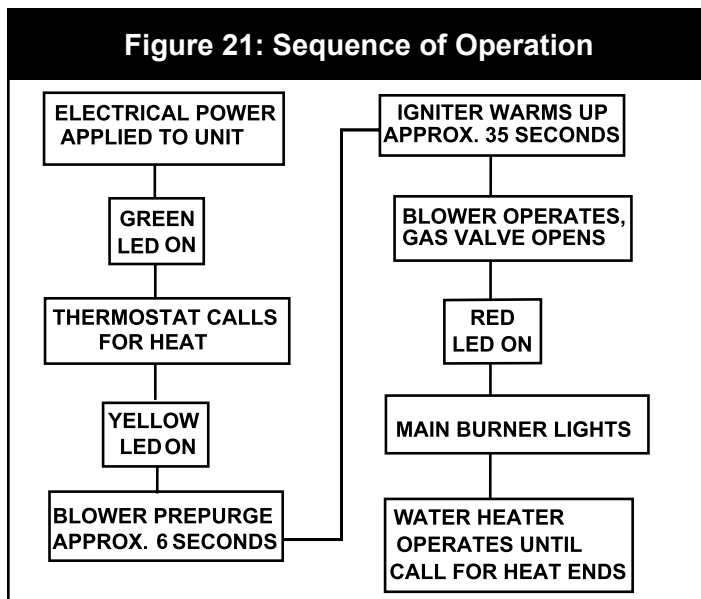
## L.P. (Propane) Models

Propane gas is heavier than air and in the occurrence of a leak in the system, the gas will settle on the floor level. Basements, crawl spaces, skirted areas under mobile homes (even when ventilated), closets and areas below ground level will serve as pockets for the accumulation of gas. Before lighting a propane gas water heater, smell all around the appliance at floor level. If you smell gas, follow the instructions as given in the warning on the front page.

When your propane tank runs out of fuel, turn off the gas at all gas appliances including pilot lights. After the tank is refilled, all appliances must be re-lit according to their manufacturer's instructions.

## Water Heater Operation

This water heater does not have a pilot light. It is equipped with an electronic ignition that automatically lights the burner. There are three lights to indicate the various stages of operation; **Green** = Electrical power is on, **Yellow** = Thermostat is calling for heat, which signals the beginning of the ignition sequence (see figure 21), and **Red** = Ignition control is signaling the gas valve to open.



When the thermostat calls for heat, the blower will run for 6 seconds to purge the system of any accumulated gas or air. The hot surface igniter will heat up for 35 seconds. The blower will turn on and the gas valve open, forcing the air and gas mixture across the hot surface igniter, causing the burner to light. The hot surface igniter will turn off and act as an electronic flame sensor to determine if burner ignition has been accomplished. If it detects any loss of flame, it will shut off the gas supply to the burner.

The ignition control will try to light the burner three times. If the ignition control does not detect a flame after three tries, it will temporarily lock out, but then auto restart and go through three additional tries for ignition after 60 minutes. It will repeat until ignition occurs or the system locks out requiring service. Refer to Troubleshooting Guide on Page 27.

## Thermostat Sensor

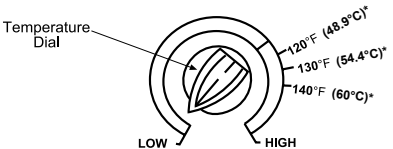
The sensor is a 10K ohm [at 77°F (25°C)] thermistor. Read resistance through the black wires that run to the sensor. Remove wires from circuit board before checking. An open or short circuit indicates sensor failure. Check reading against the values listed in Table 3. The resistance should correspond with the temperature in the tank:

**Table 3:**

Temperature		Resistance
60°F	16°C	15,300 ohms
80°F	27°C	9,300 ohms
100°F	38°C	5,800 ohms
120°F	49°C	3,800 ohms
140°F	60°C	2,500 ohms
160°F	71°C	1,700 ohms
185°F	85°C	1,100 ohms

## OPERATING INSTRUCTIONS

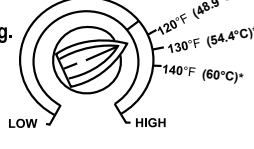
- Turn temperature dial counterclockwise ↶ to the lowest setting.
- Turn off electrical power to the appliance.



Temperature Dial

120°F (48.9°C)  
130°F (54.4°C)  
140°F (60°C)\*

LOW HIGH



120°F (48.9°C)  
130°F (54.4°C)  
140°F (60°C)\*

LOW HIGH

- This appliance is equipped with an ignition device which automatically lights the burner. Do not try to light the burner by hand.
- To clear any gas that may have accumulated, wait ten (10) minutes. If you smell gas, STOP! Refer to the safety warning on the front cover of this manual. If you do not smell gas, go to the next step.

- Turn on the electricity to the water heater. The green power light will glow.
- Turn the temperature dial clockwise ↷ to the desired setting. The yellow ignitor light will glow when the thermostat calls for heat. After 35 seconds, the burner will fire and the red burner light will glow.
- If the appliance will not operate after three automatic tries, follow these instructions once more. If the appliance still refuses to light, follow the instructions "To Turn Off Appliance" and call your service technician or gas supplier.

*\* Temperatures shown are approximates and may vary.*

---

## TO TURN OFF GAS TO APPLIANCE

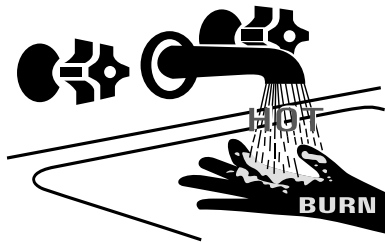
- Turn the temperature dial counterclockwise ↶ to the lowest setting.
- Turn off electric power to appliance if service is to be performed.
- Close the manual gas shut-off valve in the gas supply line near the water heater.

## Stacking

Stacking occurs when a series of short draws of hot water (3 gallons [11.3 liters] or less) are taken from the water heater tank. This causes increased cycling of the burner and can result in increased water temperatures at the hot water outlet. A mixing valve must be installed in the hot water supply line to reduce the risk of scald injury.

## Water Temperature Regulation

### ⚠ WARNING



**Water temperature over 125°F (51.6°C) can cause severe burns instantly or death from scalds.**

**Children, disabled and elderly are at highest risk of being scalded.**

**See instruction manual before setting temperature at water heater.**

**Feel water before bathing or showering.**

**Temperature limiting valves are available.**

The thermostat is adjusted to its lowest temperature setting when it is shipped from the factory. Water temperature can be regulated by moving the temperature dial to the preferred setting. The preferred starting point is 130°F (54.4°C); however, in some instances, setting the water heater higher than 130°F (54.4°C) can reduce the

occurrence of igniter failure due to excessive condensate.

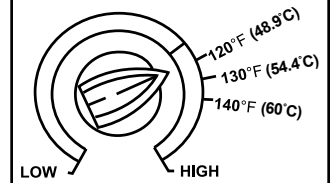
**Important:** A mixing valve (provided) must be installed in the hot water outlet to reduce the risk of scald injury when setting the thermostat in excess of 120°F (48.9°C).

Many home heating systems used with this water heater are designed for temperatures higher than 130°F (54.4°C). Refer to the manufacturer's instruction manuals supplied with this type of equipment for recommended temperature settings.

**Important:** Adjusting the thermostat past the 120°F (48.9°C) setting on the

temperature dial (see figure 22) will increase the risk of scald injury. Hot water can produce first degree burns within:

**Figure 22:  
Temperature Dial**



Water Temperature °F (°C)	Time for 1st Degree Burn (Less Severe Burns)	Time for Permanent Burns 2nd & 3rd Degree (Most Severe Burns)
110 (43.3)	(normal shower temp.)	
116 (46.7)	(pain threshold)	
116 (46.7)	35 minutes	45 minutes
122 (50)	1 minute	5 minutes
131 (55)	5 seconds	25 seconds
140 (60)	2 seconds	5 seconds
149 (65)	1 second	2 seconds
154 (67.8)	instantaneous	1 second

(U.S. Government Memorandum, C.P.S.C., Peter L. Armstrong, Sept. 15, 1978)

## Emergency Shut Down

**Important:** If overheating occurs or the gas supply fails to shut off, close the manual gas supply valve. Turn off the electrical supply to the unit and close the cold water supply valve. Do not operate the water heater again until it has been thoroughly checked by an authorized service technician.



## OPERATIONAL CONDITIONS

### Water Heater Sounds

During the normal operation of the water heater, sounds or noises may be heard. These noises are common and may result from the following:

1. Normal expansion and contraction of metal parts during periods of heat-up and cool-down.
2. Sediment buildup in the tank bottom will create varying amounts of noise and may cause premature tank failure. Drain and flush the tank as directed under "Draining and Flushing".

### Safety Shut-Off (Pressure Switch)

This water heater is equipped with a pressure switch that protects the unit by shutting it down in the event that:

- A blockage occurs in the combustion air inlet, the flue gas exhaust outlet, or both the inlet and outlet.
- The condensate line freezes and the condensate "backs up" and fills the exhaust outlet.
- The blower fails to operate, or operates improperly.
- The unit begins to operate at an abnormally low input level.

### Energy Cut-Off (ECO)

A high temperature limit switch, or ECO, is used to shut down the water heater if the water temperature exceeds 203°F (95°C). The ECO will automatically reset when the temperature cools sufficiently. If the ECO shuts down the heater repetitively, contact a qualified professional for service.

## MAINTENANCE

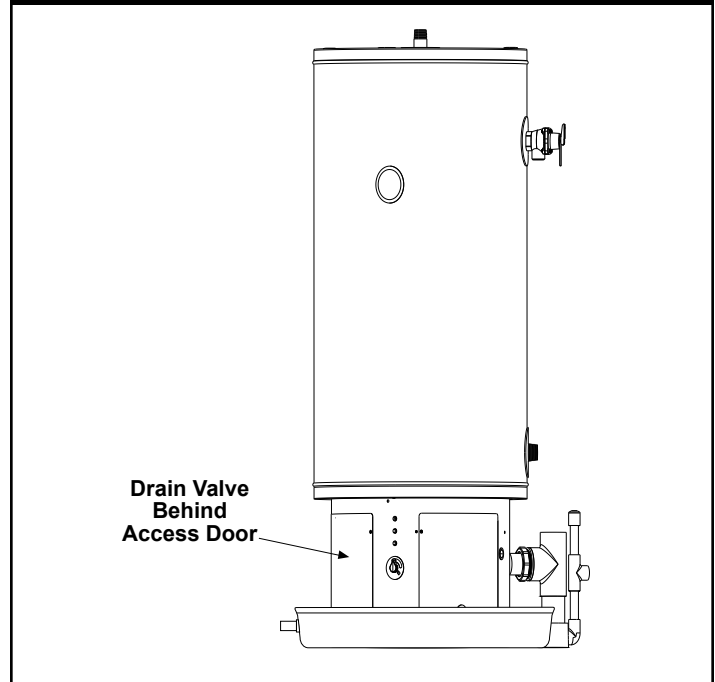
### Draining and Flushing

It is recommended that the tank be drained and flushed every 6 months to remove sediment which may buildup during operation. The water heater should be drained if being shut down during freezing temperatures.

To drain the tank, perform the following steps:

1. Turn off the gas supply at the Manual Gas Shut-off Valve. Turn off the electrical supply to the water heater.
2. Open a nearby hot water faucet and run until the water is no longer hot.
3. Close the cold water inlet valve.
4. Open the left-hand access panel at the bottom of the heater (see figure 23). Connect a hose to the drain valve and terminate it to an adequate drain or external to the building.
5. Open the water heater drain valve and allow all of the water to drain from the tank.
6. Flush tank to remove sediment.
7. Close the drain valve, replace access door, **refill the tank**, and restart the heater as directed under "Operating Your Water Heater".

Figure 23: Drain Valve Access

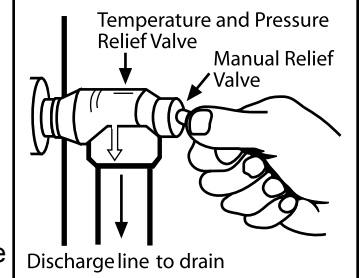


**IMPORTANT:** Condensation may occur when refilling the tank and should not be confused with a tank leak.

### Temperature and Pressure Relief Valve

Manually operate the temperature and pressure relief valve at least once a year to make sure it is working properly. To prevent water damage, the valve must be properly connected to a discharge line which terminates at an adequate drain. Standing clear of the outlet (discharged water may be hot), slowly lift and release the lever handle on the temperature and pressure relief valve to allow the valve to operate freely and return to its closed position (see figure 24). If the valve fails to completely reset and continues to release water, immediately shut off the manual gas valve and the cold water inlet valve, and call a qualified service technician.

Figure 24



# MAINTENANCE OF YOUR WATER HEATER

## 3 Month Inspection

At least every 3 months, a visual inspection should be made of the combustion air inlet as well as the exhaust and water piping. Check the water heater for the following:

- Obstructions, damage, or deterioration in the venting system. Make sure the exhaust and combustion air supplies are not obstructed.
- Leaking or damaged water and gas piping.
- Presence of flammable or corrosive materials in the installation area.
- Presence of combustible materials near the water heater.

**Important:** Verify proper operation after servicing this water heater.

## Gas Valve

The gas valve on this water heater has been permanently set at the factory for proper operation. No field adjustments are needed and none should be performed.

## Removing the Gas Valve

Removal and replacement of the gas regulator valve involves the disconnection of gas piping and electrical leads. This procedure must be performed by a qualified service technician.

**Important:** When removing the gas valve, do not use a pipe wrench or vise to grip the body. Do not apply any force to the gas valve or the cast flange fitting on the inlet side of the gas valve (see figure 25.) Such force may break or crack these components.

1. Turn temperature dial counterclockwise to the lowest setting and turn off electrical power to appliance.
2. Shut off the gas at the manual shut-off valve on the gas supply line. See figure 19 for reference. Remove the access door.
3. Disconnect the gas piping connection just outside the base of the water heater. Note: Use a second pipe wrench on the gas piping inside the skirt to avoid cracking the gas valve or the flange fitting.
4. Remove the pressure tap from the gas valve (see figure 25). The hose should not be disconnected.
5. Remove the Phillips head screw holding the electrical plug and remove electrical plug from the gas valve.
6. Remove the three T-25 Torx head brass screws that attach the gas valve to the venturi manifold, using the T-25 Torx wrench supplied with the gas valve kit (model VK8115V, part number 6903775.)
7. Remove the gas valve from the unit keeping the rubber gasket with the gas valve.
8. Remove the flange from the gas inlet side of the valve by removing the four (4) attachment screws.

## Replacing the Gas Valve

**Important:** The rubber gasket that seals the gas valve to the venturi manifold must be used (previous gaskets may be reused, if in good condition). Make sure the gasket is properly inserted into the recess on the gas valve prior to installation (see figure 25 for exact placement of the rubber gasket).

1. Remove the O-ring from the flange (removed from the old gas valve) and replace it with the one provided in the gas valve kit (model VK8115V, part number 6903775.)
2. Reattach the elbow flange to the gas valve. Tighten all four screws securely.
3. Place the three T-25 Torx screws through the proper holes in the venturi manifold flange. See figure 25.
4. Properly install a new rubber gasket (provided) as shown in figure 25.
5. Position the gas valve and start all three screws (projecting downward from the venturi manifold) into the gas valve. A T-25 Torx wrench has been provided in the gas valve replacement kit (model VK8115V, part number 6903775.)

**Note:** All three T-25 Torx screws must be properly tightened to secure the seal between the gas valve and the venturi manifold.

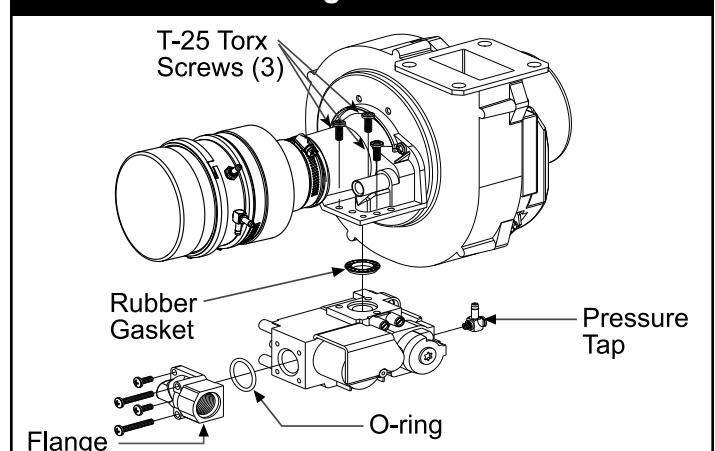
6. Reconnect the pressure tap to the port on the new gas valve (see figure 25).
7. Reconnect the external gas supply line to the gas piping on the gas valve. Be sure to use approved Teflon tape or pipe joint compound suitable for gas piping.
8. Reconnect the electrical plug to the gas valve and secure it with the screw provided.
9. Turn gas supply on and check for leaks. Use a chloride-free soap and water solution (bubbles forming indicate a leak) or other approved method. All leaks must be fixed immediately.

**Note:** Use a second pipe wrench on the gas piping inside the skirt to avoid cracking the gas valve or the cast fitting.

10. Be sure tank is completely filled with water before restoring power to the water heater. Follow operating instructions on Page 24.
11. Ensure proper operation of the water heater, then reinstall the access door.

If additional information is required, contact the Product Service and Support Group through our website: [www.americanwaterheater.com](http://www.americanwaterheater.com).

Figure 25

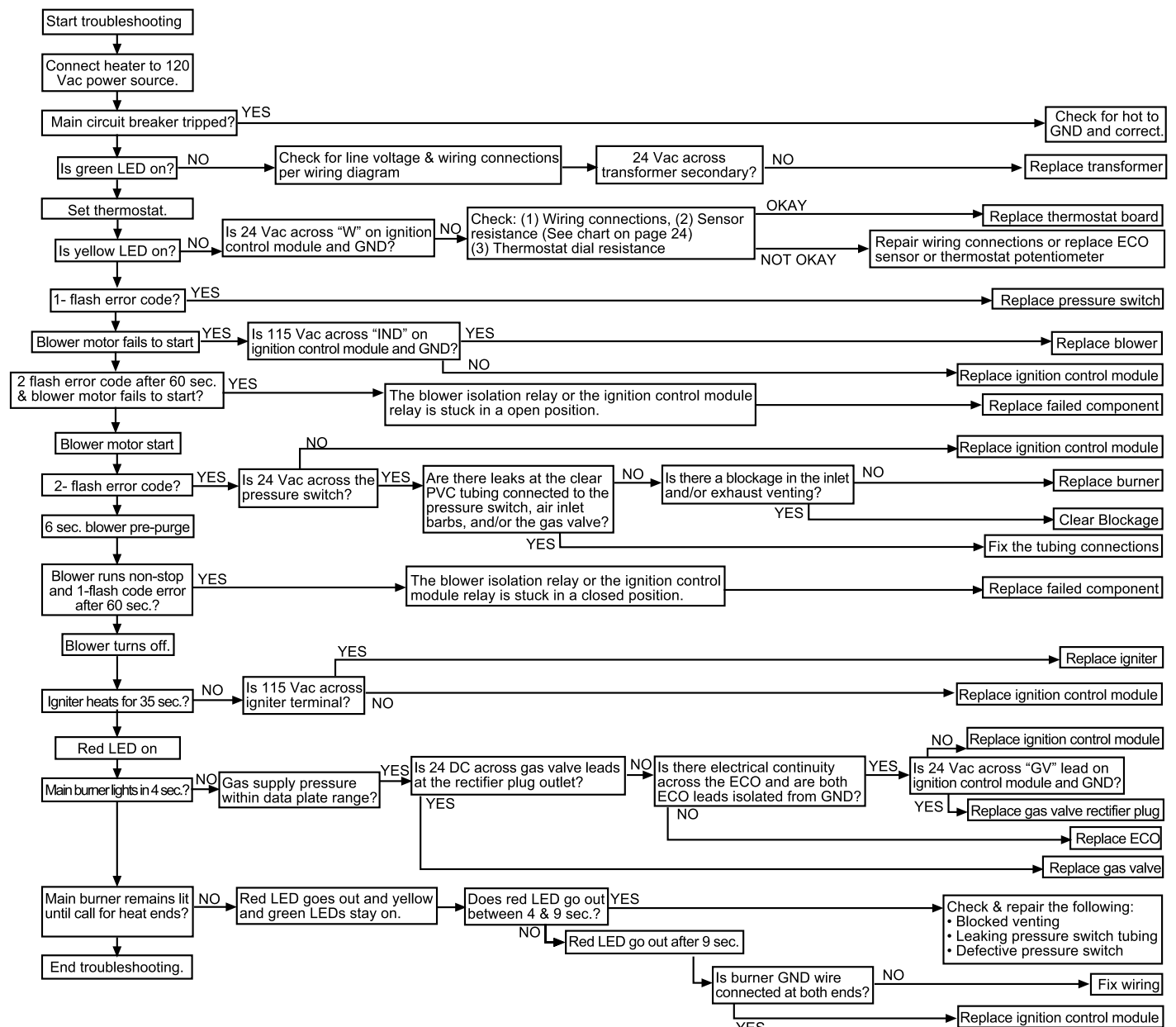


# TROUBLESHOOTING

**Table 5:**  
**Ignition Control Module (ICM) LED Error Codes:** (Flashes visible through viewport in access door)

FLASHES	INDICATED PROBLEM	CONTROL REACTION
1	Pressure Switch Closed	SC*
2	Pressure Switch Open	SL
3	Failed Ignition	SL3
4	Gas Valve Hardware Fault	SL
5	Flame Sense Hardware Fault	SC
6	False Flame	SL**
8	Ignition Control Hardware Fault	SL
9	Ignition Control Software Fault	SL
Rapid	L1 Polarity Detection	SC

SL (Soft Lockout): Control Automatically resets after 60 minutes.  
 SL3 (Soft Lockout/Hard Lockout): Control automatically resets after 60 minutes, with a maximum of 3 resets, followed by hard lockout requiring service.  
 SC (Self Clearing): Control will function normally as soon as it no longer detects the previously indicated fault.  
 \* when pressure switch or blower relay opens  
 \*\* when flame is no longer sensed.  
 † Blower Isolation Relay is used on models 150,000 BTU/Hr and above.  
 Note: If unit goes into a soft or hard lock-out the ignition control module can be reset by cycling power to the water heater.





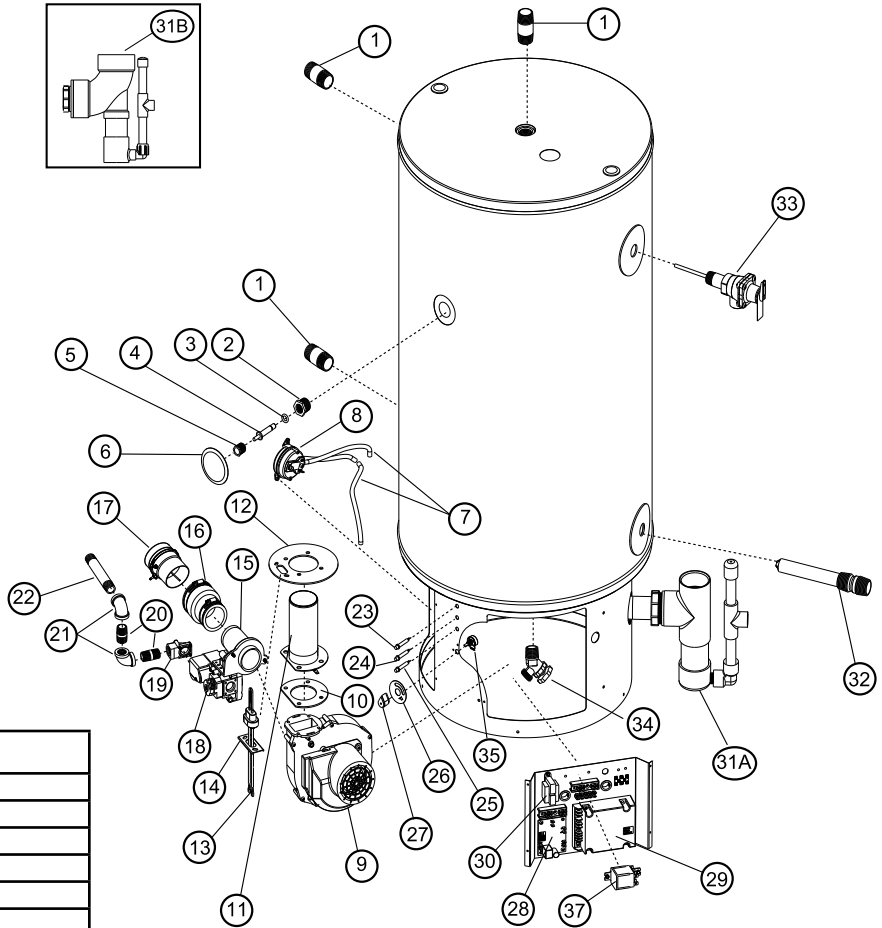
# REPAIR PARTS LIST/DIAGRAM

When ordering repair parts always give the following information:

1. Model, serial, and product numbers
2. Type of gas
3. Item number
4. Parts description

## Repair Parts List

ITEM NO.	PARTS DESCRIPTION
1	1" NPT x 2.5" BRASS NIPPLE
2	THERMOSTAT SENSOR BUSHING
3	O-RING
4	THERMOSTAT SENSOR/ECO
5	INVERTED FLARE NUT
6	PLUG
7	VINYL TUBING
8	PRESSURE SWITCH
9	COMBUSTION BLOWER
10	4 INCH (10.16 cm) DIAMETER BLOWER GASKET
11	BURNER (NATURAL AND L.P. SAME)
12	6 INCH (15.24 cm) DIAMETER BURNER GASKET
13	HOT SURFACE IGNITER
14	IGNITER BRACKET
15	VENTURI MANIFOLD
16	REDUCING COUPLING
17	INLET AIR / FILTER ASSEMBLY
18	GAS VALVE
19	1/2" NPT 90 DEGREE INLET FLANGE
20	1/2" NPT X 2" NIPPLES
21	1/2" NPT ELBOWS
22	1/2" NPT X 4.5" NIPPLE
23	RED LED
24	YELLOW LED
25	GREEN LED
26	THERMOSTAT BEZEL
27	TEMPERATURE SELECTOR KNOB
28	THERMOSTAT BOARD
29	IGNITION CONTROL
30	TRANSFORMER
31A	2" (DN 50mm) CONDENSATE TRAP ASSEMBLY
31B	3" (DN 80mm) CONDENSATE TRAP ASSEMBLY
32	COLD WATER TUBE ASSEMBLY
33	TEMPERATURE AND PRESSURE RELIEF VALVE
34	DRAIN VALVE
35	POTENTIOMETER
36	VENTURI GASKET (not pictured)
37	BLOWER ISOLATION RELAY



## TOOLS REQUIRED FOR SERVICING

TOOL	FUNCTION
VOLT OHMMETER	MEASURE VOLTAGE/RESISTANCE
CLAMP-ON AMMETER	MEASURE CURRENT
STOPWATCH	CLOCK GAS CONSUMPTION
CALCULATOR	CALCULATE INPUT RATE
U-TUBE MANOMETER	READ INLET GAS PRESSURE
3/16-inch (≈ 4.76 mm) ID PLASTIC TUBING (2 FT [61 cm])	CONNECT MANOMETER
#1 & #2 PHILLIPS SCREWDRIVERS	REMOVE DOORS AND CONTROLS
12" (30.48 cm) PIPE WRENCH (2 REQUIRED)	REMOVE GAS LINE
SAE 1/2" COMBINATION WRENCH	REMOVE BLOWER AND BURNER
SAE 1/2" SOCKET AND RATCHET	REMOVE BLOWER AND BURNER
SAE 3/8" COMBO WRENCH/NUT DRIVER	REMOVE IGNITER
T-25 TORX WRENCH	REMOVE THE GAS VALVE

(ALSO HELPFUL - SAE 9/32" and 5/16" COMBINATION WRENCHES)

# POLARIS MODELS & DIMENSIONS

Figure 26

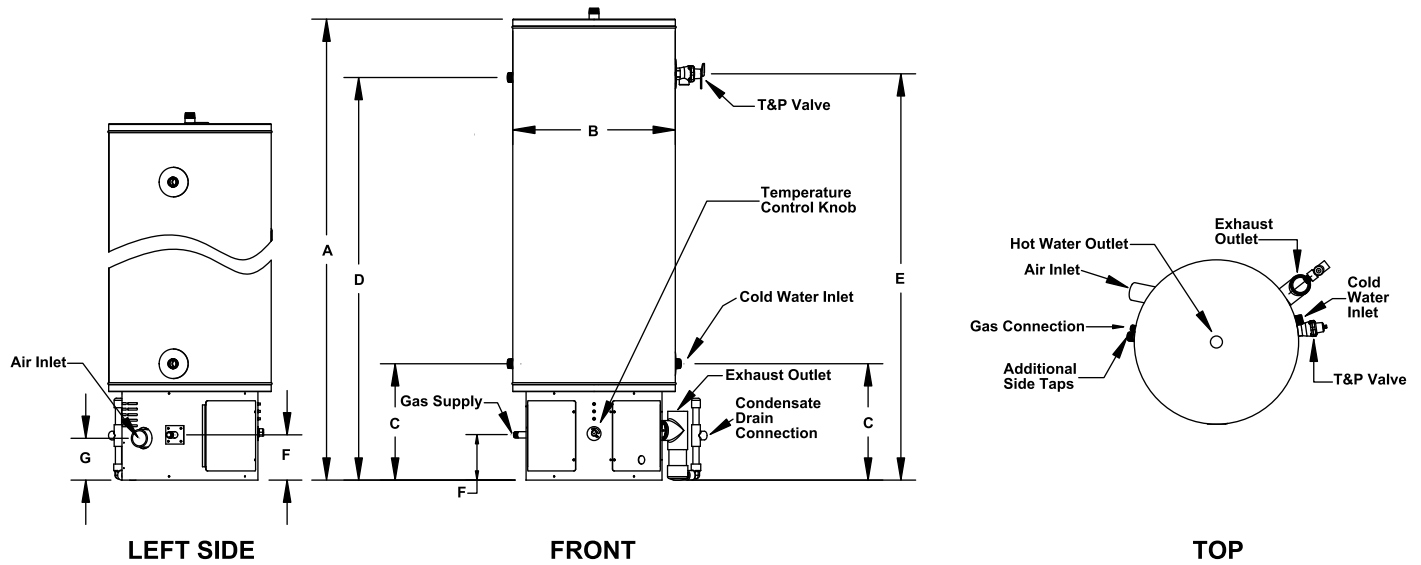


Table 6:

MODEL NUMBER	GAL. CAP.	INPUT (MBTU PER HR.)	VENT DIA.	EXTERIOR		WATER CONNECTIONS		T&P HGT	GAS SUPPLY	AIR INLET/EX-HAUST	APPROX SHIP. WEIGHT
				A	B	C	D				
PGC* 34-100-2NV OR 2PV	34	100	2 OR 3	48-1/2	22	15-3/4	40-1/2	41	6-3/8	5-1/2 / 6-5/8	150
PGC* 34-130-2NV OR 2PV	34	130	2 OR 3	48-1/2	22	15-3/4	40-1/2	41	6-3/8	5-1/2 / 6-5/8	150
PGC* 34-150-2NV OR 2PV	34	150	2 OR 3	48-1/2	22	15-3/4	40-1/2	41	6-3/8	5-1/2 / 6-5/8	150
PGC* 50-130-2NV OR 2PV	50	130	2 OR 3	62-3/8	22	15-3/4	54-1/2	55	6-3/8	5-1/2 / 6-5/8	176
PGC* 50-150-2NV OR 2PV	50	150	2 or 3	63-3/4	22	15-3/4	55-3/4	56-1/4	6-3/8	5-1/2 / 6-5/8	180
PGC* 50-175-3NV OR 3PV	50	175	3	63-3/4	22	15-3/4	55-3/4	56-1/4	6-3/8	5-1/2 / 6-5/8	180
PGC* 50-199-3NV OR 3PV	50	199	3	63-3/4	22	15-3/4	55-3/4	56-1/4	6-3/8	5-1/2 / 6-5/8	180

\* Indicates warranty period

---

## NOTES

---

Polaris®  
Commercial Gas Water Heater



P.O. Box 1597, Johnson City, TN 37605

To obtain technical, warranty or service assistance during or after the installation of this water heater, visit our website at:

<http://www.americanwaterheater.com>

or call toll free:  
1-800-456-9805