



Con-Stab ID Seal® Fittings have been sold in the gas, plumbing, and propane markets since 1990. **Con-Stab®** fittings are IAPMO, CSA, & ICC approved.



for: **Pool Heaters**



for: **Gas Grills**



for: **Patio Hearths & Lighting**



for: **Emergency Generators**

CON-STAB® ANODELESS METER RISERS

- Fusion-bonded epoxy coating
- Anodeless and corrosion resistant
- Patented "ID-Seal" fitting (inside chamfer)

Always Match **Pipe Size & SDR**

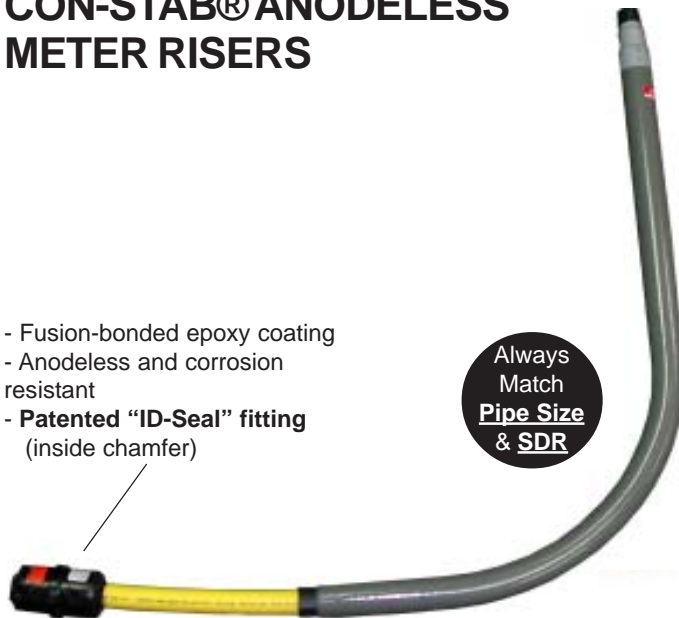

W-R	Size	Wall (CTS) or SDR
2886036	1/2" CTS	.090
2886004	3/4" IPS	SDR-11
2886008	1" IPS	SDR-11
2886040	1" CTS	.099/.101
2886012	1 1/4" IPS	SDR-10
2886013	1 1/4" IPS	SDR-11
2886016	1 1/2" IPS	SDR-11
2886020	2" IPS	SDR-11

IMPORTANT
CHAMFER THE ID OF PIPE



You must use a **Continental Chamfer Tool** on a **Continental Fitting!**



POLY-END ANODELESS METER RISERS

- Fusion-bonded epoxy coating
- Anodeless and corrosion resistant
- Plain PE end can be used with compression & "stab" fittings
- 3" must be used with Dresser Style 711 couplings. See page 6.

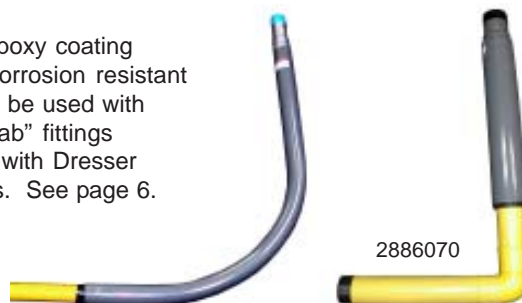

2886070

W-R	Size	Wall (CTS) or SDR
2886002	3/4" IPS	SDR-11
2886006	1" IPS	SDR-11
2886030	1" CTS	.099/.101
2886010	1 1/4" IPS	SDR-10
2886011	1 1/4" IPS	SDR-11
2886014	1 1/2" IPS	SDR-11
2886018	2" IPS	SDR-11
2886070	3" IPS	SDR-11.5



Con-Stab ID Seal® Fittings have been sold in the gas, plumbing, and propane markets since 1990. **Con-Stab®** fittings are IAPMO, CSA, & ICC approved.

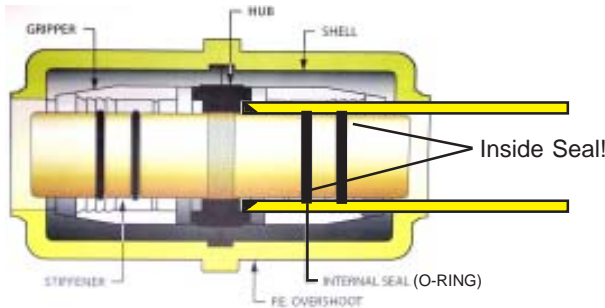

Con-Stab®'s patented "ID-Seal" is formed on the **INSIDE** of the pipe--where the surface is the smoothest. Therefore you must chamfer the **INSIDE** of your pipe with a **Continental® Chamfer tool**.

From NFPA 54 Section 3.3.5
 "An **anodeless riser** is an assembly of steel-cased plastic pipe used to make the transition between plastic piping underground and metal piping aboveground."

Plastic Pipe runs inside the riser.

Corrosion-resistant fusion-bonded epoxy coating



CON-STAB® COUPLINGS



Always Match **Pipe Size & SDR**



W-R	Size	Wall (CTS) or SDR
2881000	1/2"	CTS .090
2881002	3/4"	IPS SDR-11
2881004	1"	IPS SDR-11
2881020	1"	CTS .099/.101
2881006	1 1/4"	IPS SDR-10
2881007	1 1/4"	IPS SDR-11
2881008	1 1/2"	IPS SDR-11
2881010	2"	IPS SDR-11

CON-STAB® ELBOWS



Always Match **Pipe Size & SDR**



W-R	Size	Wall (CTS) or SDR
2882000	1/2"	CTS .090
2882002	3/4"	IPS SDR-11
2882004	1"	IPS SDR-11
2882020	1"	CTS .099/.101
2882006	1 1/4"	IPS SDR-10
2882007	1 1/4"	IPS SDR-11
2882008	1 1/2"	IPS SDR-11
2882010	2"	IPS SDR-11

CON-STAB® TEES



Always Match **Pipe Size & SDR**



W-R	Size	Wall (CTS) or SDR
2883000	1/2"	CTS .090
2883002	3/4"	IPS SDR-11
2883004	1"	IPS SDR-11
2883020	1"	CTS .099/.101
2883006	1 1/4"	IPS SDR-10
2883007	1 1/4"	IPS SDR-11
2883008	1 1/2"	IPS SDR-11
2883010	2"	IPS SDR-11



Con-Stab ID Seal® Fittings have been sold in the gas, plumbing, and propane markets since 1990. **Con-Stab®** fittings are IAPMO, CSA, & ICC approved.

CON-STAB® MALE ADAPTERS



Always Match Pipe Size & SDR



W-R	Size	Wall (CTS) or SDR
2885000	1/2"	CTS .090
2885002	3/4"	IPS SDR-11
2885004	1"	IPS SDR-11
2885020	1"	CTS .099/.101
2885006	1 1/4"	IPS SDR-10
2885007	1 1/4"	IPS SDR-11
2885008	1 1/2"	IPS SDR-11
2885010	2"	IPS SDR-11

- Standard sizes with 4" long steel MIP stub.

POLY PLAIN-END MALE ADAPTERS



Always Match Pipe Size & SDR



W-R	Size	Wall (CTS) or SDR
2885050	3/4"	IPS SDR-11
2885052	1"	IPS SDR-11
2885070	1"	CTS .099/.101
2885054	1 1/4"	IPS SDR-10
2885055	1 1/4"	IPS SDR-11
2885056	1 1/2"	IPS SDR-11
2885058	2"	IPS SDR-11

- Standard sizes with 4" long steel MIP stub.
 - Plain End can be used with stab couplings, compression couplings, and fusion fittings.



CON-STAB® CHAMFER TOOL

Always Match Pipe Size & SDR

LOOK FOR THE "C"

You must use a **Continental** Chamfer Tool on a **Continental** Fitting!

W-R	Size	Wall (CTS) or SDR
2888020	1/2"	CTS .090
2888014	3/4"	IPS SDR-11
2888016	1"	IPS SDR-11
2888022	1"	CTS .099/.101
2888006	1 1/4"	IPS SDR-10
2888007	1 1/4"	IPS SDR-11
2888008	1 1/2"	IPS SDR-11
2888010	2"	IPS SDR-11

- **Follow the Arrow!** Turn the tool in the direction of the arrow printed on the tool for a clean, even chamfer (bevel) on the inside of the pipe.



Con-Stab ID Seal® Fittings have been sold in the gas, plumbing, and propane markets since 1990. **Con-Stab®** fittings are IAPMO, CSA, & ICC approved.



CON-STAB® x COPPER TRANSITION FITTING

Always Match Pipe Size & SDR



W-R	Con-Stab®	Copper Tube
2884002	3/4" SDR 11	1/2" Flare

- Con-Stab® x Flare connection for copper tubing



CON-STAB® REDUCING COUPLINGS

IPS X IPS

Always Match Pipe Size & SDR



W-R	IPS X IPS REDUCERS
2891030	1" SDR11 x 3/4" SDR11

2891049	1 1/4" SDR10 x 3/4" SDR11
2891021	1 1/4" SDR10 x 1" SDR11

2891050	1 1/4" SDR11 x 3/4" SDR11
2891022	1 1/4" SDR11 x 1" SDR11

2891010	1 1/2" SDR11 x 3/4" SDR11
2891012	1 1/2" SDR11 x 1" SDR11
2891013	1 1/2" SDR11 x 1 1/4" SDR10
2891014	1 1/2" SDR11 x 1 1/4" SDR11

2891002	2" SDR11 x 3/4" SDR11
2891004	2" SDR11 x 1" SDR11
2891005	2" SDR11 x 1 1/4" SDR10
2891006	2" SDR11 x 1 1/4" SDR11
2891008	2" SDR11 x 1 1/2" SDR11

CTS X IPS

Always Match Pipe Size & SDR



W-R	CTS X IPS REDUCERS
2890040	1/2" CTS x 3/4" SDR11
2890042	1/2" CTS x 1" SDR11

2890002	1" CTS x 3/4" SDR11
2890004	1" CTS x 1" SDR11



SDR-11

SDR-10

CON-STAB® 1 1/4" SDR-10 x SDR-11 ADAPTER

"THE MIRACLE FITTING"

W-R	Con-Stab® A	Con-Stab® B
2890008	1 1/4" IPS x SDR-10	1 1/4" IPS SDR-11



Con-Stab ID Seal® Fittings have been sold in the gas, plumbing, and propane markets since 1990. **Con-Stab®** fittings are IAPMO, CSA, & ICC approved.

CON-STAB® REDUCING TEES



Always Match Pipe Size & SDR



W-R	RUN	BRANCH
2883070	1" SDR11 x 3/4"	SDR11
2883061	1 1/4" SDR10 x 3/4"	SDR11
2883063	1 1/4" SDR10 x 1"	SDR11
2883062	1 1/4" SDR11 x 3/4"	SDR11
2883064	1 1/4" SDR11 x 1"	SDR11
2883080	1 1/2" SDR11 x 3/4"	SDR11
2883082	1 1/2" SDR11 x 1"	SDR11
2883083	1 1/2" SDR11 x 1 1/4"	SDR10
2883084	1 1/2" SDR11 x 1 1/4"	SDR11
2883050	2" SDR11 x 3/4"	SDR11
2883052	2" SDR11 x 1"	SDR11
2883053	2" SDR11 x 1 1/4"	SDR10
2883054	2" SDR11 x 1 1/4"	SDR11
2883056	2" SDR11 x 1 1/2"	SDR11

CON-STAB® SADDLE PUNCH TEES



Always Match Pipe Size & SDR



W-R	MAIN	OUTLET
2893090	1 1/4"	3/4" SDR-11
2893092	1 1/4"	1" SDR-11
2896002	1 1/2"	3/4" SDR-11
2896006	1 1/2"	1" SDR-11
2894002	2"	3/4" SDR-11
2894004	2"	1" SDR-11
2894006	2"	1 1/4" SDR-11
2894502	3"	3/4" SDR-11
2894504	3"	1" SDR-11
2894506	3"	1 1/4" SDR-11
2894508	3"	2" SDR-11



Con-Stab ID Seal® Fittings have been sold in the gas, plumbing, and propane markets since 1990. **Con-Stab®** fittings are IAPMO, CSA, & ICC approved.



CON-STAB® END CAPS

Always Match **Pipe Size & SDR**



W-R	Size	Wall (CTS) or SDR
2892000	1/2" CTS	.090
2892002	3/4" IPS	SDR-11
2892004	1" IPS	SDR-11
2892020	1" CTS	.099/.101
2892006	1 1/4" IPS	SDR-10
2892007	1 1/4" IPS	SDR-11
2892008	1 1/2" IPS	SDR-11
2892010	2" IPS	SDR-11

CONFLEX® FLEX RISERS FOR PROPANE



Continental “**Con-Flex®**” risers are **flexible** casings that protect **yellow polyethylene pipe** aboveground. **Con-flex®** risers consist of corrugated stainless steel flex hose, with a durable UV & weather-resistant outer sleeve. Conforms to NFPA 54 & 58 for LPG systems.

W-R	Description	Length
2887002	1/2" COP x 1/2" MIP	36"
2887004	1/2" COP x 1/2" MIP	84"
2887020	3/4" IPS x 3/4" MIP	36"
2887030	1" IPS x 1" MIP	36"



Instructions:

1. Disassemble the **adapter coupling** (B).
2. Feed the polyethylene pipe through the sleeve from the **moisture seal** (A) to the **adapter coupling** (B)
3. Assemble the **adapter coupling** by sliding the gasket over the tubing, and then pushing the tubing onto the insert. Tighten the compression nut until it bottoms out.



POLYETHYLENE GAS BALL VALVES

Always Match **Pipe Size & SDR**



W-R	Size	Wall (CTS) or SDR
2893102	3/4"	IPS SDR-11
2893104	1"	IPS SDR-11
2893106	1 1/4"	IPS SDR-11
2893108	1 1/2"	IPS SDR-11
2893110	2"	IPS SDR-11

Step 1: Match Pipe & SDR

BE SURE TO MATCH PIPE SIZE & SDR*

Pipe, Fittings, and Chamfer Tool must be the same!

*“SDR” stands for “Standard Dimension Ratio”. It is a designation of a pipe’s pressure rating. SDR is the ratio of Pipe Diameter to Wall Thickness.

Step 2: Chamfer Inside of Pipe

BEFORE

SQUARE-CUT

CHAMFER INSIDE

AFTER

CHAMFERED

Follow the arrows printed on the label. Only 3-5 turns necessary for a good chamfer!

The “coupon” is the piece of yellow poly that is shaved off during the act of chamfering.

Test your chamfer by pushing the pipe over the test gauge. If the pipe is chamfered properly, it should fit over the test gauge with minimum effort.

Test Gauge

Step 3: Mark Stab Depth

MARK THE STAB DEPTH!

1. Line up the end of the yellow pipe with the hub of the fitting.
2. Mark a line on the pipe to approximate the end of the fitting.
3. **Goal:** The reason to mark the stab depth is to ensure that the pipe is sealed by **both** o-rings!

“Hub”

(O-RING)

Step 4: Stab & Check

STAB PIPE INTO FITTING

Stab the pipe completely into the fitting, so that the “stab marker” is within 1/8” from the entrance of the fitting.

Once the pipe has been stabbed, it **cannot** be removed.

LOOK FOR THE “C”

You must use a **Continental Chamfer Tool** on a **Continental Fitting!**



**YELLOW PLASTIC
GAS PIPE**

**YELLOW "MEDIUM DENSITY"
(PE2406) PE GAS PIPE**



**NEW! 50 FOOT
CONVENIENCE COILS**

Conforms to ASTM D-2513



Gas

**Always
Match
Pipe Size
& SDR**

For several years, the gas utility and distribution market has used plastic gas pipe for its **ease-of-use, corrosion resistance, and cost effectiveness**. *NFPA 54* provides for the use of plastic piping within it's code for **outdoor, underground use only** at a **minimum burial depth of 18"**, using **yellow 14g tracer wire** for location purposes.



Call us today for:

- Free promotional materials
- One-on-One sales training
- Sizing/Technical assistance

W-R	Size	Wall (CTS) or SDR	Length
2880004	1/2" CTS	.090	500'
2880011	3/4" IPS	SDR-11	50'
2880012	3/4" IPS	SDR-11	150'
2880016	3/4" IPS	SDR-11	500'
2880020	1" CTS	.099/.101	150'
2880021	1" CTS	.099/.101	500'
2880025	1" IPS	SDR-11	50'
2880022	1" IPS	SDR-11	150'
2880026	1" IPS	SDR-11	500'
2880029	1 1/4" IPS	SDR-10	50'
2880030	1 1/4" IPS	SDR-10	150'
2880031	1 1/4" IPS	SDR-11	50'
2880032	1 1/4" IPS	SDR-11	150'
2880036	1 1/4" IPS	SDR-11	500' (*)
2880041	1 1/2" IPS	SDR-11	50'
2880042	1 1/2" IPS	SDR-11	150'
2880046	1 1/2" IPS	SDR-11	500' (*)
2880051	2" IPS	SDR-11	50'
2880052	2" IPS	SDR-11	100'
2880056	2" IPS	SDR-11	500' (*)
2880062	3" IPS	SDR-11.5	100' (*)

(*) Call for availability

LOW PRESSURE < 2PSI

HIGH PRESSURE = 2PSI

Pressure Drop: .5 in w.c. Spec. Gravity: .60						
Length (feet)	1/2 IPS SDR-9.3	3/4 IPS SDR-11	1 IPS SDR-11	1 1/4 IPS SDR-10	1 1/2 IPS SDR-11	2 IPS SDR-11
10	201	403	726	1260	1900	3410
20	138	277	499	865	1310	2350
30	111	222	401	695	1050	1880
40	95	190	343	594	898	1610
50	84	169	304	527	796	1430
60	76	153	276	477	721	1300
70	70	140	254	439	663	1190
80	65	131	236	409	617	1110
90	61	123	221	383	579	1040
100	58	116	209	362	547	983
125	51	103	185	321	485	871
150	46	93	168	291	439	789
175	43	86	154	268	404	726
200	40	80	144	249	376	675
250	35	71	127	221	333	598
300	32	64	115	200	302	542
350	29	59	106	184	278	499
400	27	55	99	171	258	464
450	26	51	93	160	242	435
500	24	48	88	152	229	411

Pressure Drop: 1.0 in w.c. Spec. Gravity: .60						
Length (feet)	1/2 IPS SDR-9.3	3/4 IPS SDR-11	1 IPS SDR-11	1 1/4 IPS SDR-10	1 1/2 IPS SDR-11	2 IPS SDR-11
10	1860	3720	6710	11600	17600	31600
20	1280	2560	4610	7990	12100	21700
30	1030	2050	3710	6420	9690	17400
40	878	1760	3170	5490	8300	14900
50	778	1560	2810	4870	7350	13200
60	705	1410	2550	4410	6660	12000
70	649	1300	2340	4060	6130	11000
80	603	1210	2180	3780	5700	10200
90	566	1130	2050	3540	5350	9610
100	535	1070	1930	3350	5050	9080
125	474	949	1710	2970	4480	8050
150	429	860	1550	2690	4060	7290
175	395	791	1430	2470	3730	6710
200	368	736	1330	2300	3470	6240
250	326	652	1180	2040	3080	5530
300	295	591	1070	1850	2790	5010
350	272	544	981	1700	2570	4610
400	253	506	913	1580	2390	4290
450	237	475	856	1480	2240	4020
500	224	448	809	1400	2120	3800

NATURAL GAS

LOW PRESSURE: 11 IN. W.C.

HIGH PRESSURE = 2PSI

Pressure Drop: .5 in w.c. Spec. Gravity: 1.50						
Length (feet)	1/2 IPS SDR-9.3	3/4 IPS SDR-11	1 IPS SDR-11	1 1/4 IPS SDR-10	1 1/2 IPS SDR-11	2 IPS SDR-11
10	340	680	1230	2130	3210	5770
20	233	468	844	1460	2210	3970
30	187	375	677	1170	1770	3180
40	160	321	580	1000	1520	2730
50	142	285	514	890	1340	2420
60	129	258	466	807	1220	2190
70	119	237	428	742	1120	2010
80	110	221	398	690	1040	1870
90	103	207	374	648	978	1760
100	98	196	353	612	924	1660
125	87	173	313	542	819	1470
150	78	157	284	491	742	1330
175	72	145	261	452	683	1230
200	67	135	243	420	635	1140
250	60	119	215	373	563	1010
300	54	108	195	338	510	916
350	50	99	179	311	469	843
400	46	92	167	289	436	784
450	43	87	157	271	409	736
500	41	82	148	256	387	695

Pressure Drop: 1.0 in w.c. Spec. Gravity: 1.50						
Length (feet)	1/2 IPS SDR-9.3	3/4 IPS SDR-11	1 IPS SDR-11	1 1/4 IPS SDR-10	1 1/2 IPS SDR-11	2 IPS SDR-11
10	3130	6260	11300	19600	29500	53100
20	2150	4300	7760	13400	20300	36500
30	1730	3450	6230	10800	16300	29300
40	1480	2960	5330	9240	14000	25100
50	1310	2620	4730	8190	12400	22200
60	1190	2370	4280	7420	11200	20100
70	1090	2180	3940	6830	10300	18500
80	1010	2030	3670	6350	9590	17200
90	952	1910	3440	5960	9000	16200
100	899	1800	3250	5630	8500	15300
125	797	1600	2880	4990	7530	13500
150	722	1450	2610	4520	6830	12300
175	664	1330	2400	4160	6280	11300
200	618	1240	2230	3870	5840	10500
250	548	1100	1980	3430	5180	9300
300	496	994	1790	3110	4690	8430
350	457	914	1650	2860	4320	7760
400	425	851	1530	2660	4020	7220
450	399	798	1440	2500	3770	6770
500	377	754	1360	2360	3560	6390

PROPANE

* Values listed are in cubic feet/meter (cfm). To calculate BTU, multiply by 1000.

** Source: NFPA 54-2012 Table 6.2 (s)

* Values listed are in cubic feet/meter (cfm). To calculate BTU, multiply by 1000.

** Source: NFPA 54-2012 Table 6.2 (s)

*Reproduced with permission from NFPA 54, *National Fuel Gas Code*, Copyright 2012. This reprinted material is not the complete and official position of the NFPA on the referenced subject, which is represented only by the standard in its entirety. Please consult your NFPA 54/ICC Fuel Gas codebook and appliance's technical literature for more detailed sizing and installation instructions.

FIRST-STAGE TO SECOND STAGE

Pressure Drop: 1.0 in w.c.		Spec. Gravity: 1.50				
Length (feet)	1/2 IPS SDR-9.3	3/4 IPS SDR-11	1 IPS SDR-11	1 1/4 IPS SDR-10	1 1/2 IPS SDR-11	2 IPS SDR-11
30	2143	4292	7744	13416	20260	36402
40	1835	3673	6628	11482	17340	31155
50	1626	3256	5874	10176	15368	27612
60	1473	2950	5322	9220	13924	25019
70	1355	2714	4896	8483	12810	23017
80	1261	2525	4555	7891	11918	21413
90	1183	2369	4274	7404	11182	20091
100	1117	2238	4037	6994	10562	18978
125	990	1983	3578	6199	9361	16820
150	897	1797	3242	5616	8482	15240
175	826	1653	2983	5167	7803	14020
200	778	1539	2775	4807	7259	13043
250	681	1363	2459	4260	6434	11560
300	617	1235	2228	3860	5830	10474
350	567	1136	2050	3551	5363	9636
400	528	1057	1907	3304	4989	8965
450	495	992	1789	3100	4681	8411
500	468	937	1690	2928	4422	7945

PROPANE

* Capacities listed are based on a pressure of 10 psig first stage setting and 1 psi pressure drop.

* Values listed are in cubic feet/meter (cfm). To calculate BTU, multiply by 1000.

** Source: NFPA 58-2012 Table 15.1 (s)

*Reproduced with permission from NFPA 54, *National Fuel Gas Code*, Copyright 2012. This reprinted material is not the complete and official position of the NFPA on the referenced subject, which is represented only by the standard in its entirety. Please consult your NFPA 54/ICC Fuel Gas codebook and appliance's technical literature for more detailed sizing and installation instructions.



YELLOW TRACER WIRE

W-R#	Description
------	-------------

- 1842500** 500' Yellow Tracer Wire-14g
- 1842502** 500' Yellow Tracer Wire-18g

- Use tracer wire in the trench along yellow polypipe for an effective, code-compliant installation.



YELLOW BURIAL TAPE

W-R#	Description
------	-------------

- 2426050** 3" x 1000' Non-Detectable
- 2426052** 3" x 1000' *Detectable*

- Burial Tape is used 6 -8" above the pipe and tracer wire in the trench.



UNIVERSAL BRACKET FOR ANODELESS RISERS

W-R#	Description
------	-------------

- 2867050** 3/4" to 2" Riser Bracket

- Fits 3/4" - 2" anodeless risers
 - Adjustable from 6" - 10" from wall

6 - 10" Adjustable