

Start-up/Service Instructions

for use by heating contractor

VIESSMANN®

Vitodens 200-W, WB2B Series

Models WB2B 19, 26, 35

Wall-mounted, gas-fired condensing boiler

For operation with natural gas and liquid propane gas

Heating input 31 to 125 MBH

9 to 37 kW

Please file in Service Binder



VITODENS® 200-W

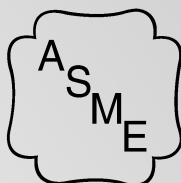
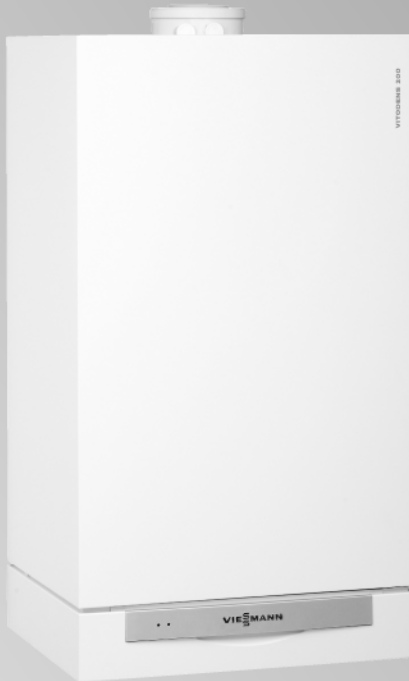

IMPORTANT

Read and save these instructions for future reference.

Safety, Installation and Warranty Requirements

Please ensure that these instructions are read and understood before commencing installation. Failure to comply with the instructions listed below and details printed in this manual can cause **product/property damage**, **severe personal injury**, and/or **loss of life**. Ensure all requirements below are understood and fulfilled (including detailed information found in manual subsections).

■ Licensed professional heating contractor

The installation, service, and maintenance of this equipment *must be performed* by a licensed professional heating contractor.

► Please see section entitled "Important Regulatory and Installation Requirements" in the Installation Instructions.

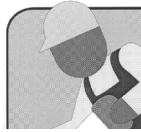

■ Carbon monoxide

Improper installation, service and/or maintenance can cause flue products to flow into living space. Flue products contain *poisonous* carbon monoxide gas.

► For information pertaining to the proper installation, service and maintenance of this equipment to avoid formation of carbon monoxide, please see the Installation Instructions of the Vitodens 200-W Direct Vent System.



■ Equipment venting

Never operate boiler without an *installed venting system*. An improper venting system can cause carbon monoxide poisoning.

■ Warranty

Information contained in this and related product documentation must be read and followed. *Failure to do so renders warranty null and void.*



■ Product documentation

Read all applicable documentation before commencing installation. Store documentation near boiler in a readily accessible location for reference in the future by service personnel.

► For a listing of applicable literature, please see section entitled "Important Regulatory and Installation Requirements" in the Installation Instructions.



WARNING

Installers must follow local regulations with respect to installation of carbon monoxide detectors. Follow manufacturer's maintenance schedule of boiler.

■ Advice to owner

Once the installation work is complete, the heating contractor must familiarize the system operator/ultimate owner with all equipment, as well as safety precautions/requirements, shut-down procedure, and the need for professional service annually before the heating season begins.

Warning

This boiler requires fresh air for safe operation and **must** be installed with provisions for adequate combustion and ventilation air (in accordance with local codes and regulations of authorities having jurisdiction).

Do not operate this boiler in areas with contaminated combustion air. High levels of contaminants such as dust, lint or chemicals can be found at construction sites, home renovations, in garages, workshops, in dry cleaning/laundry facilities, near swimming pools and in manufacturing facilities.

Contaminated combustion air **will damage** the boiler and may lead to substantial property damage, severe personal injury and/or loss of life. Ensure boiler/burner is inspected and serviced by a qualified heating contractor at least once a year in accordance with the Start-up/Service Instructions of the boiler.

Operating and Service Documentation

It is recommended that all product documentation such as parts lists, operating and service instructions be handed over to the system user for storage. Documentation is to be stored near boiler in a readily accessible location for reference by service personnel.

General Information	Safety, Installation and Warranty Requirements	2
	Operating and Service Documentation	2
	Important Regulatory and Installation Requirements	4
	About these Start-up/Service Instructions	6
	Necessary Tools	6
	Applicability	7
	Product Information	7
	Mechanical Room	8
	Removing Front Enclosure Panel	9
Initial Start-up and Service	Steps	11
Control Technology	Outdoor Reset Programming Unit (Votronic 200, HO1)	26
Coding	Coding Level 1	37
	Coding Level 2	40
Service Scans	Service Level Overview	50
	Temperatures, Boiler Coding Card and Brief Scans	51
	Checking Outputs (Relay Test)	52
	Scanning Operating Conditions and Sensors	53
Troubleshooting	Diagnostics	54
	Corrective Action	60
Additional Information	Control Functions	64
	Burner Program Sequence of Operation	67
	Wiring Diagrams	68
	Parts Lists	70
	Maintenance Record	73
	Technical Data	74
	Lighting and Operating Instructions	76

Important Regulatory and Installation Requirements

Codes

The installation of this unit shall be in accordance with local codes or, in the absence of local codes, use CAN/CSA-B149.1 or .2 Installation Codes for Gas Burning Appliances for Canada. For U.S. installations use the National Fuel Gas Code ANSI Z223.1. Always use latest editions of codes.

In Canada all electrical wiring is to be done in accordance with the latest edition of CSA C22.1 Part 1 and/or local codes. In the U.S. use the National Electrical Code ANSI/NFPA 70. The heating contractor must also comply with both the Standard for Controls and Safety Devices for Automatically Fired Boilers, ANSI/ASME CSD-1, and the Installation Code for Hydronic Heating Systems, CSA B214-01, where required by the authority having jurisdiction.

Instructing the system user

The installer of the system is responsible to ensure the system operator/ultimate owner is made familiar with the system functioning, its activation, and its shut-down.

Initial start-up

Initial start-up must be performed by a qualified heating contractor. Proper completion of the Maintenance Record by the heating contractor is also required.

Working on the equipment

The installation, adjustment, service, and maintenance of this boiler must be done by a **licensed professional heating contractor** who is qualified and experienced in the installation, service, and maintenance of hot water boilers. **There are no user serviceable parts on the boiler, burners, or control.**

Ensure **main power** supply to equipment, the heating system, and all external controls has been **deactivated**. **Close main gas supply valve.** Take precautions in all instances to avoid accidental activation of power during service work.

Technical literature

Literature for the Vitodens boiler:

- Technical Data Manual
- Installation Instructions
- Start-up/Service Instructions
- Operating Instructions and User's Information Manual
- Instructions of other Viessmann products utilized and installed
- Installation codes mentioned in this manual

→ *The following topics must be covered:*

*Proper system operation sequence.
Explain the equipment.
Demonstrate an emergency shut-down, what to do and what not.
Explain that there is no substitute for proper maintenance to help ensure safe operation.*

→ *The Maintenance Record is located on page 73 of this manual.*

→ *Please carefully read this manual prior to attempting start-up, maintenance or service. Any warranty is null and void if these instructions are not followed.*

For information regarding other Viessmann System Technology componentry, please reference documentation of the respective product.

We offer frequent installation and service seminars to familiarize our partners with our products. Please inquire.

→ *The completeness and functionality of field supplied electrical controls and components must be verified by the heating contractor. These include low water cut-offs, flow switches (if used), staging controls, pumps, motorized valves, air vents, thermostats, etc.*

→ *Leave all literature at the installation site and advise the system operator/ultimate owner where the literature can be found. Contact Viessmann for additional copies.*

→ *This product comes with several safety instruction labels attached. Do not remove!
Contact Viessmann immediately if replacement labels are required.*

Important Regulatory and Installation Requirements *(continued)*

For installations on the Commonwealth of Massachusetts, the following modifications to NFPA-54 chapter 10 apply:
Excerpt from 248 CMR 5-08:

- 2(a) For all side-wall horizontally vented gas fueled equipment installed in every dwelling, building or structure used in whole or in part for residential purposes, including those owned or operated by the Commonwealth and where the side-wall exhaust vent termination is less than (7) feet above finished grade in the area of the venting, including but not limited to decks and porches, the following requirements shall be satisfied:
1. **INSTALLATION OF CARBON MONOXIDE DETECTORS.** At the time of installation of the side-wall horizontal vented gas fueled equipment, the installing plumber or gasfitter shall observe that a hard wired carbon monoxide detector with an alarm and battery back-up is installed on the floor level where the gas equipment is to be installed. In addition, the installing plumber or gasfitter shall observe that a battery operated or hard wired carbon monoxide detector with an alarm is installed on each additional level of the dwelling, building or structure served by the side-wall horizontal vented gas fueled equipment. It shall be the responsibility of the property owner to secure the services of qualified licensed professional for the installation of hard-wired carbon monoxide detectors.
 - a. In the event that the side-wall horizontally vented gas fueled equipment is installed in a crawl space or an attic, the hard-wired carbon monoxide detector with alarm and battery back-up may be installed on the next adjacent floor level.
 - b. In the event that the requirements of this subdivision can not be met at the time of completion of installation, the owner shall have a period of thirty (30) days to comply with the above requirements; provided, however, that during said thirty (30) day period, a battery operated carbon monoxide detector with an alarm shall be installed.
 2. **APPROVED CARBON MONOXIDE DETECTORS.** Each carbon monoxide detector as required in accordance with the above provisions shall comply with NFPA 720 and be ANSI/UL 2034 listed and IAS certified.
 3. **SIGNAGE.** A metal or plastic identification plate shall be permanently mounted to the exterior of the building at a minimum height of eight (8) feet above grade directly in line with the exhaust vent terminal for the horizontally vented gas fueled heating appliance or equipment. The sign shall read, in print size no less than one-half (1/2) inch in size, "GAS VENT DIRECTLY BELOW. KEEP CLEAR OF ALL OBSTRUCTIONS".
 4. **INSPECTION.** The state or local gas inspector of the side-wall horizontally vented gas fueled equipment shall not approve the installation unless, upon inspection, the inspector observes carbon monoxide detectors and signage installed in accordance with the provisions of 248 CMR 5.08(2)(a) 1 through 4.
- (b) **EXEMPTIONS:** The following equipment is exempt from 248 CMR 5.08(2)(a) 1 through 4:
1. The equipment listed in Chapter 10 entitled "Equipment Not Required To Be Vented" in the most current edition of NFPA 54 as adopted by the Board; and
 2. Product Approved side-wall horizontally vented gas fueled equipment installed in a room or structure separate from the dwelling, building or structure used in whole or in part for residential purposes.

CSD-1 Field Testing of High Limit Switches for Vitodens boilers - where required by law.

VISSMANN IS NOT RESPONSIBLE FOR ANY DAMAGES THAT THE FOLLOWING TEST PROCEDURE MAY RESULT IN BY OVERHEATING THE SYSTEM.

The Vitodens 100/200 boilers are equipped with flow switches that when activated disable or enable the burner to operate. The fixed high limit, when tripped, produces a fault that will require manual reset of the boiler control.

Fixed High Limit fault simulation method #1:

- Close the boiler valve and jump the flow switch.
- Run the boiler at high fire and it will shut down by the coding card (in WB2B models, set coding address 06 to max.) but should continue to stack the boiler temp until the fixed high limit is tripped.
- Once the fixed high limit is tripped, slowly open the boiler valve to safely cool the boiler down.

Fixed High Limit fault simulation method #2:

- Throttle the boiler valve to a point where the burner will run with as little flow as possible.
- Run the boiler to high fire via relays test.
- When the burner shuts down on the electronic limit, close the ball valve to stop the flow.
- The boiler temp should continue to stack to trip the fixed high limit.
- Once the fixed high limit is tripped, slowly open the boiler valve to safely cool the boiler down.

Fixed High Limit fault simulation method #3:

- Remove one of the wires connected to limit switch, this will produce a fault in the boilers control that requires manual reset.

About these Start-up/Service Instructions

 Take note of all symbols and notations intended to draw attention to potential hazards or important product information. These include "WARNING", "CAUTION", and "IMPORTANT". See below.

 **WARNING**
Indicates an imminently hazardous situation which, if not avoided, could result in death, serious injury or substantial product/property damage.

→ Warnings draw your attention to the presence of potential hazards or important product information.

 **CAUTION**
Indicates an imminently hazardous situation which, if not avoided, may result in minor injury or product/property damage.

→ Cautions draw your attention to the presence of potential hazards or important product information.

IMPORTANT

→ Helpful hints for installation, operation or maintenance which pertain to the product.

→

→ This symbol indicates that additional, pertinent information is to be found in column three.



→ This symbol indicates that other instructions must be referenced.

Necessary Tools

Special items

- Approved leak detection fluid for natural gas and liquid propane gas
- Pipe joint sealant

Testing/analysis equipment

- Multimeter to measure 0 - 230V, 0 - 12A AC and 0 - 100 μ A DC
- Flue gas analyzer to measure % CO₂ or O₂ (i.e. Bacharach fluid samplers or suitable electronic analyzer)
- Manometer to measure gas pressure 0 to 11 "w.c. (accurately) and up to 28 "w.c. gas pressure (or a non-electric Magnehelic® manometer may also be utilized)
- Stack thermometer 0 to 500°F / 0 to 260°C
- Bacharach calculator or suitable tables to calculate efficiency
- Carbon monoxide measuring equipment 0 to 400 ppm

→ Use only calibrated equipment.

Cleaning supplies

- Plastic hand brush
- Rags

Applicability

CAUTION

The boiler serial number must be provided when ordering replacement parts. Some replacement parts are not reverse compatible with previous versions of the Vitodens 200-W WB2B boiler.

IMPORTANT

When ordering replacement parts, provide either the 16-digit boiler serial number (on the bar code label) or the 12-digit ASME/NB serial number, located as shown underneath boiler front enclosure panel. Refer to page 9 for instructions on how to remove front enclosure panel.

Model No. WB2B 19

Serial No. 7374863

Model No. WB2B 26

Serial No. 7374864

Model No. WB2B 35

Serial No. 7374865

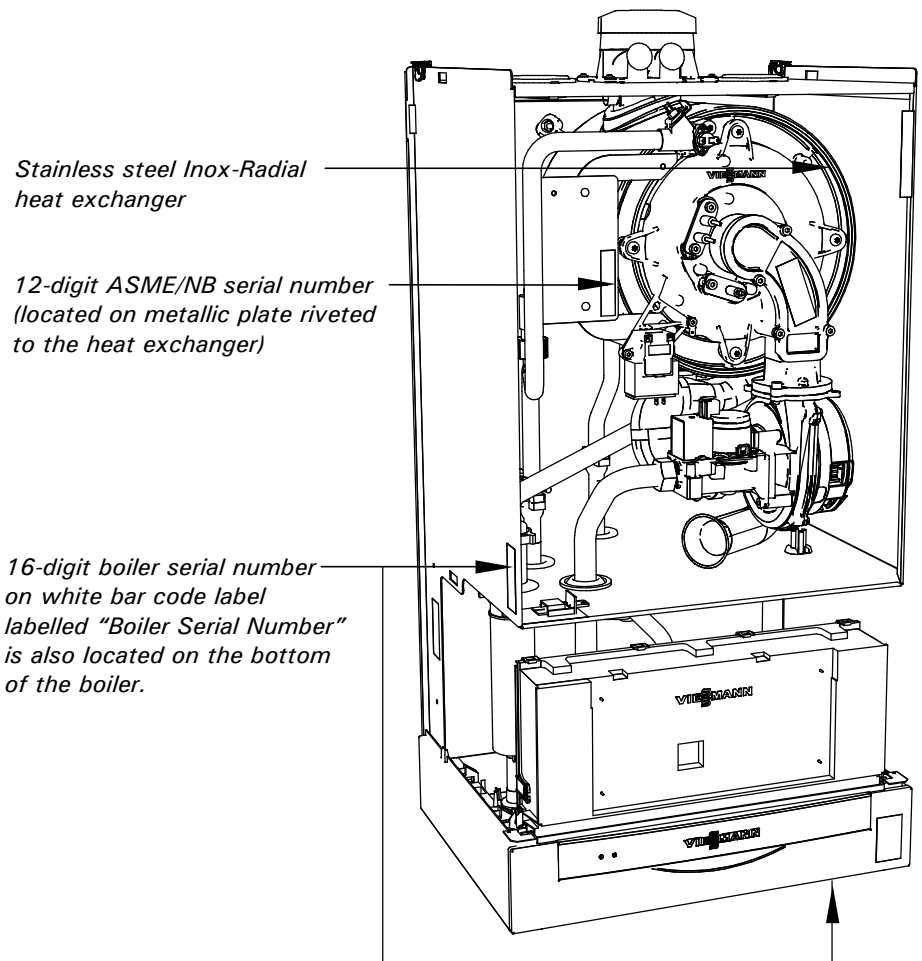

Fig. 1 Locating boiler serial numbers for ordering replacement parts

Product Information

Natural gas and liquid propane gas-fired wall-mounted condensing heating boiler for weather-responsive operation in closed loop, forced circulation hot water heating systems for space heating and domestic hot water (DHW) production.

The Vitodens 200-W, WB2B series boiler comes factory set for operation with natural gas. For a fuel conversion to liquid propane gas no conversion kit is required (see page 14).

Boiler model must be selected based on an accurate heat loss calculation of the building. Ensure boiler model is compatible with connected radiation.

Vitodens 200-W, WB2B series boilers are factory-tested and calibrated. Further gas valve adjustments are not typically required during field start-up.



Follow the Vitodens Venting System Installation Instructions to vent this boiler.

Mechanical Room

During the early stages of designing a new home, we recommend that proper consideration be given to constructing a separate mechanical room dedicated to the gas- or oil-fired heating equipment and domestic hot water storage tank(s).

The boiler must be located in a heated indoor area, near a floor drain, and as close as possible to a wall. Whenever possible, install the boiler near an outside wall so that it is easy to duct the venting system to the boiler.

Locate the boiler on a wall capable of supporting the weight of the boiler filled with water (see section entitled "Technical Data" on page 74 for information required for total boiler weight calculation). Ensure that the boiler location does not interfere with the proper circulation of combustion and ventilation air of other fuel burning equipment within the mechanical room (if applicable).

The maximum room temperature of the mechanical room where the boiler is located must not exceed 104°F / 40°C.

Installation area conditions

WARNING

Incorrect ambient conditions can lead to damage to the heating system and put safe operation at risk.

- Ensure ambient temperatures are higher than 32°F / 0°C and lower than 104°F / 40°C.
- Prevent the air from becoming contaminated by halogenated hydrocarbons (e.g. as contained in paint solvents or cleaning fluids) and excessive dust (e.g. through grinding or polishing work). Combustion air for the heating process, and ventilation of the boiler room must be free of corrosive contaminants. To that end, any boiler must be installed in an area that has no chemical exposure. The list to the right indicates the main, currently known sources.
- Avoid continuously high levels of humidity (e.g. through frequent drying of laundry).
- Never close existing ventilation openings.

WARNING

If you notice fire coming from the appliance, call the fire department immediately! Do not attempt to extinguish the fire unless qualified to do so.

WARNING

Fire causes a risk of burns and explosion!

- Shut down the boiler
- Close fuel shut-off valves
- Use a tested fire extinguisher, class ABC.

Sources of combustion and ventilation air contaminants

Areas likely to contain contaminants:

- New building construction
- Swimming pools
- Remodelling areas, hobby rooms
- Garages with workshops
- Furniture refinishing areas
- Dry cleaning/laundry areas and establishments
- Auto body shops
- Refrigeration repair shops
- Metal fabrication plants
- Plastic manufacturing plants
- Photo processing plants
- Beauty salons

Products containing contaminants:

- Chlorine-type bleaches, detergents and cleaning solvents found in household laundry rooms
- Paint and varnish removers
- Hydrochloric acid, muriatic acid
- Chlorine-based swimming pool chemicals
- Spray cans containing chlorofluorocarbons
- Chlorinated waxes and cleaners
- Cements and glues
- Refrigerant leaks
- Calcium chloride used for thawing
- Sodium chloride used for water softening salt
- Permanent wave solutions
- Adhesives used to fasten building products and other similar items
- Antistatic fabric softeners used in clothes dryers

Boiler operation in marine environments (damp, salty coastal areas)

IMPORTANT

The service life of the boiler's exposed metallic surfaces, such as the casing and fan housing, is directly influenced by proximity to damp and salty marine environments. In such areas, higher concentration levels of chlorides from sea spray, coupled with relative humidity, can lead to degradation of the exposed metallic surfaces mentioned above. Therefore, it is imperative that boilers installed in such environments **not** be installed using direct vent systems which draw outdoor air for combustion. Such boilers must be installed using room air dependent vent systems; i.e. using room air for combustion. The indoor air will have a much lower relative humidity and, hence, potential corrosion will be minimized.

Removing Front Enclosure Panel

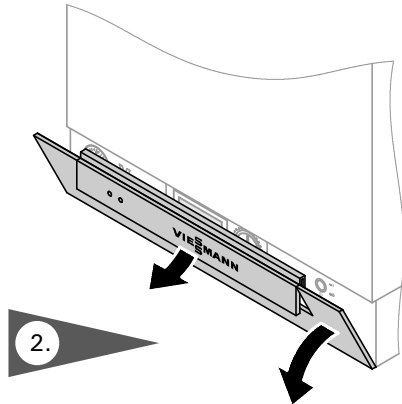

Fig. 2 Accessing the control to switch off the boiler

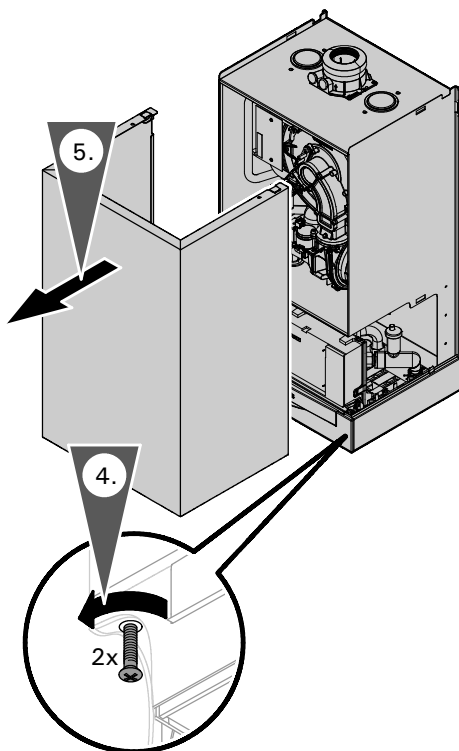

Fig. 3 Removing front enclosure panel

Some of the following start-up/service steps require the removal of the front enclosure panel. To avoid personal injury and/or product damage of any kind please follow the instructions below carefully when removing the front enclosure panel.

1. Close main gas supply valve.
2. Access the control unit by lifting and pivoting the control cover and switch off system on/off switch.
3. Turn off power supply to boiler and ensure that power supply cannot be activated during the duration of the start-up/service work.
4. Loosen the screws at the bottom of the boiler as shown (do not remove completely).
5. Slide out and remove front enclosure panel .

Steps

Initial start-up

1. Bleed air from boiler heat exchanger

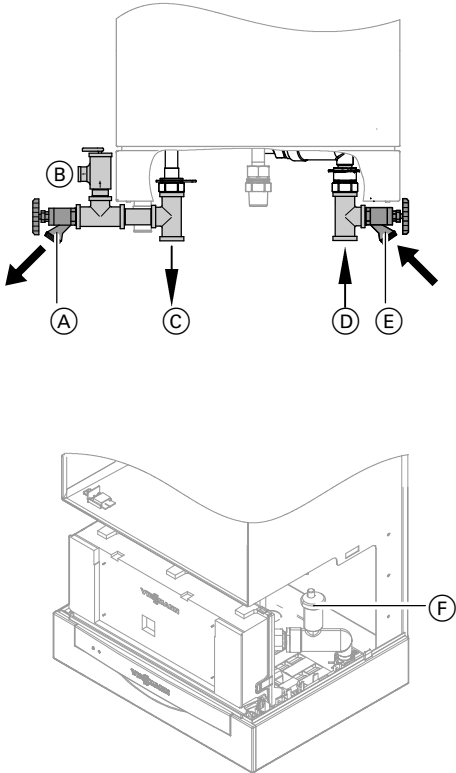

Fig. 4

(F) Automatic air vent

1. Connect hose to boiler filling tap (E) and other end to a fresh water supply (or heating medium).
2. Open fresh water supply valve and then the boiler filling tap (E) slowly (isolation valves connected to (C) and (D) must be closed during fill/bleed process).
3. Flush boiler heat exchanger via boiler supply and return (for at least 10 min.) until all air is removed from the boiler.
4. When drain valve (A) begins to bleed water, close boiler drain valve (A), then boiler fill valve (E) and open system isolation valves.
5. If the control unit has not been switched ON prior to filling the system, switch the control to ON, and activate the air bleed program by setting coding address "2F" to "1" (boiler pump [20] will be switch ON and OFF for 30 sec. at a time over a period of 20 minutes. The program is automatically disabled after 20 minutes, and coding address "2F" is set back to "0").
6. Check system pressure.
7. Ensure adequate fuel supply exists and open gas shutoff valve.

→ To access coding level 1 and setting the coding address see page 37. For function and sequence of the air bleed program, see page 65. While the air bleed program is running, the display will show "Entlüftung" (bleeding air).

→ Max. operating pressure...45 psig
Min. operating pressure...14 to 23 psig
Pressure relief valve.....30 psig

Initial start-up

2. Fill siphon with water

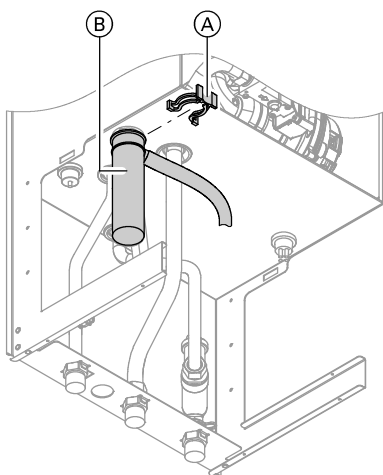

1. Remove retaining clip (A) and siphon (B).
2. Fill siphon (B) with water.
3. Re-attach siphon (B) and secure with retaining clip (A).

Steps *(continued)*

Initial start-up

3. Fill heating system with water

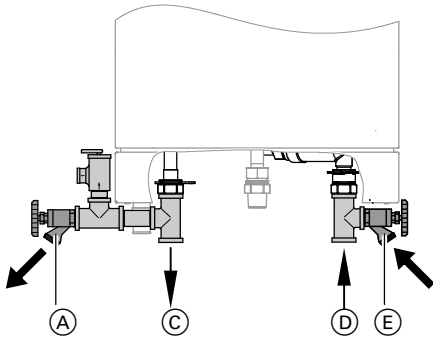

Fig. 5

- Ⓒ System supply
Ⓓ System return

CAUTION

Unsuitable fill water increases the level of deposits and corrosion, and may lead to damage to the equipment.

- Thoroughly flush the entire heating system prior to filling with water.
- Only use water of potable quality.
- The water will have to be softened if it is harder than 8.77 grains / 150 ppm total dissolved solids.
- Inhibitors or antifreeze additives suitable for heating systems may be added manually.

1. Open system isolation valves at Ⓒ and Ⓓ (if installed).

→ **Please note:**

Before filling the heating system with water, check that all necessary flow check valves are installed.

2. Check inlet pressure of the diaphragm expansion tank.

→ *If the nitrogen pressure of the precharged expansion tank is less than the static pressure of the system, inflate membrane pressure to slightly exceed pressure of system. The static pressure required at the tank is based upon the static height of the system. The system fill pressure value must be equal to the expansion tank pressure value at approx. 60°F / 15.6°C.*

3. To remove debris and/or sludge ensure that the system piping is flushed out. Failure to do so could cause settlement in the boiler causing overheating and damage not covered by warranty.

→ *System fill pressure must be approximately 3 psig higher than the static head when the system is cold.*

4. Fill the heating system with water at the boiler filling tap Ⓔ and drain air completely from the drain tap Ⓐ.

→ *Water treatment should be considered in areas where it is known that boiler feed water contains a high mineral content and hardness. In areas where freezing might occur, an antifreeze may be added to the system water to protect the system. Please adhere to the specifications given by the antifreeze manufacturer. Do not use automotive silicate-based antifreeze. Please observe that an antifreeze/water mixture may require a backflow preventer within the automatic water feed and influence components such as diaphragm expansion tanks, radiation, etc. A 40% antifreeze content will provide freeze-up protection to -10°F / -23°C. Do not use antifreeze other than specifically made for hot water heating systems. System also may contain components which might be negatively affected by antifreeze. Check total system frequently when filled with antifreeze.*

5. If the control unit has not been switched ON prior to filling the system, switch the control to ON, and activate the filling program by setting coding address "2F" to "2" (boiler pump 20 starts and the burner shuts down if this function is enabled. The program is automatically disabled after 20 minutes, and coding address "2F" is set back to "0").

→ *Max. operating pressure...45 psig
Min. operating pressure...14 to 23 psig
Pressure relief valve.....30 psig*

Steps *(continued)*

Initial start-up

4. Check power supply connection

A power/pump module is supplied with the Vitodens 200-W, WB2B boiler, which requires a 120VAC power supply from a wall receptacle. The module contains a 120/230VAC step-up transformer to power the boiler with 230VAC. Refer to the Installation Instructions shipped with the module for wiring details and/or the Installation Instructions of the boiler.

Voltage range

The voltage at connector 40 of the boiler control must be 230V (see wiring diagram).

Neutral conductor

The electrical power supply must have a neutral conductor.

IMPORTANT

In Canada all electrical wiring is to be done in accordance with the latest edition of CSA C22.1 Part 1 and/or local codes. In the U.S. use the National Electrical Code ANSI/NFPA 70. The heating contractor must also comply with both the Standard for Controls and Safety Devices for Automatically Fired Boilers, ANSI, ASME CSD-1.

→ **Please note:**

The outer conductor "L" and the neutral conductor "N" must not be interchanged.

See wiring diagram on page 68 in section entitled "Additional Information".

Initial start-up

5. Set time and date

See page 26 in these instructions for an overview of controls and indicators of the boiler control.

- During commissioning or after a prolonged time not in use, it may be necessary to reset the time and date if the time flashes in the display.
- When the boiler is started up for the first time the display appears in German (factory default setting). Refer to following subsection on how to select the correct language.

→ **Please note:**

If any fault exists during the initial start-up "störung" (fault) appears on the screen. Read and record the fault. Press "i" and read the fault. "Quittieren? Ja" (acknowledge? Yes). Press "OK" then proceed with setting the time and date.



1. Press "+ / -" to adjust to the current time.
2. Press "OK" to confirm. The word "Datum" is displayed.
3. Press "+ / -" to set the current date.
4. Press "OK" to confirm.

Steps *(continued)*

Initial start-up

6. Select language

- When the boiler is started up for the first time the display appears in German (factory default setting).

1. Press “**i**”. “Heizkreis wählen” appears on display.
2. Press “**OK**” to confirm and wait for approx. 4 sec.
3. Press “**i**” again and “Außentemperatur” (outdoor temperature) is displayed.
4. Press “**⊖**” to select required language. (language can be selected at any time by pressing “**i**” then “**⊖**”).
5. Press “**OK**” to confirm your selection.

→ **Please note:**

At any time after the initial start-up, to select a language:

- with two heating circuits A1, M2
- Press “**i**”
- choose heating circuit 1 or 2 using “**+** / **⊖**”
- Press “**OK**”
- Press “**i**” again
- Press “**⊖**” until English comes up
- Press “**OK**”

- With one heating circuit
- Press “**i**”
- Press “**⊖**” until English comes up
- Press “**OK**”

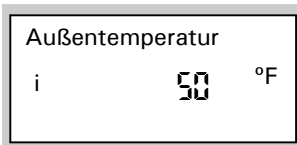

Initial start-up

7. Select gas type

- Please note that the Vitodens 200-W, WB2B boiler is factory set to operation with natural gas. See following subsection for conversion instructions to liquid propane gas.

1. Ensure that the fuel type listed on the boiler rating plate is the correct type for the installation being attempted.
2. Record fuel type in Maintenance Record on page 73.

The Vitodens 200-W boiler is for use with gases whose characteristics fall within the following ranges. Do not use any other types of gas.

		Natural gas	Liquid propane gas
Heating value (gross)	Btu/ft ³	970 to 1100	2466 to 2542
Specific gravity		0.57 to 0.70	1.522 to 1.574
Ultimate carbon dioxide (CO ₂)	%	11.7 to 12.2	13.73 to 13.82

Steps *(continued)*

Initial start-up

8. Convert fuel type to liquid propane gas

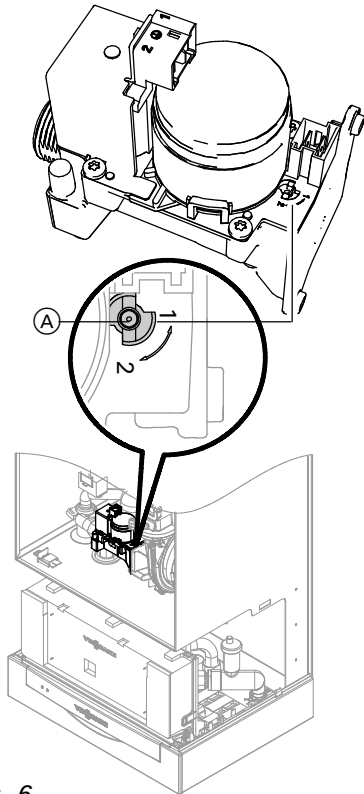

Fig. 6

1. Set adjusting screw (A) at the gas valve to "2" (using a hex key, 2.5 mm).
2. Switch ON/OFF switch "B" to ON.
3. Call up coding level 2. (see page 40)
4. In coding address "11" select value "9". The green LED flashes.
5. In coding address "82" select value "1" (operation with liquid propane gas).
6. Go back to coding address "11" and select any value (except "9")
7. Terminate coding level 2 and open gas shut-off valve.
8. Apply supplied fuel conversion labels.

→ *The Vitodens 200-W, WB2B boiler comes factory adjusted for operation with natural gas. Coding address "82" is set to "0" (operation with natural gas) in the factory default setting.*

→ **Note:**
The system automatically terminates the parameter change after approx. 25 min., if setting the parameters is not concluded via coding address 11.

Initial start-up

9. Convert to high altitude

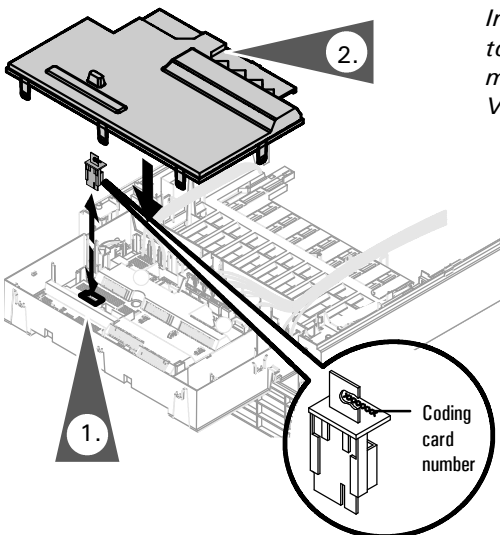

Fig. 7

In the factory default setting, the boiler is equipped to operate in altitudes of up to 5,000 ft. / 1,500 m. For operation in higher altitudes, the existing coding card must be replaced with a high altitude coding card. See table below or the Viessmann Price List for order information.

1. Pull out the factory installed coding card, cut and remove it from the cable tie. Insert the high altitude coding card into the boiler control board.
2. Install cover.

Boiler Model (base serial #)	0 - 5,000 ft. / 0 - 1,500 m	5,000 - 10,000 ft. / 1,500 - 3,000 m
WB2B 19 (7374863....)	7832 264 *1 or 7833 221 *1	7425 953 or 7424 902
WB2B 26 (7374864....)	7832 265 *1 or 7833 223 *1	7425 954 or 7424 903
WB2B 35 (7374865....)	7832 266 *1 or 7833 225 *1	7425 955 or 7424 904

*1 Factory installed

Steps *(continued)*

Initial start-up

Service

10. Measure static pressure and running pressure

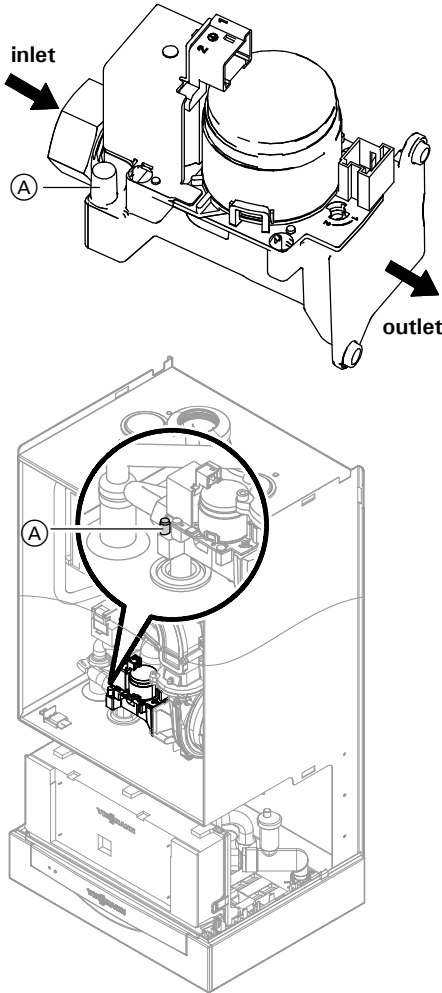

Fig. 8 Measuring gas supply pressure at inlet gas pressure port

1. To measure static and/or running pressure remove boiler enclosure panel as indicated page 9 in these instructions.
2. Close gas shutoff valve (field supplied).
3. Loosen screw at inlet gas pressure port (A) on the gas combination valve, **do not remove completely**. Connect manometer.
4. Open the gas shutoff valve.
5. Measure static pressure. Values must be:
 - 14 "w.c. max. for NG
 - 14 "w.c. max. for LPG
6. Enter measured value into Maintenance Record on page 73 in this manual.
7. Start up boiler, using the ON/OFF switch "ⓘ" on the boiler control.

IMPORTANT

A CO measurement (see page 24) must be taken before and after working on gas appliances to eliminate risks to health and to guarantee the satisfactory condition of the system.

IMPORTANT

The burner is automatically ignited and starts operation after a safety time has elapsed.

During initial start-up, the unit may indicate a fault because of air in the gas supply pipe (especially for liquid propane gas).

After approx. 5 seconds, press the "↑" button to reset the burner. The ignition procedure is repeated. This boiler employs a direct spark ignition system.

8. Measure the running pressure; value must be:

→ Use suitable measuring instruments calibrated with a minimum resolution of 0.04 "w.c. for measuring the running pressure.

Running supply pressure with		Corrective action
Natural gas	Liquid propane gas	
under 4 "w.c.	under 10 "w.c.	Do not attempt adjustment. Call local gas utility to increase pressure.
4 to 14 "w.c.	10 to 14 "w.c.	Start up boiler.
over 14 "w.c.	over 14 "w.c.	Do not attempt adjustment. Call local gas utility to decrease pressure. Boiler valve must not be exposed to pressure over 14 "w.c.

9. Enter gas type into Maintenance Record on page 73 in this manual.
10. Switch off the ON/OFF switch "ⓘ" on the boiler control, close the gas shut-off valve, remove the manometer and re-tighten the screw at inlet gas pressure port (A).

WARNING

Ensure that there is no open flame in the room.

WARNING

Never purge a gas line into a combustion chamber. Never use matches, candles, flame, or other sources of ignition for purpose of checking leakage. Use a soap-and-water solution to check for leakage. A failure to follow this warning could result in fire, explosion, personal injury, or death.

Steps *(continued)*

Sequence of operation and potential faults during each start-up cycle

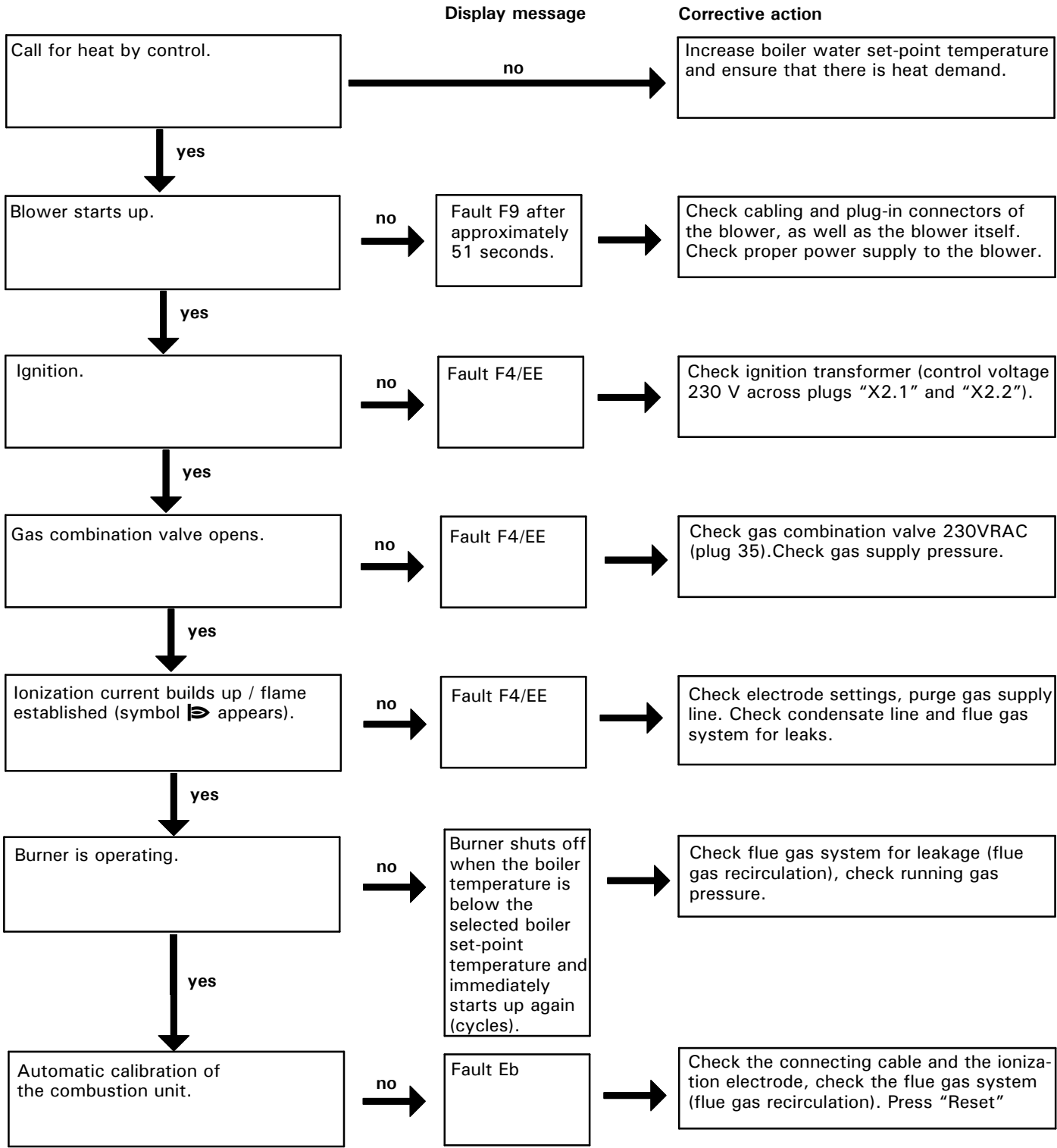

For further details regarding faults, see page 56.

Steps *(continued)*

Initial start-up

11. Set maximum input

- The maximum input (or output) for **heating operation** can be limited. The limit is set via the modulation range. The maximum adjustable heating input (or output) is limited upwards by the boiler coding card. → *The input for DHW production can be limited as well. To do so, change coding address "6F" in coding level 2.*

1. Start up boiler.
2. Press "⏻" and "🔧" simultaneously until a value flashes on the display (e.g. "85"), and "➡" and "Max. output" appear. In the factory default setting this value represents 100% of the rated input (or output).
3. With buttons "⊕ / ⊖" select the required value in % of the rated input (or output) as maximum input (or output).
4. Confirm the set value with "OK".

Initial start-up

Service

12. Check all primary and secondary circuit connections for leaks

Check heating system and domestic hot water connections (if applicable). Ensure all connections are pressure tight. Correct any leaks found on fittings, pumps, valves, etc.

Initial start-up

Service

13. Perform combustion analysis

IMPORTANT

A CO measurement (see page 24) must be taken before and after working on gas appliances to eliminate risks to health and to guarantee the satisfactory condition of the system.

Record the measured combustion values in the sequence stated in the Maintenance Record on page 73 in this manual.

Steps *(continued)*

Initial start-up

14. Check coaxial venting system for leaks (circular air gap measurement)

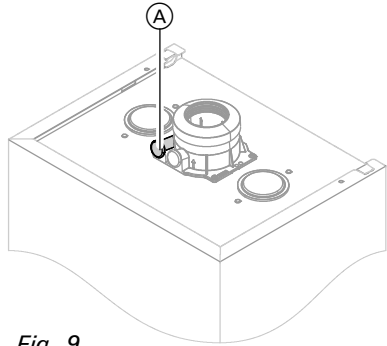

Fig. 9
 (A) Combustion air measuring port

Viessmann strongly recommends that the heating contractor perform a simplified leak test during boiler start-up. For this purpose it is sufficient to measure the CO₂ concentration of the combustion air in the coaxial gap of the air intake pipe. The vent pipe is considered sufficiently leak-proof if a CO₂ concentration in the combustion air no higher than 0.2% or an O₂ concentration no lower than 20.6% is measured. If higher CO₂ values or lower O₂ values are measured, check venting system thoroughly.

→ The vent pipe adaptor comes with two measurement ports, one for combustion air-intake measurement and one for flue gas measurement.

Service

15. Remove burner assembly

1. Switch the main power supply and the ON/OFF switch "ⓘ" on the boiler control to OFF.
2. Shut off the gas valve.
3. Pull the cables from the fan motor (A), gas valve (B), ionization electrode (C), ignition module (D) and grounding wire (E).
4. Release gas supply pipe fitting (F).
5. Loosen the four Torx (T-30) screws (G) and remove burner.

→ Note the gasket between the gas valve and the fitting.

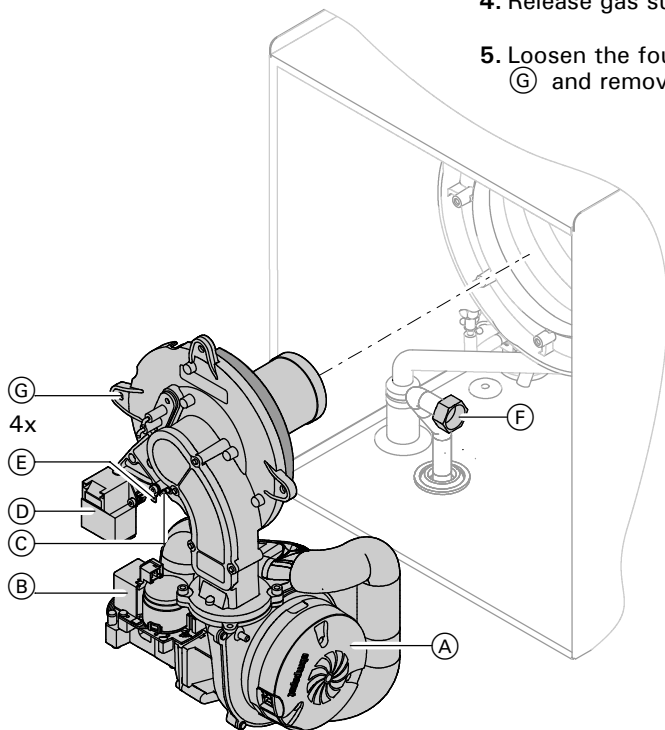

Fig. 10 Removing burner assembly

⚠ CAUTION

To avoid damage to the burner, do not lay burner on its cylindrical burner tube. Failure to heed this caution may cause damage to the burner tube, which may lead to improper operation.

Steps *(continued)*

Service

16. Check burner gasket and cylinder assembly

Check the burner gasket (A) and cylinder burner assembly (E) for damage and replace if necessary.

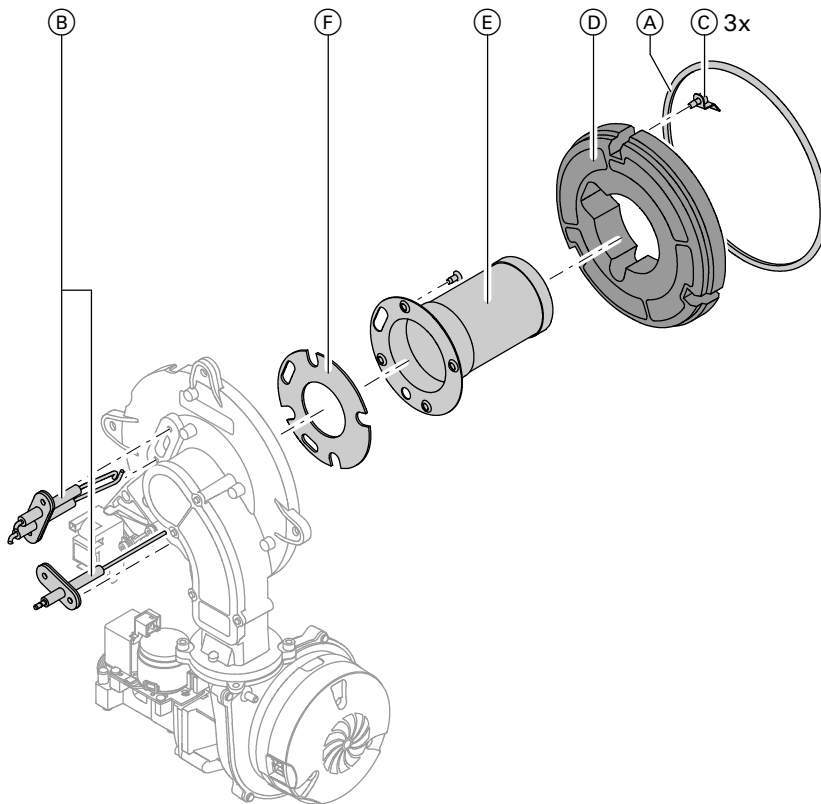

1. Remove electrode block and ionization electrode (B).
2. Undo the three retaining clips (C) at the refractory ring (D) and remove refractory ring (D).
3. Loosen the four Torx screws and remove cylinder burner assembly (E) and assembly gasket (F).
4. Fit and secure new cylinder burner assembly (E) and new assembly gasket (F). Tighten to a torque of 2.6 lb.ft. / 3.5 Nm using a calibrated torque wrench.
5. Reinstall refractory ring (D).
6. Reinstall electrode block and ionization electrode (B). Tighten to a torque of 2.6 lb.ft. / 3.5 Nm using a calibrated torque wrench.

Fig. 11 Checking burner gasket and cylinder assembly

Service

17. Check and adjust ignition and ionization electrodes

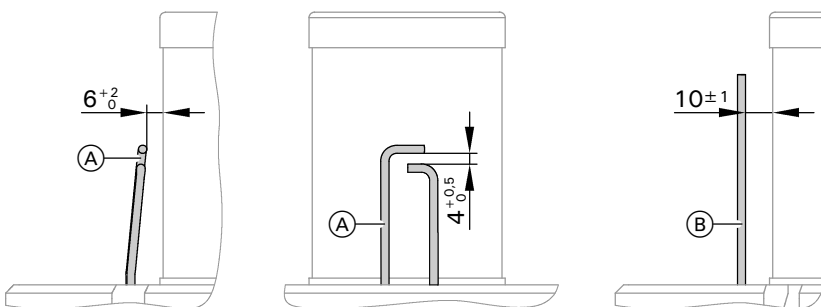

1. Check the ignition electrodes (A) and ionization electrode (B) for wear and contamination.
2. Clean electrodes with small brush (not a wire brush) or emery paper.
3. Check electrode gaps. If the gaps are not as specified, or the electrodes are damaged, replace and align the electrodes with new gaskets. Tighten the electrode fixing screws to a torque of 1.85 lb.ft. / 2.5 Nm using a calibrated torque wrench.

Steps *(continued)*

Service

18. Clean combustion chamber/heat exchanger surface

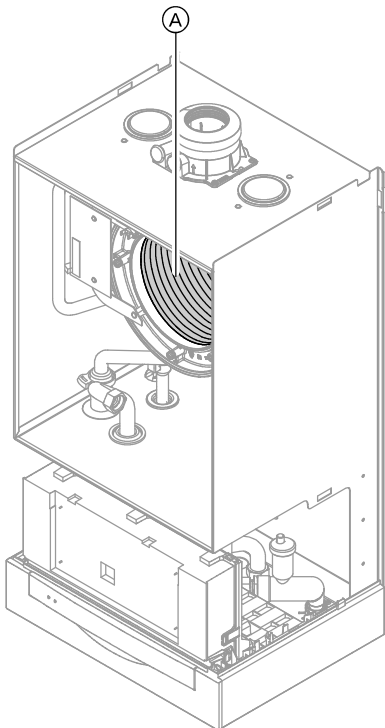

Fig. 12 *Cleaning the combustion chamber and heat exchanger*

1. Remove front enclosure panel (if still installed) as per the instructions on page 9 in this manual, and reinstall panel upon completion of service work.
2. Remove burner assembly as per instructions on page 18.
3. If necessary, clean the combustion chamber and heat exchanger surface (A) with a brush and/or rinse with water.

Use solvent-free cleaning agents to remove residues:

- Remove deposits of combustion by-products with alkaline agents containing tenside.
- Remove coatings and (yellowish brown) surface discoloration with phosphoric acid-based "Antox 75 E Plus", or citric acid-based CitriSurf™ 3050 by Stellar Solutions Inc.
- Rinse thoroughly with water.

4. Mount burner and tighten diagonally to a torque of 2.8 lb.ft. / 4 Nm (four flange locknuts).
5. Install burner assembly.
6. Fasten threaded connection for the gas connection hose with a new gasket or O-ring.
7. Connect electrical cables to corresponding parts.

→ **Please note:**

Be careful not to scratch parts which are in contact with flue gas. Use plastic brushes, not wire brushes!

Follow Material Safety Data Sheet (MSDS) of the cleaning agent manufacturer.

The cleaning agents must not contain hydrocarbon-based solvents or potassium.



WARNING

Follow cleaning agent manufacturer's safety instructions and wear appropriate protective equipment.

IMPORTANT

Perform leak test.

Steps *(continued)*

Service

19. Check condensate drain

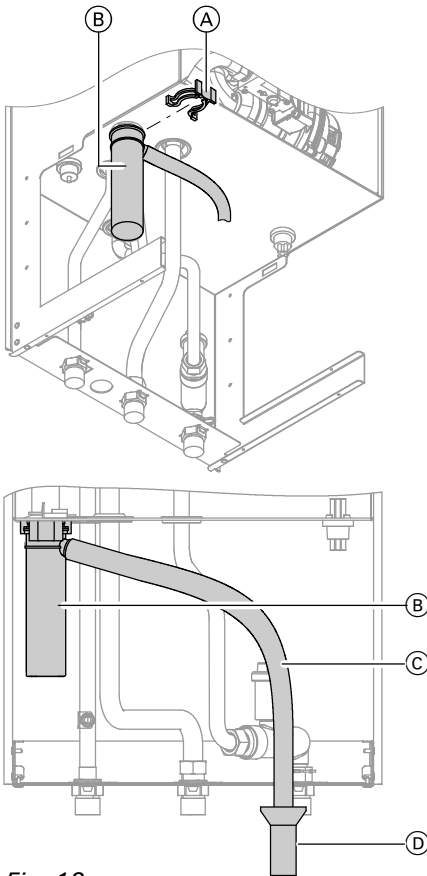

Fig. 13

- (B) Siphon trap
- (C) Flexible discharge tubing
- (D) Discharge tube

1. Check that condensate can drain freely at the siphon trap (B).
2. If necessary clean siphon trap (B) by removing retaining clip (A) and siphon trap (B).
3. After cleaning the siphon trap (B), fill it with water, re-attach it and secure with retaining clip (A).

IMPORTANT

If the condensate does not drain freely, condensate will accumulate in bottom part of boiler resulting in a burner shut-down (fault message).



*Installation Instructions
Neutralization Unit
(if applicable)*

Service

20. Check neutralization unit (if applicable)

Accessory

1. Check the pH value of the condensate with pH measuring strip. If the pH value is less than 6.5, replace granulate.
2. If contaminated:
Rinse neutralization unit with tap water.
3. Add granulate as marked.

IMPORTANT

pH measuring strip must be field supplied.

IMPORTANT

The granulate is consumed as it neutralizes the condensate. The red marking indicates the min. filling level.



*Installation Instructions
Neutralization Unit*

Steps *(continued)*

Initial start-up

Service

21. Check diaphragm expansion tank and system pressure

Perform check with the system cold.

1. Drain boiler/system and reduce pressure until the manometer reading is "0".

2. If the nitrogen pressure of the precharged expansion tank is less than the static pressure of the system, inflate membrane pressure to slightly exceed pressure of system.

The static pressure required at the tank is based upon the static height of the system. The system fill pressure value must be equal to the expansion tank pressure value at approx. 60°F / 15.6°C.

→ **Example**

Static head of 33 ft. / 10 m (distance between boiler and topmost heat emitter surface) corresponds to a static pressure of 1 bar/15 psig.

3. Top up with water until filling pressure is higher than the inlet pressure of the diaphragm expansion tank.

→ *With the system cold, the filling pressure must be approx. 3 psig higher than the static pressure. Max. operating pressure: 45 psig Min. operating pressure: 14 psig*

4. When starting up the system for the first time, mark this value as the minimum filling pressure on the manometer.

→ *A lower manometer reading usually indicates loss of water due to leakage. All leaks must be repaired.*

Initial start-up

Service

22. Check functioning of safety valves

Ensure proper operation of low water cut-off(s) (if applicable), pressure relief valve, and pump(s).

Follow local regulations with respect to backflow preventers.

Check pressure gage, air vent and pressure relief valve. Ensure that pressure relief valve does not leak and that it operates in accordance with information provided by the manufacturer.

If oil-lubricated pumps are used, ensure proper lubrication.

If motorized zone valves are used, refer to maintenance instructions provided with zone valves.

Refer to maintenance instructions supplied with low water cut-offs, pumps, etc.

Flush float water type low water cut-offs (if used).

Steps *(continued)*

I nitial start-up **S** ervice **23. Check electrical connections**

Ensure all plug-in connectors and strain reliefs make positive contact and are seated properly.



*Installation Instructions
Power/Pump Module*

I nitial start-up **S** ervice **24. Check gas pipes and fittings for leaks**

! WARNING
The gas supply piping must be leak tested before placing the boiler in operation.

! CAUTION
Ensure all joints of gas line are pressure tight and that gas valves do not leak when under normal operating pressure (use approved leak detection liquid).

Steps *(continued)*

Initial start-up

Service

25. Check CO₂ setting

Fig. 14

The Vitodens 200-W, WB2B boiler is equipped with the Lambda Pro Combustion Management System developed by Viessmann which ensures optimal combustion quality independent of gas quality and type. (For a description of the Lambda Pro Combustion Management System, see page 27 in this manual.) During initial start-up and maintenance you will only need to check the CO₂ and O₂ content at the boiler vent pipe adaptor.

Please note!

The Vitodens 200-W, WB2B boiler comes factory set to operation with natural gas. (For instructions on how to convert to operation with liquid propane gas, see page 14.) For high-altitude operation (above 5,000 ft. / 1,500 m), see page 14. The Matrix cylinder burner of this boiler is preset for the entire gas group. No adjustment or readjustment of the burner is required.

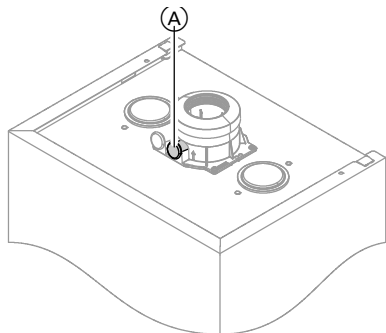
1. Connect a flue gas analyzer to test port (A) at boiler vent pipe adaptor.
2. Open gas shut-off valve, start up boiler and create heat demand.
3. Set boiler to low-fire by pressing buttons "⏻" and "OK" at the same time. "Relay test" and then "Base load" is shown on display.
4. Measure CO₂ and O₂ content at boiler vent pipe adaptor. If the measured values deviated by more than 1% from the acceptable ranges for the respective fuel type listed in the right column or in the table on page 27.
 - check the venting system for leaks (see subsection on page 18).
 - check that the boiler is set for the gas type used (see subsection on page 13).
5. Enter measured values into the Maintenance Record on page 73.
6. Set boiler to full-fire by pressing "⊕". "Full load" is displayed.
7. Measure CO₂ and O₂ content at boiler vent pipe adaptor. If the measured values deviated by more than 1% from the acceptable ranges listed in the right column or in the table on page 27.
 - check the venting system for leaks (see subsection on page 18).
 - check that the boiler is set for the gas type used (see subsection on page 13).
8. Press "OK" after testing and enter measured values into the Maintenance Record on page 73.

→ **Acceptable CO₂ content range:**

- 7.7 to 9.2% for natural gas
- 9.3 to 10.9% for LPG

Acceptable O₂ content range:

- 4.4 to 6.9% for all gas types

→ **Acceptable CO₂ content range:**

- 7.7 to 9.2% for natural gas
- 9.3 to 10.9% for LPG

Acceptable O₂ content range:

- 4.4 to 6.9% for all gas types

Steps *(continued)*

Initial start-up

Service

26. Clock natural gas meter*Clock natural gas meter to verify input.*

1. Ensure all other gas equipment served by the meter is turned off during timing of gas input to the Vitodens 200-W, WB2B boiler.
2. Measure the time in seconds it takes for the boiler to use 10 ft.³ of gas. Divide 3600 x 10 by the number of seconds and you get the number of ft.³ of gas used per hour. Multiply this number by the heating value of the gas to obtain Btu per hour input.

→ *For example:*

A Vitodens 200-W, WB2B 9-26 boiler (93 000 Btu/h input) requires 387 sec. to use 10 ft.³ of natural gas. After contacting the local utility, you will find the heating value is 1000 Btu per ft.³.

Therefore,

*3,600 sec./h x 10 revolutions
36,000/387 x 1000 ≈ 93,000 Btu/h
input. The boiler input is correct.*

Burner input formulas*(for low altitude only):**INPUT = (3600 ÷ t) x 1000 where**t = TIME (sec.) for 1 ft.³**INPUT = (3600 x .01 x 1000 x**35.31) ÷ T where**T = TIME (sec.) for .01 m³ natural gas***IMPORTANT**

A boiler underfired by 5% is acceptable. Do not overfire the boiler.

**CAUTION**

Always contact your gas utility to obtain the correct heating value before clocking the meter.

Outdoor Reset Programming Unit (Vitotronic 200, HO1)

Overview of controls and indicators

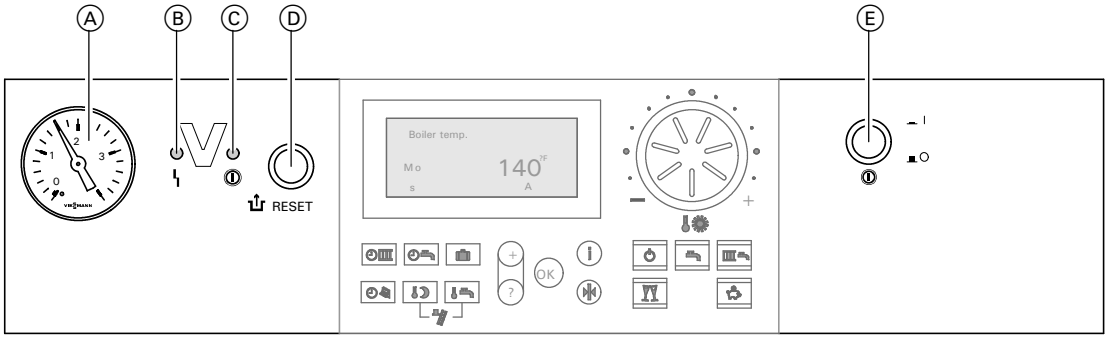

- (A) Pressure gage
- (B) Fault display (red)
- (C) Operating status display (green)
- (D) Reset button
- (E) ON / OFF switch

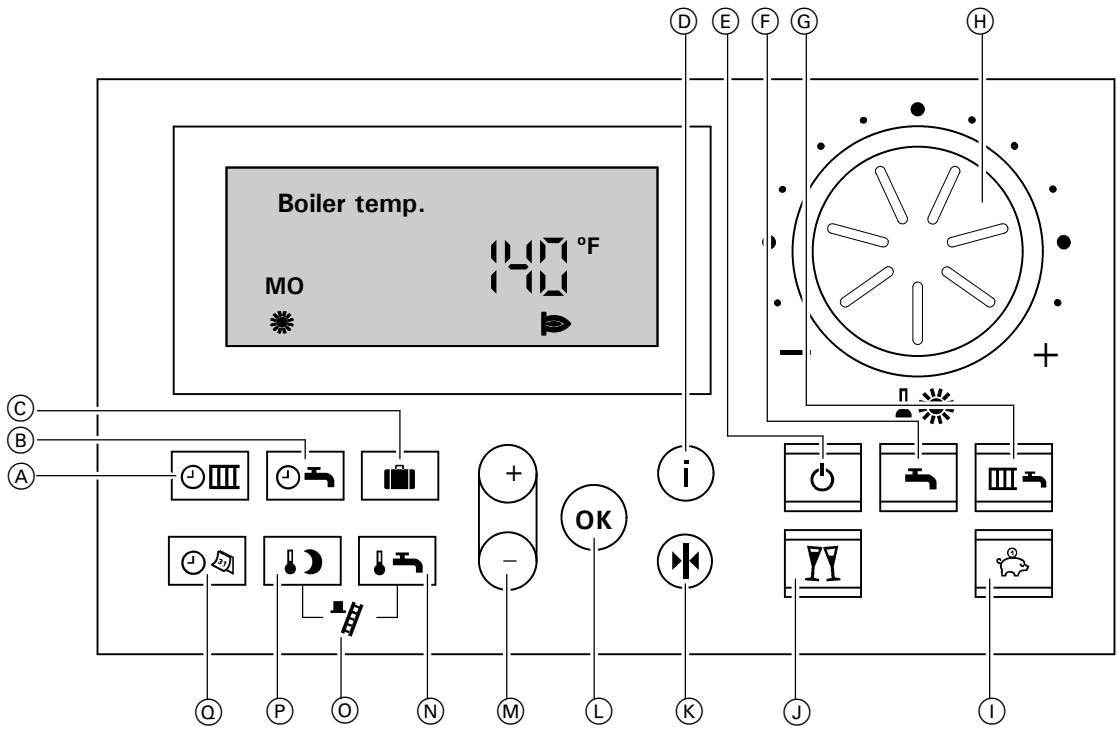

Fig. 15 Programming unit of Vitotronic 200, HO1 on-board control

- (A) Time program for central heating
- (B) Time program for DHW heating
- (C) Holiday program
- (D) Information
- (E) Standby mode
- (F) DHW only
- (G) Central heating and DHW
- (H) Normal room temperature
- (I) Energy saving mode ON / OFF
- (J) Party mode ON / OFF
- (K) Factory default settings button
- (L) Confirmation button
- (M) Adjustment buttons
- (N) DHW temperature
- (O) Emission test function (only for heating contractors)
- (P) Reduced room temperature
- (Q) Time / date

Outdoor Reset Programming Unit *(continued)*

Functional description

Space heating mode

The control unit calculates a boiler water setpoint temperature based on the outdoor or room temperature (where a room temperature dependent remote control is connected) and on the slope/shift of the heating curve. The computed boiler water setpoint temperature is transmitted to the burner control unit.

From the boiler water setpoint and the actual temperature the burner control calculates the degree of modulation required, and regulates the burner accordingly. The maximum operating boiler water temperature is limited in the burner control unit to 165°F / 74°C by the electronic temperature control. The maximum adjustable high limit of the boiler is 180°F / 82°C.

The fixed high limits of the safety chain interlock the burner control unit at 210°F / 99°C boiler water temperature.

Domestic hot water supply with gas-fired space heating boiler

Domestic hot water heating is activated when the tank temperature is 4.5°F / 2.5°C below the tank temperature setpoint value. The burner and the tank DHW pump are switched on. In the factory default setting, the desired boiler water temperature is set at 36°F / 20°C above the tank temperature setpoint value. When the actual tank temperature rises 4.5°F / 2.5°C above the tank temperature setpoint value, the burner is switched off and the time delay function of the tank DHW pump is activated.

The temperature differential of 4.5°F / 2.5°C can be adjusted in coding level 2, address "59".

DHW boost heating / additional heating function

This function will heat your DHW tank to a second DHW setpoint temperature within the fourth time phase. It can act as an "Anti-Legionnaire-Function" if the DHW supply is not heated to 140°F / 60°C during the regular time schedule. You can activate this function by selecting a switching period for the fourth time phase. (See Vitodens 200-W, WB2B Operating Instructions.) The temperature setpoint for this function is adjustable in coding address "58".

Electronic combustion control

The electronic combustion control utilizes the physical correlation between the level of the ionization current and the air factor λ . For all gas qualities, the maximum ionization current results in air factor 1.

The ionization signal is evaluated by the combustion control unit, and the air factor is adjusted to between $\lambda = 1.24$ and 1.44. This range provides for an optimum combustion quality. Thereafter, the electronic gas valve regulates the required gas volume subject to the prevailing gas quality.

To check the combustion quality, the CO₂ content or the O₂ content of the flue gas is measured. The actual values enable the prevailing air factor to be determined. The relationship between the CO₂ or O₂ content and air factor λ is illustrated in the table below.

To achieve an optimum combustion control, the system regularly carries out an automatic self-calibration; also after a power failure (shutdown). For this, the combustion is briefly regulated to the max. ionization current (equals air factor $\lambda = 1$). The automatic calibration is performed shortly after the burner starts and lasts approx. 5 sec. During the calibration, higher than normal CO emissions may occur briefly. The combustion control unit can also be calibrated manually, e.g. after maintenance or service work (see coding address "85").

Air factor λ - CO₂/O₂ content

Air factor λ	O ₂ content (%)	CO ₂ content (%) for natural gas	CO ₂ content (%) for liquid propane gas
1.24	4.4	9.2	10.9
1.27	4.9	9.0	10.6
1.30	5.3	8.7	10.3
1.34	5.7	8.5	10.0
1.37	6.1	8.3	9.8
1.40	6.5	8.1	9.6
1.44	6.9	7.8	9.3

Outdoor Reset Programming Unit *(continued)*

Heating system types

During initial start-up the control until must be matched to the type of heating system installed. In the factory default setting, the heating system type is coded as "00:1" (heating system with one heating circuit without mixing valve, without domestic hot water heating).

If a heating circuit with mixing valve is connected, for example, the control unit must be re-coded manually in coding level 1 or 2 (see page 37 on how to access coding level 1 or page 40 on how to access coding level 2). Enter corresponding heating system type code in coding address "00:1". See page 38 for codes for other system types.

See below for an overview of heating system types and corresponding codes. Refer to the Vitodens 200-W Installation Instructions for system layout details.

→ *In any of the following system layouts that use a low-loss header, the DHW tank can be installed downstream of the low-loss header. See the boiler Installation Instructions for alternative DHW connection location, as well as coding addresses "A2" and "5b" in coding level 2.*

	<p>System type 1 or 2 (with or without low-loss header)</p> <p>Heating system with one heating circuit without mixing valve, with/without domestic hot water heating</p> <p>Coding address "00:1" Without DHW heating Coding address "00:2" With DHW heating</p>
	<p>System type 3 (with or without low-loss header)</p> <p>Heating system with one heating circuit with mixing valve and system separation, with/without domestic hot water heating.</p> <p>Coding address "00:3" Without DHW heating Coding address "00:4" With DHW heating</p>

Outdoor Reset Programming Unit *(continued)*

Heating system types *(continued)*

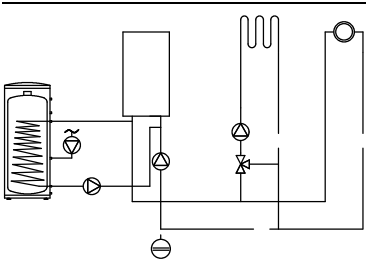
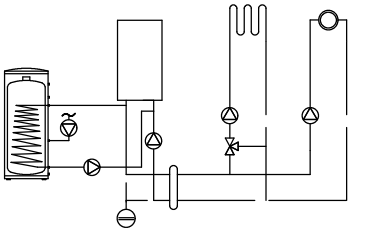
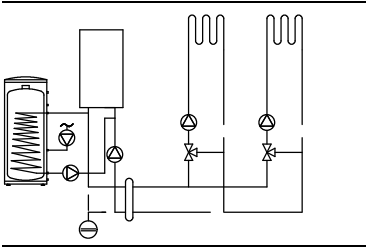
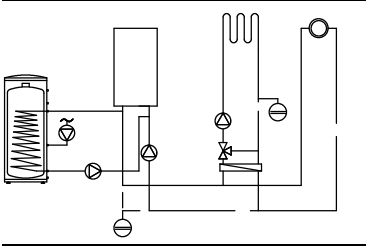
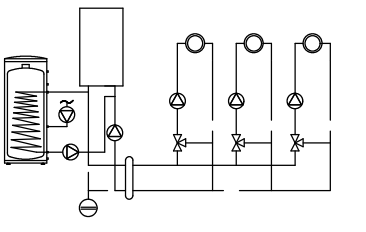
 	<p>System type 4 or 5 (with or without low-loss header)</p> <p>Heating system with one heating circuit without mixing valve, one heating circuit with mixing valve, with/without domestic hot water heating.</p> <p>Coding address "00:5" Without DHW heating Coding address "00:6" With DHW heating</p>
	<p>System type 6 (with or without low-loss header)</p> <p>Heating system with two heating circuits with mixing valve (one LON, one KM-BUS controlled), with/without domestic hot water heating.</p> <p>Coding address "00:3" Without DHW heating Coding address "00:4" With DHW heating</p>
	<p>System type 7 (with or without low-loss header)</p> <p>Heating system with one heating circuit without mixing valve, one heating circuit with mixing valve and system separation, with/without domestic hot water heating.</p> <p>Coding address "00:5" Without DHW heating Coding address "00:6" With DHW heating</p>
	<p>System type 8</p> <p>Heating system with multiple heating circuits with mixing valves, low-loss header and with/without domestic hot water heating. (two LON, one KM-BUS controlled)</p> <p>Coding address "00:3" Without DHW heating Coding address "00:4" With DHW heating</p>

Outdoor Reset Programming Unit *(continued)*

Heating curve adjustment

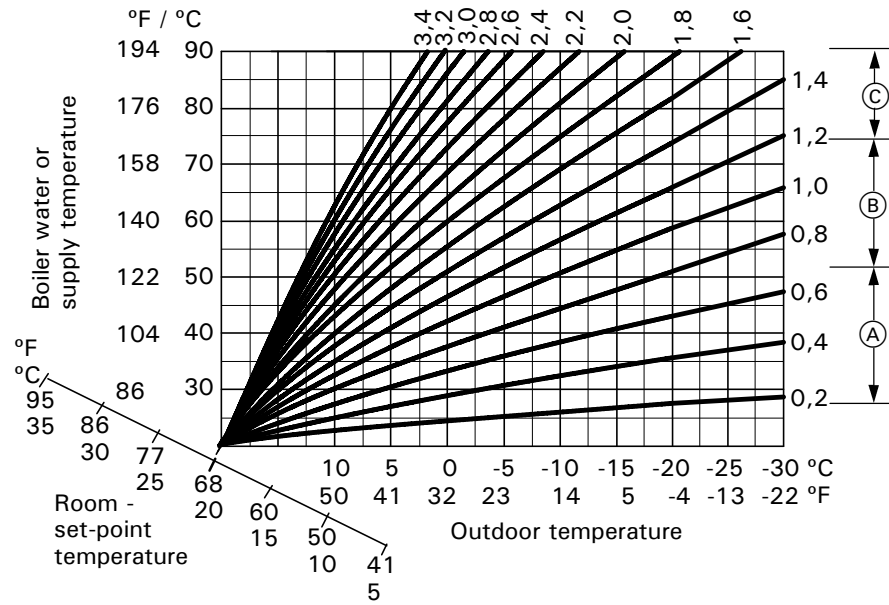

- Ⓐ Low-temperature heating system, e.g. radiant floor heating
- Ⓑ Medium-temperature heating system, e.g. cast iron radiation, staple-up radiant floor heating
- Ⓒ High-temperature heating system, e.g. fintube radiation, fan coils

The heating curves represent the relationship between the outdoor temperature and the boiler water or supply temperature. Put simply: The lower the outdoor temperature, the higher the boiler water or supply temperature. In turn, the room temperature is dependent on the boiler water or supply temperature. If a different room temperature is set, the curves are shifted parallel to the desired room temperature axis.

The control unit regulates the boiler water temperature (= supply temperature of heating circuit without mixing valve) and the supply temperature of the heating circuit with mixing valve (in conjunction with the accessory kit for a heating circuit with mixing valve) according to the outdoor temperature. The boiler water temperature is automatically raised by 0 to 72° F / 0 to 40 K higher than the currently required set supply temperature (in the factory default setting the differential temperature is 14.4° F / 8 K). See coding address "9F" in coding level 2.

The supply temperature that is required to achieve a given room temperature depends on the heating system and the thermal insulation of the building that is being heated.

The adjustment of the two heating curves is used to match the boiler water temperature and the supply temperature to these conditions. The boiler water temperature is limited upwards by the fixed high limit and the temperature set for the electronic high limit.

The supply temperature cannot rise above the boiler water temperature.

Factory settings:

- slope "1/2" = 1.4
- shift "1/2" = 0

Outdoor Reset Programming Unit *(continued)*

Heating curve adjustment *(continued)*

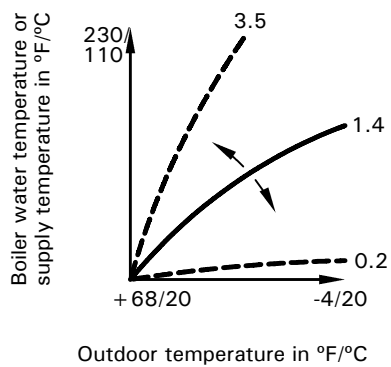

Fig. 16 Changing the slope

1. To change the slope

Change with coding address "d3" in coding level 1. Setting range 2 to 35 (equals slope 0.2 to 3.5).

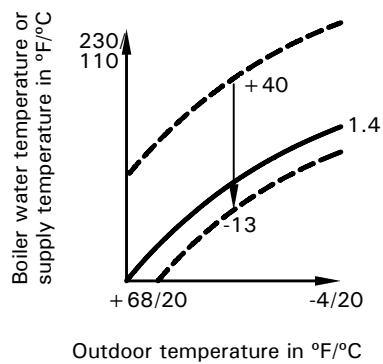

Fig. 17 Changing the shift

2. To change the shift

Change with coding address "d4" in coding level 1. Setting range -13 to +40 K.

Outdoor Reset Programming Unit *(continued)*

Room temperature setpoint adjustment

Standard Room Temperature

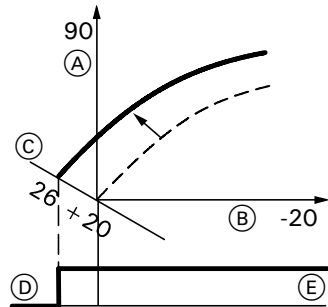

Fig. 18 Example 1: Adjusting the room temperature setpoint from 20 to 26°C

- (A) Boiler water temperature / Supply temperature in °C
- (B) Outdoor temperature in °C
- (C) Room temperature setpoint in °C
- (D) Heating circuit pump "OFF"
- (E) Heating circuit pump "ON"

1. Press "+". "1 IIII" flashes on the display.
2. Press "OK" to select a heating circuit without a mixing valve.
- or
3. Press "+". "2 IIII" flashes on the display.
4. Press "OK" to select a heating circuit with mixing valve.
5. Adjust the day temperature setpoint with rotary selector "☀️". The value will automatically be accepted after approx. 2 sec. The heating curve will be adjusted accordingly along the room temperature setpoint axis (C), which results in modified start/stop characteristics of the heating circuit pumps if the heating circuit pump logic is enabled.

Temperature conversion:

°C	°F
-20	-4
20	68
26	79
90	194

Room Temperature Setback

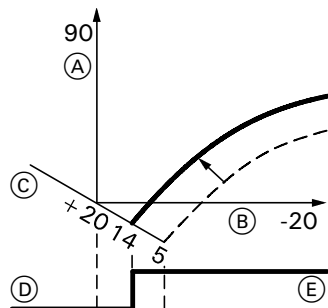

Fig. 19 Example 2: Adjusting the room temperature setback from 5 to 14°C

- (A) Boiler water temperature / Supply temperature in °C
- (B) Outdoor temperature in °C
- (C) Room temperature setpoint in °C
- (D) Heating circuit pump "OFF"
- (E) Heating circuit pump "ON"

1. Press "+". "1 IIII" flashes on the display.
2. Press "OK" to select a heating circuit without a mixing valve.
- or
3. Press "+". "2 IIII" flashes on the display.
4. Press "OK" to select a heating circuit with a mixing valve.
5. Press "🌙" for night temperature setback.
6. Press "+ / -" to change value.
7. "OK" to confirm value.

Temperature conversion:

°C	°F
-20	-4
5	41
14	57
20	68
90	194

Outdoor Reset Programming Unit *(continued)*

Connecting the boiler control to a LON system

Vitocom LON Communication Module (accessory) must be connected.



*Installation Instructions
LON Communication Module*

Note: *Data transfer via LON can take several minutes.*

Single-boiler system with Vitotronic 200-H, HK1M and Vitotronic 200-H, HK1S mixing valve controls and Vitocom LON communication module

Set up the LON participant numbers and other functions via coding level 2 (see table below).

Note: *In the same LON system, a number **cannot** be allocated twice.
Only one Vitotronic may be programmed as fault manager.*

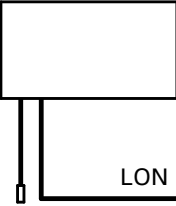
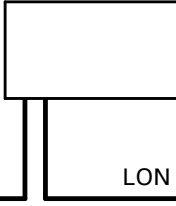
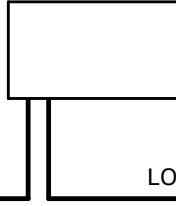
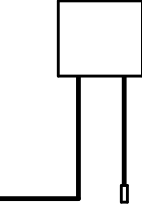
Boiler Control Unit	Vitotronic 200-H (e.g. HK1M mixing valve control)	Vitotronic 200-H (e.g. HK1S ^{*1} multiple mixing valve control)	Vitocom ^{*1} LON communication module
			
Participant no.1 Code "77:1"	Participant no.10 Code "77:10"	Participant no.11 Code "77:11"	Participant no.99
Control unit is fault manager Code "79:1"	Control unit is not fault manager Code "79:0"	Control unit is not fault manager Code "79:0"	Device is fault manager
Control unit transmits the time Code "7b:1"	Control unit receives the time Set code "81:3"	Control unit receives the time Set code "81:3"	Device receives the time
Control unit transmits outdoor temperature Set code "97:2"	Control unit receives outdoor temperature Set code "97:1"	Control unit receives outdoor temperature Set code "97:1"	--
LON participant fault monitoring Code "9C:20"	LON participant fault monitoring Code "9C:20"	LON participant fault monitoring Code "9C:20"	--

^{*1} Refer to separate Installation Instructions of accessories.

Outdoor Reset Programming Unit *(continued)*

Connecting the boiler control to a LON system *(continued)*

Updating the LON participant list

Only possible if all participants are connected and the control unit is programmed to be fault manager (coding address "79:1").

1. Press "↵" + "OK" simultaneously for approx. 2 sec. Participant check is initiated (see page 35).
2. The participant list is updated after approx. 2 min. The participant check is completed.

Outdoor Reset Programming Unit *(continued)*

Connecting the boiler control to a LON system *(continued)*

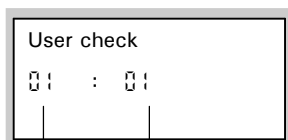

- Ⓐ Consecutive number in the participant list
- Ⓑ Participant number

Performing participant check

Conditions:

- The control unit must be programmed as fault manager (code "79:1")
- The LON participant number must be programmed in all control units (see table on previous page)
- The LON participant list in the fault manager must be up-to-date (see table on page 33)

1. Press "↵" + "OK" simultaneously for approx. 2 sec. Participant check is initiated.
2. Press "⊕ / ⊖" for required participant.
3. Press "OK". Check is enabled. "Check" flashes until its completion. The display and all key illuminations for the selected participant flash for approx. 60 sec.
4. "Check OK" is displayed during communication between both devices.

or

"Check not OK" is displayed if there is no communication between both devices. Check the LON connection.

5. Repeat steps 2 and 3 to check other participants.
6. Press "↵" + "OK" simultaneously for approx. 1 sec. The participant check is completed.

Instructing the system user

The system installer must hand the operating instructions to the system user and instruct him/her in the operation of the system.

Outdoor Reset Programming Unit *(continued)*

Scanning and resetting the "Service" display

The red fault indicator flashes when the limits for the maintenance interval (set via coding address "21") and the burner service interval (coding address "23") have been reached. On the programming unit the word "Service" flashes.

Note: Set coding address "24" to "24:0", and then to "24:1" if service is performed before the service display is shown; the set service parameters for hours run and interval are then reset to "0".

1. Press "ⓘ". The service scan is active.
2. Press "⊕ / ⊖" to scan service messages.
3. Press "ⓄK". The service display will be cleared. Reconfirm "Acknowledge: Yes" by pressing "ⓄK".
The red fault display continues to flash.

After service has been performed

1. Reset code "24:1" to "24:0".
The red fault indicator extinguishes. → If coding address "24" is not reset, the "Service" message reappears at 7 am on Monday.
2. Reset the burner hours run, burner starts and consumption, if required.
Press the following buttons:

ⓘ	Scanning is active.
⊕ / ⊖	for the selected value.
"⌘"	The selected value will be set to "0".
⊕ / ⊖	for further scans.
ⓄK	Scanning is completed.

Coding Level 1

Accessing coding level 1

Note:

- All codes are displayed as plain text.
- Codes that are irrelevant due to the system equipment level or the setting of other codes will not be displayed.
- *Heating systems with one heating circuit without mixing valve^{*1} and one heating circuit with mixing valve^{*2}:*
Initially, coding addresses "A0" to "d4" for the heating circuit without a mixing valve are scanned; then the coding addresses for the heating circuit with a mixing valve are scanned.

1. Press "⏻" + "⏮" simultaneously for approx. 2 sec.
2. Press "⊕ / ⊖" for the required coding address, the address flashes.
3. Press "ⓄK". to confirm.
4. "⊕ / ⊖" for the selected value.
5. "ⓄK". to confirm. The display briefly shows "accepted", and the address flashes again.
6. "⊕ / ⊖" to select other addresses.
7. Press "⏻" + "⏮" simultaneously for approx. 1 sec. Coding level 1 is terminated.

^{*1} May also be referred to as "heating circuit without mixer A1".

^{*2} May also be referred to as "heating circuit with mixer M2".

Coding Level 1 *(continued)*

Overview of coding addresses

Coding addresses not discussed in this section must not be changed. See page 37 for information of how to access the coding addresses in coding level 1.

Coding (factory default setting)		Possible change	
System design			
00 :1	System type 1, 2: 1 heating circuit without mixing valve, without DHW heating	00 :2	System type 1, 2: 1 heating circuit without a mixing valve, with DHW heating
		00 :3	System type 3, 6, 8: 1 heating circuit with mixing valve, without DHW heating
		00 :4	System type 3, 6, 8: 1 heating circuit with mixing valve, with DHW heating
		00 :5	System type 4, 5, 7: 1 heating circuit without mixing valve and 1 heating circuit with mixing valve, without DHW heating
		00 :6	System type 4, 5, 7: 1 heating circuit without mixing valve; 1 heating circuit with mixing valve, with DHW heating
Maximum boiler water temperature			
06:...	Maximum boiler water temperature limit (defaulted by the boiler coding card)	06:20 to 06:127	Maximum limit of the boiler water temperature within the ranges defaulted by the boiler coding card
Bleeding air/Filling			
2F:0	Air bleed program/fill program disabled	2F:1	Air bleed program enabled
		2F:2	Fill program enabled
Participant no.			
77:1	LON participant number	77:2 to 77:99	LON participant number, adjustable from 1 to 99: 1 - 4 = Boiler 5 = Cascade 10 - ... = Vitotronic 200-H, HK1S/HK1M 99 = Vitocom <i>Note: Allocate each number only once.</i>
DHW priority (heating circuit without mixing valve, A1)			
A2:2	DHW priority to heating circuit pump	A2:0	Without DHW priority to heating circuit pump
DHW priority (heating circuit with mixing valve, M2)			
A2:2	DHW priority applicable to heating circuit pump and mixing valve	A2:0	Without DHW priority applicable to heating circuit pump and mixing valve
		A2:1	DHW priority only applicable to mixing valve
		A2:3 to A2:15	Reduced priority applied to mixing valve (the heating circuit receives a reduced amount of energy)

Coding Level 1 *(continued)*

Overview of coding addresses *(continued)*













Coding (factory default setting)		Possible change	
Summer setback (econ.) A1, M2			
A5:5	With heating circuit pump logic function	A5:0	Without heating circuit pump logic function
Minimum supply temperature			
C5:20	Electronic minimum supply temperature limit 68°F / 20°C	C5:1 to C5:127	Minimum limit adjustable from 34 to 261°F / 1 to 127°C (limited by the boiler coding card). Observe max. possible boiler water temperature.
Maximum supply temperature A1, M2			
C6:74	Electronic maximum supply temperature limit 165°F / 74°C	C6:10 to C6:127	Maximum limit adjustable from 50 to 261°F / 10 to 127°C. Observe max. possible boiler water temperature of 165°F / 74°C.
Slope A1, M2			
d3:14	Heating curve slope = 1.4	d3:2 to d3:35	Heating curve slope adjustable from 0.2 to 3.5 (see page 31)
Shift A1, M2			
d4:0	Heating curve shift = 0	d4:-13 to d4:40	Heating curve shift adjustable from -13 to 40 K (see page 31)



Coding Level 2

Accessing coding level 2

Note:

- All codes are displayed as plain text.
- Codes that are irrelevant due to the system equipment level or the setting of other codes will not be displayed.

1. Press “” + “” simultaneously for approx. 2 sec.
2. Press “” to confirm.
3. Press “ / ” for the required coding address, the address flashes.
4. Press “”. to confirm.
5. “ / ” for the selected value.
6. “”. to confirm. The display briefly shows “accepted”, and the address flashes again.
7. “ / ” to select other addresses.
8. Press “” + “” simultaneously for approx. 1 sec.
Coding level 2 is terminated.

The coding addresses are grouped according to the following function areas. The respective function area is shown on the display. The areas are scanned in the following sequence by pressing “ / ”.

Function area	Coding addresses
System design	00
Boiler/Burner	06 to 54
DHW	56 to 73
General	76 to 9F
Heating circuit without mix. valve, A1	A0 to Fb
Heating circuit with mix. valve, M2	A0 to Fb

*Heating systems with one heating circuit without mixing valve*¹ and one heating circuit with mixing valve*²:*

Initially, the possible coding addresses “A0” to “Fb” for the heating circuit without a mixing valve are scanned; then the coding addresses for the heating circuit with mixing valve are scanned.

*¹ May also be referred to as “heating circuit without mixer A1”.

*² May also be referred to as “heating circuit with mixer M2”.

Coding Level 2 *(continued)*

Overview of coding addresses

Coding (factory default setting)		Possible change	
System design			
00 :1	System type 1, 2: 1 heating circuit without mixing valve, without DHW heating	00 :2	System type 1, 2: 1 heating circuit without a mixing valve, with DHW heating
		00 :3	System type 3, 6, 8: 1 heating circuit with mixing valve, without DHW heating
		00 :4	System type 3, 6, 8: 1 heating circuit with mixing valve, with DHW heating
		00 :5	System type 4, 5, 7: 1 heating circuit without mixing valve and 1 heating circuit with mixing valve, without DHW heating
		00 :6	System type 4, 5, 7: 1 heating circuit without mixing valve; 1 htg. circuit with mixing valve, with DHW heating
Boiler/Burner			
06:...	Maximum limit of the boiler water temperature, defaulted by the boiler coding card	06:20 to 06:127	Maximum limit of the boiler water temperature within the ranges defaulted by the boiler coding card
07:1	Boiler number in multiboiler system (only with Vitocontrol-S and Vitotronic 100 control)	07:2 to 07:4	Boiler number 2 to 4 in multiboiler system (only with Vitocontrol-S and Vitotronic 100 control)
11: ≠ 9	No access to the coding addresses for the parameters of the combustion controller	11:9	Access open to the coding addresses for the parameters of the combustion controller
12:0	Special function OFF Always reset to 12:0 if "possible change" used.	12:1 12:2	Special function ON: During calibration, the control automatically sets the boiler water temperature to max. If automatic calibration is initiated, the boiler will not start unless the temperature falls below 108°F / 42°C (see fault Eb before adjusting)
21:0	No maintenance interval (operating hours) selected	21:1 to 21:100	The number of hours run before the burner should be serviced is adjustable from 0 to 100 (each increment = 100 h)
23:0	No time interval for burner service selected	23:1 to 23:24	Interval adjustable from 1 to 24 months
24:0	The service display is reset	24:1	Service display (value displayed automatically)
28:0	No burner interval ignition	28:1 to 28:24	Time interval adjustable from 1 to 24 h. The burner is force-started once for 30 sec. within selected time interval (only adjustable if coding address 82:_ has been set to 1).
2E:0	KM-BUS connection of power/pump module not recognized	2E:1	KM-BUS connection of power/pump module automatically recognized
2F:0	Air bleed program/ fill program disabled	2F:1 2F:2	Air bleed program enabled Fill program enabled
32:0*1	Influence of the signal "External blocking" on circulation pumps: All pumps in control function	32:1 to 32:15	Influence of the signal "External blocking" on circulation pumps: see the following table

*1 Generally, the burner will be blocked when signal "External blocking" is enabled.

Coding Level 2 *(continued)*

Overview of coding addresses *(continued)*

Value coding address 32: ...	Boiler pump ^[20]	Heating circuit pump Heating circuit without mixing valve	Heating circuit pump Heating circuit with mixing valve	DHW circulation pump
0	Control function	Control function	Control function	Control function
1	Control function	Control function	Control function	OFF
2	Control function	Control function	OFF	Control function
3	Control function	Control function	OFF	OFF
4	Control function	OFF	Control function	Control function
5	Control function	OFF	Control function	OFF
6	Control function	OFF	OFF	Control function
7	Control function	OFF	OFF	OFF
8	OFF	Control function	Control function	Control function
9	OFF	Control function	Control function	OFF
10	OFF	Control function	OFF	Control function
11	OFF	Control function	OFF	OFF
12	OFF	OFF	Control function	Control function
13	OFF	OFF	Control function	OFF
14	OFF	OFF	OFF	Control function
15	OFF	OFF	OFF	OFF

Coding (factory default setting)		Possible change	
Boiler/Burner			
34:0	Influence of the signal "External demand" on the circulation pumps: All pumps in control function	34:1 to 34:23	Influence of the signal "External demand" on the circulation pumps: see the following table

Value coding address 34: ...	Boiler pump ^[20]	Heating circuit pump Heating circuit without mixing valve	Heating circuit pump Heating circuit with mixing valve	DHW circulation pump
0	Control function	Control function	Control function	Control function
1	Control function	Control function	Control function	OFF
2	Control function	Control function	OFF	Control function
3	Control function	Control function	OFF	OFF
4	Control function	OFF	Control function	Control function
5	Control function	OFF	Control function	OFF
6	Control function	OFF	OFF	Control function
7	Control function	OFF	OFF	OFF
8	OFF	Control function	Control function	Control function
9	OFF	Control function	Control function	OFF
10	OFF	Control function	OFF	Control function
11	OFF	Control function	OFF	OFF

Coding Level 2 *(continued)*

Overview of coding addresses *(continued)*

Value coding address 34: ...	Boiler pump [20]	Heating circuit pump Heating circuit without mixing valve	Heating circuit pump Heating circuit with mixing valve	DHW circulation pump
12	OFF	OFF	Control function	Control function
13	OFF	OFF	Control function	OFF
14	OFF	OFF	OFF	Control function
15	OFF	OFF	OFF	OFF
16	ON	Control function	Control function	Control function
17	ON	Control function	Control function	OFF
18	ON	Control function	OFF	Control function
19	ON	Control function	OFF	OFF
20	ON	OFF	Control function	Control function
21	ON	OFF	Control function	OFF
22	ON	OFF	OFF	Control function
23	ON	OFF	OFF	OFF

Coding (factory default setting)		Possible change	
Boiler/Burner			
38:0	Status burner control unit: Operational (no fault)	38: ≠ 0	Fault burner control unit
51:0	Boiler pump [20] always runs when there is a heat demand and boiler set point below warm weather shutdown. (only in conjunction with low loss header)	51:1	Boiler pump [20] will only be started when there is a heat demand (with a 60 sec. delay-off time)
52:0	Without flow temperature sensor for low-loss header	52:1	With flow temperature sensor for low-loss header (automatic recognition on connection)
53:1	No adjustment		
54:0	Without solar control unit	54:1 (not used)	With Vitosolic 100 (automatic adjustment on connection)
		54:2	With Vitosolic 200 (automatic adjustment on connection)
Domestic hot water (DHW)			
56:0	DHW temperature adjustable from 10 to 60°C	56:1	DHW temperature adjustable from 50 to above 140°F / 10 to above 60°C (max. 154°F / 68°C) Note: Maximum value subject to boiler coding card. Observe the max. permissible DHW temperature.
58:0	Without auxiliary function for DHW heating	58:10 to 58:60	Input of a second DHW setpoint, adjustable from 50 to 140°F / 10 to 60°C (observe coding address "56")
59:0	DHW tank heating (differential temperature setting): Starting point -2.5 K Stopping point +2.5 K	59:1 to 59:10	Starting point adjustable from 1 to 10 K below the setpoint

Coding Level 2 *(continued)*

Overview of coding addresses *(continued)*

Coding (factory default setting)		Possible change	
Domestic hot water (DHW)			
5b:0	DHW tank directly connected to the boiler	5b:1	DHW tank connected downstream of the low-loss header
60:20	During DHW heating, the boiler water temperature is max. 20 K higher than the DHW setpoint temperature	60:5 to 60:25	The difference between the boiler water temperature and the DHW setpoint temperature is adjustable from 5 to 25 K
62:2	Circulation pump with 2 min. time delay after DHW tank heating	62:0	Circulation pump without time delay
		62:1 to 62:15	Pump time delay adjustable from 1 to 15 min.
65:0	No adjustment		
67:40	With the Vitosolic: Third DHW setpoint temperature = 40°C (Not used.)	67:0	Without third DHW setpoint temperature
		67:1 to 67:60	Third DHW setpoint temperature adjustable from 34 to 140°F / 1 to 60°C (subject to the setting of coding address "56")
6F:100	Maximum input for DHW heating in %, defaulted by the boiler coding card	6F:5 to 6F:100	Max. input during DHW heating adjustable from 0 to 100 % (5 = min. input of the boiler). The min. to max. input range displayed is determined by the boiler coding card.
71:0	DHW recirculation pump: "ON" in accordance with the time program	71:1	"OFF" during DHW heating to the first setpoint
		71:2	"ON" during DHW heating to the first setpoint
72:0	DHW recirculation pump: "ON" in accordance with the time program	72:1	"OFF" during DHW heating to the second setpoint
		72:2	"ON" during DHW heating to the second setpoint
73:0	DHW recirculation pump: "ON" in accordance with the time program	73:1 to 73:6	During the time program "ON" 1x/hour for 5 min. up to 6x/hour for 5 min.
		73:7	Permanently "ON"
General			
76:0	Without LON communication module	76:1	With LON communication module; automatic recognition
77 :1	LON participant number	77 :2 to 77 :99	LON participant number, adjustable from 1 to 99 (see page 33). Note: <i>Allocate each number only once.</i>
79:1	With LON communication module: Control unit is fault manager	79:0	Control unit is not fault manager
7b:1	With LON communication module: The control unit transmits the time	7b:0	Do not transmit time

Coding Level 2 *(continued)*

Overview of coding addresses *(continued)*

Coding (factory default setting)		Possible change	
General			
7F:1	Detached house	7F:0	Apartment Separate adjustment of holiday program and time program for DHW heating, as option
80:1	A fault message is displayed, providing a fault is active for at least 5 sec.	80:0	Immediate fault message
		80:2 to 80:199	The fault message is issued after a delay that is adjustable from 10 sec. to 995 sec.; 1 increment = 5 sec.
81:1	Automatic daylight savings time changeover (daylight savings date in European countries)	81:0	Manual daylight savings time changeover
		81:3	Accept time via LON communication
82:0	Operation with natural gas	82:1	Operation with LPG (only adjustable if coding address 11:9 has been set).
85:0	Standard mode	85:1	Manual calibration of the combustion controller (only adjustable if coding address 11:9 has been set). The red fault indicator also flashes during calibration. The process has terminated when the red fault indicator no longer flashes (after approx. 1 min.). Note: <i>Heat generated by the boiler must be dispersed during manual calibration.</i>
88:0	Temperature displayed in °C (Celsius)	88:1	Temperature displayed in °F (Fahrenheit)
8A:175	No adjustment		
90:128	Time constant for calculating the adjusted outdoor temperature 21.3 hours	90:0 to 90:199	Fast (low values) or slow (high values) matching of the supply temperature, subject to the setpoint when the outdoor temperature changes; 1 increment = 10 min.
91:0	No external heating program changeover via connection 143 in the power/pump module (see page 64 in this manual)	91:1	The external heating program changeover affects the htg. circuit without mixing valve A1
		91:2	The external heating program changeover affects the htg. circuit with mixing valve M2
		91:3	The external heating program changeover affects the htg. circuit without mixing valve A1 and the htg. circuit with mixing valve M2
97:0	With LON communication module: The outdoor temperature of the sensor connected to the control unit is utilized internally	97:1	The control unit receives the outdoor temperature
		97:2	Control unit transmits the outdoor temperature
9b:70	Minimum boiler water temperature setpoint in case of external demand	9b:1 to 9b:127	Minimum boiler water setpoint temperature adjustable from 34 to 261 °F / 1 to 127 °C (limited by the boiler coding card)
9C:20	Monitoring LON participants When there is no response from a participant, values defaulted by the control unit are used after 20 min. and a fault message is issued	9C:0	No monitoring
		9C:0	Time adjustable from 5 to 60 min.

Coding Level 2 *(continued)*

Overview of coding addresses *(continued)*

Coding (factory default setting)		Possible change	
General			
9F:8	Differential temperature 8 K; only in conjunction with the mixing valve circuit	9F:0 to 9F:40	Differential temperature adjustable from 0 to 40 K (0 to 72°F)
Boiler circuit, mixing valve circuit			
A0:0	Without remote control	A0:1	With Vitotrol 200 (automatic recognition)
		A0:2	With Vitotrol 300 (automatic recognition)
DHW priority (heating circuit without mixing valve, A1)			
A2:2	DHW priority to heating circuit pump	A2:0	Without DHW priority to heating circuit pump
DHW priority (heating circuit with mixing valve, M2)			
A2:2	DHW priority applicable to heating circuit pump and mixing valve	A2:0	Without DHW priority applicable to heating circuit pump and mixing valve
		A2:1	DHW priority only applicable to mixing valve
		A2:3 to A2:15	Reduced priority applied to mixing valve (the heating circuit receives a reduced amount of energy)
A3:2	Outdoor temperature below 34°F / 1°C: Heating circuit pump "ON" Outdoor temperature above 37°F / 3°C: Heating circuit pump "OFF"	A3:-9 to A3:15	Heating circuit pump "ON/OFF" (see the following table)

WARNING

When selecting a value below 34°F / 1°C, there is a risk of pipes outside the thermal envelope of the building being damaged by frost. The standby mode, in particular, should be taken into consideration, e.g. during holidays.

Parameter coding address A3:...	Heating circuit pump	
	"ON" at	"OFF" at
-9	14°F / -10°C	18°F / -8°C
-8	16°F / -9°C	20°F / -7°C
-7	18°F / -8°C	21°F / -6°C
-6	20°F / -7°C	23°F / -5°C
-5	21°F / -6°C	25°F / -4°C
-4	23°F / -5°C	27°F / -3°C
-3	25°F / -4°C	28°F / -2°C
-2	27°F / -3°C	30°F / -1°C
-1	28°F / -2°C	32°F / 0°C
0	30°F / -1°C	34°F / 1°C
1	32°F / 0°C	36°F / 2°C
2 to 15	34 to 57°F / 1 to 14°C	37 to 61°F / 3 to 16°C

Coding Level 2 *(continued)*

Overview of coding addresses *(continued)*

Coding (factory default setting)		Possible change	
Boiler circuit, mixing valve circuit			
A4:0	With frost protection	A4:1	No frost protection, adjustment only possible if coding address "A3: -9" has been selected. Note: <i>Observe the note for code "A3".</i>
A5:5	With heating circuit pump logic function (economy circuit): Heating circuit pump "OFF" if the outdoor temperature (AT) is 1 K higher than the room temperature setpoint (RTset) $AT > RTset + 1 K$	A5:0	Without heating circuit pump logic function
		A5:1 to A5:15	With heating circuit pump logic function: Heating circuit pump "OFF", if (see the following table)

Parameter coding address A5:...	With heating circuit pump logic function: Heating circuit pump OFF, if
1	$AT > RTset + 5 K$
2	$AT > RTset + 4 K$
3	$AT > RTset + 3 K$
4	$AT > RTset + 2 K$
5	$AT > RTset + 1 K$
6	$AT > RTset$
7 to 15	$AT > RTset - 1 K$ to $AT > RTset - 9 K$

Coding (factory default setting)		Possible change	
Boiler circuit, mixing valve circuit			
A6:36	Extended economy function disabled	A6:5 to A6:35	Extended economy mode is enabled, i.e. the burner and heating circuit pump are switched OFF and the mixing valve will be closed at a variable value that is adjustable between 5 and 35°C plus 1°C. This value is based on the dampened outdoor temperature, comprising the actual outdoor temperature and a time constant that takes the cooling down of an average building into consideration.
A7:0	Without mixing valve economy function	A7:1	With mixing valve economy function (extended heating circuit pump logic): Heating circuit pump also "OFF" if the mixing valve was closed longer than 20 min. Heating pump "ON": <ul style="list-style-type: none"> ■ If the mixing valve changes to control mode or ■ If there is a risk of frost
A8:1	Heating circuit with mixing valve creates a demand for the circulation pump	A8:0	Heating circuit with mixing valve creates no demand for the circulation pump

Coding Level 2 *(continued)*

Overview of coding addresses *(continued)*

Coding (factory default setting)		Possible change	
Boiler circuit, mixing valve circuit			
A9:7	With pump stop function: Heating circuit pump "OFF" if the setpoint changes through a change in operating mode or through a change in the room temperature setpoint	A9:0	Without pump stop function
		A9:1 to A9:15	With pump stop function; adjustable from 1 to 15
b0:0 ^{*1}	With remote control: Heating mode / reduced mode: With outdoor reset	b0:1	Heating mode: With outdoor reset Reduced mode: With room temperature feedback
		b0:2	Heating mode: With room temperature feedback Reduced mode: With outdoor reset
		b0:3	Heating mode / reduced mode: With room temperature feedback
b1:0	Do not adjust		
b2:8 ^{*1}	With remote control unit and for heating circuit, operation with room temperature feedback must be programmed: Room influencing factor 8	b2:0	No room influence
		b2:1 to b2:31	Room influence factor adjustable from 1 to 31
b3:0	Do not adjust		
b5:0 ^{*1}	With remote control: Without room temperature dependent heating circuit pump logic function Note: ΔT = Temperature difference	b5:1	Heating circuit pump ON at $RT_{actual} > RT_{set} + \Delta T$ OFF, at $RT_{actual} < RT_{set} + \Delta T$ $\frac{\Delta T \text{ for ON}}{4K / 7F}$ $\frac{\Delta T \text{ for OFF}}{5K / 9F}$
		b5:2	3K / 5F 4K / 7F
		b5:3	2K / 4F 3K / 5F
		b5:4	1K / 2F 2K / 4F
		b5:5	0K / 0F 1K / 2F
		b5:6	-1K / -2F 0K / 0F
		b5:7	-2K / -4F -1K / -2F
		b5:8	-3K / -5F -2K / -4F
C5:20	Electronic minimum supply temperature limit 68°F / 20°C	C5:1 to C5:127	Minimum temperature limit adjustable from 34 to 261°F / 1 to 127°C (limited by the boiler coding card)
C6:74	Electronic maximum supply temperature limit 165°F / 74°C	C6:10 to C6:127	Maximum temperature limit adjustable from 50 to 261°F / 10 to 127°C (limited by the boiler coding card)
d3:14	Heating curve slope = 1.4	d3:2 to d3:35	Heating curve slope adjustable from 0.2 to 3.5 (see page 31).
d4:0	Heating curve shift = 0	d4:-13 to d4:40	Heating curve shift adjustable from -13 to 40 K (see page 31)

^{*1} Change coding – for heating circuit without mixing valve A1 only for boilers without lower temperature limit
– for heating circuit with mixing valve M2 only, if remote control unit affects this heating circuit.

Coding Level 2 *(continued)*

Overview of coding addresses *(continued)*

Coding (factory default setting)		Possible change	
Boiler circuit, mixing valve circuit			
d5:0	External heating program changeover via plug 143: Heating program changes to constant operation with reduced room temperature	d5:1	Heating program changes to constant operation with normal room temperature
E5:0	Without variable speed heating circuit pump. Do not adjust.		
F1:0	Do not adjust.		
F2:8	Time limit for party mode or external heating program changeover via keyboard: 8 hours* ²	F2:0	No time limit for party mode
		F2:1 to F2:12	Time limit adjustable from 1 to 12 hours* ¹
F5:12	Do not adjust.		
F6:25	Do not adjust.		
F7:25	Do not adjust.		
F8:-5	With outdoor temperature sensor: Below an outdoor temperature of 23°F / -5°C, the reduced room temperature setpoint is raised to an outdoor temperature dependent value according to the set heating curve (up to the temperature limit as defined in coding address "F9"). See example on page 65. Observe the setting of coding address "A3".	F8: +10 to F8:-60	Temperature limit for raising the reduced operation adjustable from 50 to -76°F / +10 to -60°C
		F8:-61	Function disabled
F9:-14	With outdoor temperature sensor: Below an outdoor temperature of 7°F / -14°C, the reduced room temperature setpoint is raised to the value of the normal room temperature setpoint. See example on page 65.	F9: +10 to F9:-60	Temperature limit for raising the reduced operation adjustable from 50 to -76°F / +10 to -60°C
FA:20	Raising the boiler water setpoint temperature or the supply setpoint temperature when changing from operation with reduced room temperature to operation with standard room temperature, by 20 %. See example on page 65.	FA:0 to FA:50	Temperature rise adjustable from 0 to 50 %
Fb:30	Duration for raising the boiler water temperature setpoint or the supply temperature setpoint (see coding address "FA") 60 min. See example on page 66.	Fb:0 to Fb:150	Duration adjustable from 0 to 300 min.; 1 increment = 2 min.

*¹ Change coding – for heating circuit without mixing valve A1 only for boilers without lower temperature limit – for heating circuit with mixing valve M2 only, if remote control unit affects this heating circuit.

*² Party mode ends automatically in heating program "III→" when the system changes over to operation with standard room temperature.

Coding Level 2 *(continued)*

Resetting coding addresses to the factory default setting

1. Press "↵" + "⏏" simultaneously for approx. 2 sec.

2. Press "⏏". "Factory set? Yes" appears.

3. Press "OK" to confirm.

or

4. "⊕ / ⊖" to select "Factory set? No".

Service Level Overview

Function	Key combination	Exit	Page
Temperatures, boiler coding card and brief scans	Press "⏏" and "⏏" simultaneously for approx. 2 sec.	Press "OK"	51
Relay test	Press "⏏" and "OK" simultaneously for approx. 2 sec.	Press "OK"	52
Max. output (heating mode)	Press "⏏" and "⏏" simultaneously for approx. 2 sec.	Press "OK"	17
Operating conditions and sensors	Press "i".	Press "OK"	53
Service scan	Press "i" (if "Service" flashes).	Press "OK"	36
Adjusting the display contrast	Press "OK" and "⊕" simultaneously; the display darkens.	--	--
	Press "OK" and "⊖" simultaneously; the display becomes lighter.	--	--
Retrieving an acknowledged fault message	Press "OK" for approx. 3 sec.	--	55
Fault history	Press "OK" and "⏏" simultaneously for approx. 2 sec.	Press "OK"	55
Participant check (in conjunction with LON)	Press "OK" and "↵" simultaneously for approx. 2 sec.	Press "OK" and "↵" simultaneously.	35
Emissions test function "⏏"	Press "⏏" and "⏏" simultaneously for approx. 2 sec.	Press "⏏" and "⏏" or "⏏" and "⏏" simultaneously for approx. 1 sec, alternatively automatic after 30 min.	--

Service Level Overview *(continued)*

Coding level 1 Plain text display	Press "⏏" and "↵" for approx. 2 sec. simultaneously.	Press "⏏" and "↵" for approx. 1 sec. simultaneously.	38
Coding level 2 Numerical display	Press "↵" and "⏏↵" for approx. 2 sec. simultaneously.	Press "↵" and "⏏↵" for approx. 1 sec. simultaneously.	40
Resetting coding addresses to the factory default setting	Press "↵" and "⏏↵" for approx. 2 sec. simultaneously; then press ↵	--	50

Temperatures, Boiler Coding Card and Brief Scans

1. Press "⏏" + "⏏↵" simultaneously for approx. 2 sec.
2. Press "⊕ / ⊖" for the required scan.
3. Press "Ⓞ" to complete the scan.

The following values can be scanned, depending on the system installed:

Display screen	Explanation
Slope A1 ^{*1} - shift A1 Slope M2 ^{*1} - shift M2 Outdoor temperature adjustment Outdoor temperature actual Boiler temperature setpoint Boiler temperature actual DHW temperature setpoint DHW temperature actual Supply temperature Supply temperature actual Common supply temperature setpoint Common supply temperature actual Boiler coding card Brief scan 1 to 8	The adjusted outdoor temperature can be reset to the actual outdoor temperature with "↵". Heating circuit with mixing valve. Heating circuit with mixing valve. Low-loss header. Low-loss header.

^{*1} A1 = Heating circuit without mixing valve. M2 = Heating circuit with mixing valve.

Brief scan	Display screen					
	0	0	0	0	0	0
1	Software version Control unit		Equipment version		Burner control unit version	
2	System designs 01 to 06		Number of KM BUS participants	Maximum heat demand temperature		
3	0	Software version Programming unit	Software version Mixing valve accessory kit 0: no mixing valve accessory kit	Software version Solar control unit (if used) 0: no solar control unit	Software version LON communication module 0: no LON communication module	Software version External extension 0: no external extension

Temperatures, Boiler Coding Card and Brief Scans *(continued)*

Brief scan	Display screen					
	0	0	0	0	0	0
4	Software version Burner control unit		Type Burner control unit		Equipment type	
5	0: no external demand 1: external demand	0: no external blocking 1: external blocking	0	External 0 to 10V hook-up Display in °C 0: no external hook-up		
6	Number of LON participants		Check digit	Max. output Details in %		
	Boiler		Heating circuit A1 (without mixing valve)		Heating circuit M2 (with mixing valve)	
7	0	0	Remote control 0: w/o 1: Vitotrol 200 2: Vitotrol 300	Software version Remote control 0: no remote control	Remote control 0: w/o 1: Vitotrol 200 2: Vitotrol 300	Software version Remote control 0: no remote control
	Circulation pump		Heating circuit pump to connection extension			
8	Variable speed pump 0: w/o	Software version Variable speed pump 0: no variable speed pump	Variable speed pump 0: w/o	Software version Variable speed pump 0: no variable speed pump	Variable speed pump 0: w/o	Software version variable speed pump 0: no variable speed pump

Checking Outputs (Relay Test)

1. Press "⏻" + "OK" simultaneously for approx. 2 sec.
2. Press "+ / -" for the required relay output.
3. Press "OK" to complete relay test.

The following relay outputs can be controlled depending on your system design:

Display screen	Explanation
Base load	Burner modulation base load (min. input)
Full load	Burner modulation full load
Boiler pump ON	External power/pump module 20
Heating circuit pump ON (M2)	Htg. circuit pump with mix. valve ext. kit
Mixing valve open	Htg. circuit pump with mix. valve ext. kit
Mixing valve closed	Htg. circuit pump with mix. valve ext. kit
Output internal ON	Not used
Heating circuit pump ON (A1)	External power/pump module 20A
DHW pump ON	External power/pump module 21
DHW recirculation pump ON	External power/pump module 28
Central fault indicator ON	External power/pump module 50

Scanning Operating Conditions and Sensors

1. Press “**i**”. “Select heating circuit” is displayed. → *If one heating circuit A1. Press “**+**” for required operating condition.*
2. Press “**OK**” to confirm. Wait approx. 4 sec.
3. Press “**i**” again.
4. Press “**+** / **-**” for required operating condition.
5. Press “**OK**” to complete scan.

Depending on the system installed, the following operating conditions can be scanned, for the heating circuit without mixing valve and the heating circuit with mixing valve:

Display screen	Explanation
Participant number	Programmed participant number in LON system
Holiday program	If a holiday program has been entered
Departure date	Date
Return date	Date
Outdoor temperature, -- °C	Actual value
Boiler temperature, -- °C	Actual value
Supply temperature, -- °C	Actual value (only for heating circuit with mixing valve, M2)
Normal room temperature, -- °C	Setpoint value
Room temperature, -- °C	Actual value
External room temperature setpoint	For external connection
DHW temperature, -- °C	Actual DHW temperature
Solar DHW temperature, -- °C	Actual value
Collector temperature, -- °C	Actual value
Common supply temperature, -- °C	Actual value, only with low-loss header
Burner, -- hr.	Actual hours run
Burner cycles,	Hours run and burner starts (reset after maintenance with “ ✱ ” to “0”)
Solar energy, -- kW/h	
Time	
Date	
Burner ON/OFF	Output 20
Circulation pump ON/OFF	Not used. Power/pump module
Internal output ON/OFF	If a heating circuit with mixing valve (M2) is installed
Heating circulation pump ON/OFF	Power/pump module
DHW pump ON/OFF	Power/pump module
Recirculation pump ON/OFF	Power/pump module
Central fault indicator ON/OFF	Power/pump module
Mixing valve OPEN/CLOSE	If an accessory kit for a heating circuit with a mixing valve is installed
Solar pump ON/OFF	If a Vitosolic is installed
Solar pump, -- hr.	Actual hours run
Various languages	The respective languages can be selected as permanent display languages with OK

Diagnosics

Fault display

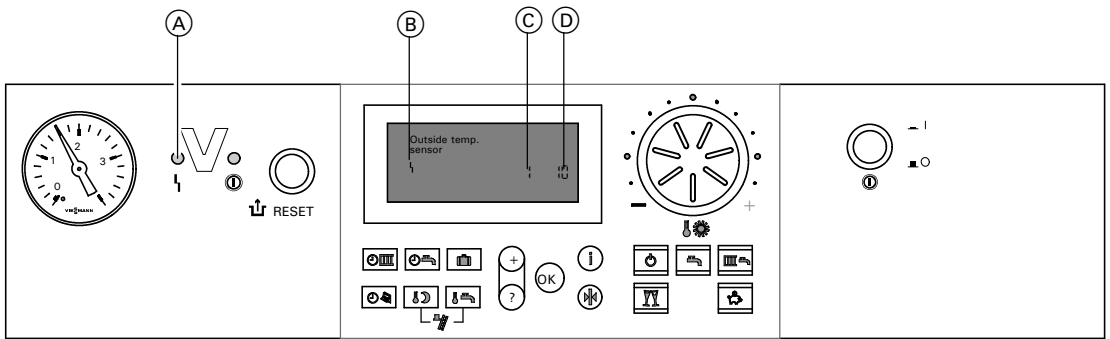

- (A) Fault display
- (B) Fault symbol
- (C) Fault number
- (D) Fault code

The red fault indicator flashes for every fault. A fault in the burner control unit causes the display to show "⚡".

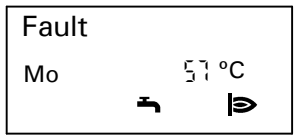

The display flashes "Fault" if a fault message is issued.

Plain text fault displays:

- Burner module
- Outdoor sensor
- Supply sensor
- Boiler sensor
- Common supply sensor (low-loss header)
- DHW sensor
- Room sensor
- Flue gas sensor
- Collector sensor
- Solar DHW sensor
- Fault participant

Checking and acknowledging faults

Note: If an acknowledged fault is not removed, the fault message will be re-displayed at 7 am the next day.

1. Press "(i)" for current fault.
2. Press "+ / -" for other fault messages.
3. Press "(OK)". All fault messages are acknowledged simultaneously, the fault display will be deleted and the red fault indicator continues to flash.

Diagnostics *(continued)*

Retrieving an acknowledged fault message

1. Press "OK" for approx. 3 sec.
2. Press "+ / -" to select the acknowledged fault.

Retrieving fault codes from the fault memory (fault history)

*The ten most recent faults are saved and can be scanned.
The faults are in order of date, so the most recent fault is fault number 1.*

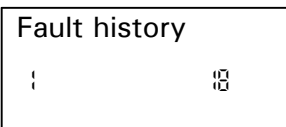

1. Press "Menu" + "OK" simultaneously for approx. 2 sec.
2. Press "+ / -" for individual fault codes.
3. **Note:** All saved fault codes can be deleted by pressing "X".
4. Press "OK" to finish scan.

Fault codes

Fault code on display	System behavior*†	Cause	Corrective action
OF	Control mode	Service	Service the equipment. After the service, reset coding address "24" to "0".
10	Boiler operates based on outdoor temperature of 32°F / 0°C	Outdoor temperature sensor shorted out	Check the outdoor temperature sensor (see page 60).
18	Boiler operates based on outdoor temperature of 32°F / 0°C	Outdoor temperature sensor cable broken	Check the outdoor temperature sensor (see page 60).
20	Regulates without supply temperature sensor (low-loss header)	System supply temperature sensor shorted out	Check the low-loss header sensor (see page 60).
28	Regulates without supply temperature sensor (low-loss header)	System supply temperature sensor cable broken	Check the low-loss header sensor (see page 60).
30	Burner blocked	Boiler water temperature sensor shorted out	Check the boiler water temperature sensor (see page 60).
38	Burner blocked	Boiler water temperature sensor cable broken	Check the boiler water temperature sensor (see page 60).

Diagnostics *(continued)*

Fault codes *(continued)*

Fault code on display	System behavior ^{*1}	Cause	Corrective action
40	Mixing valve closes	Heating circuit with mixing valve supply temperature sensor shorted out	Check the supply temperature sensor (see page 60)
48	Mixing valve closes	Heating circuit with mixing valve supply temperature sensor cable broken	Check the supply temperature sensor (see page 60)
50	No DHW heating	Tank temperature sensor shorted out	Check the sensor (see page 60)
58	No DHW heating	Tank temperature sensor cable broken	Check the sensor (see page 60)
92	Control mode	Collector temperature sensor shorted out; connects to the Vitosolic at S1	Check the sensor at the Vitosolic solar control
93	Control mode	Collector temperature sensor shorted out; connects to the Vitosolic at S3	Check the sensor at the Vitosolic solar control
94	Control mode	Collector temperature sensor shorted out; connects to the Vitosolic at S2	Check the sensor at the Vitosolic solar control
9A	Control mode	Collector temperature sensor cable broken; connects to the Vitosolic at S1	Check the sensor at the Vitosolic solar control
9b	Control mode	Tank temperature sensor cable broken; connects to the Vitosolic at S3	Check the sensor at the Vitosolic solar control
9C	Control mode	Tank temperature sensor cable broken; connects to the Vitosolic at S2	Check the sensor at the Vitosolic solar control
9F	Control mode	Solar control unit fault; displayed if a fault without fault code occurs at the solar control unit	Check the solar control unit (see solar control service instructions)
A7	Control mode (stays in factory default setting)	Faulty programming unit	Replace the programming unit
b0	Burner blocked	Flue gas temperature sensor shorted out	Check flue gas temperature sensor (see page 61)
b1	Control mode (stays in factory default setting)	Communication fault; programming unit (internal)	Check connections and replace programming unit if required
b4	Regulates as if the outdoor temperature was 0°C	Internal fault	Replace the control unit
b5	Control mode (factory default setting)	Internal fault	Replace the control unit
b7	Burner blocked	Boiler coding card missing, faulty or incorrect boiler coding card	Plug in boiler coding card or replace if faulty
b8	Burner blocked	Flue gas temperature sensor cable broken	Check flue gas temperature sensor (see page 61)

Diagnostics *(continued)*

Fault codes *(continued)*

Fault code on display	System behavior *1	Cause	Corrective action
bA	Mixing valve regulates to a supply temperature of 20°C	Communication fault - accessory kit for heating circuit with mixing valve	Check accessory kit connections and coding. Turn on the accessory kit
bC	Control mode without remote control	Communication fault - Vitotrol remote control, heating circuit without mixing valve, A1	Check connections, cable, coding address "A0" and remote control DIP switches (see page 66)
bd	Control mode without remote control	Communication fault, Vitotrol remote control, heating circuit with mixing valve, M2	Check connections, cable, coding address "A0" and remote control DIP switches (see page 66)
bE	Control mode	Vitotrol remote control incorrectly programmed	Check remote control DIP switches (see page 66)
bF	Control mode	Incorrect LON communication module	Replace LON communication module
C2	Control mode	Communication fault, solar control unit	Check connections and coding address "54"
C5	Control mode, max. pump speed (Not used)	Communication fault, variable speed circulation pump, heating circuit connection set	Check setting of coding address "30" Set to "0" 30:"0"
C7	Control mode, max. pump speed (Not used)	Communication fault, variable speed circulation pump, heating circuit without mixing valve	Check setting of coding address "E5"
Cd	Control mode (Not used)	Communication fault, Vitocom 100 (KM-BUS)	Check coding address "95" and set value to 95:0
CE	Control mode	Communication fault-power/pump module KM-BUS connection	Check connections and setting of coding address "2E"
CF	Control mode	Communication fault, LON communication module	Replace LON communication module
dA	Control mode without room influence	Room temperature sensor, heating circuit without mixing valve (A1) shorted out	Check the room temperature sensor, heating circuit without mixing valve (A1)
db	Control mode without room influence	Room temperature sensor, heating circuit with mixing valve (M2) shorted out	Check the room temperature sensor, heating circuit with mixing valve (M2)
dd	Control mode without room influence	Room temperature sensor, heating circuit without mixing valve (A1) cable broken	Check the room temperature sensor, heating circuit A1 and the remote control DIP switch settings (see page 66)
dE	Control mode without room influence	Room temperature sensor, heating circuit with mixing valve (M2) cable broken	Check the room temperature sensor, heating circuit M2 and the remote control DIP switch settings (see page 66)
E4	Burner blocked	Fault, supply voltage 24V	Replace the control unit
E5	Burner blocked	Internal fault	Check the ionization electrode and cables. Check tightness of flue gas system. Press " ⏏ RESET "









Diagnostics *(continued)*

Fault codes *(continued)*

Fault code on display	System behavior*1	Cause	Corrective action
E8	Burner in fault mode	The ionization current lies outside the permissible range	Check the ionization electrode and cable. Press "⏏RESET"
E9	Burner in fault mode	The ionization current lies outside the permissible range during calibration	Check the ionization electrode and cable. Check venting system for leaks. Press "⏏RESET"
EA	Burner in fault mode	The ionization current lies outside the permissible range during calibration	Check the ionization electrode and cable. Press "⏏RESET"
Eb	Burner blocked	Boiler control initiated a combustion calibration but could not complete the process	<ul style="list-style-type: none"> - Heat generated by boiler must be removed (boiler is cycling on temperature limits, before calibration process is complete) - Check the connecting cable and the ionization electrode, check the flue gas system (flue gas recirculation) - Verify pump operation - Switching points of flow switch marginal (not enough flow) - Check coding card - Check gas valve - Check coding address 82 - Also see address 12: __ Press "⏏RESET"
EE	Burner in fault mode	At burner start, flame signal is missing or too weak	Check the ionization electrode and cable. Check gas supply, condensate drain, ignition and ignition module Press "⏏RESET"
EF	Burner in fault mode	Flame is lost immediately after it has built (during the safety time)	Check gas supply, check flue gas/exhaust pipe/air intake for flue gas recirculation, check ionization electrode (replace if necessary) Press "⏏RESET"
EC	Burner in fault mode	The ionization current lies outside the permissible range during calibration	Check the ionization electrode and cable. Press "⏏RESET"
Ed	Burner in fault mode	Internal fault	Replace the control unit
F0	Burner blocked	Internal fault	Replace the control unit
F1	Burner in fault mode	Maximum flue gas temperature exceeded (230°F / 110°C)	Check heating system fill level. Bleed air from system. Press "⏏RESET" after vent system has cooled down

Diagnosics *(continued)*

Fault codes *(continued)*

Fault code on display	System behavior ^{*1}	Cause	Corrective action
F2	Burner in fault mode	Fixed high limit switch open (activated)	Check heating system fill level. Check the circulation pump. Bleed air from the system. Check fixed high limit switch and connecting cables. Press "  RESET "
F3	Burner in fault mode	Flame signal already present at burner start	Check the ionization electrode and connecting cable. Press "  RESET "
F4	Burner in fault mode	No flame signal	Check the ionization electrode and cable, measure the ionization current, check the gas pressure, check the gas valve, ignition, ignition module, ignition electrodes and the condensate drain. Press "  RESET "
F8	Burner in fault mode	Gas valve closes too late	Check the gas valve. Check both control wiring/connections. Press  RESET.
F9	Burner in fault mode	Fan speed too low during burner start	Check the fan, the fan cables and power supply. Check the fan control. Press  RESET
FA	Burner in fault mode	Fan not at standstill	Check the fan, the fan connecting cables and fan control. Check the fan control. Press "  RESET "
FC	Burner in fault mode	Gas valve faulty or faulty modulation valve control; or vent system blocked	Check the gas valve. Check the vent system. Press "  RESET "
Fd	Burner in fault mode	Burner control unit fault	Check ignition electrodes and connecting cables. Check whether a strong interference (EMC) field exists near the equipment. Press  RESET. Replace control unit if fault persists
FE	Burner blocked or in fault mode	Strong interference (EMC) field nearby or faulty main PCB.	Restart the equipment. Replace the control unit if the equipment will not restart
FF	Burner blocked or in fault mode	Strong interference (EMC) field nearby or faulty main PCB.	Restart the equipment. Replace the control unit if the equipment will not restart
No fault code displayed	Boiler/burner in standstill	Flow switch open	Check pump operation and flow switch

^{*1} Control mode: Boiler/burner fully operational (fault code must be verified and reset).

Burner in fault mode: Boiler control requires manual reset before burner can resume operation.

Burner blocked: If fault cause is corrected, burner resumes operation.

Corrective Action

Check outdoor temperature sensor

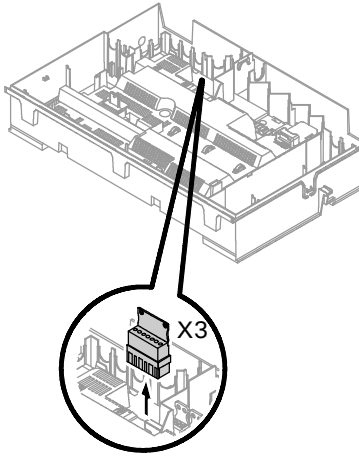
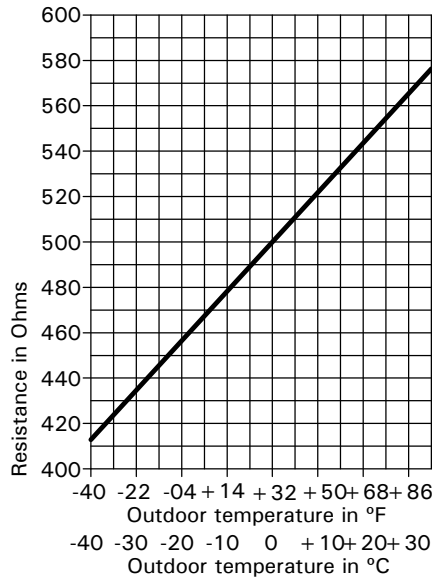

Fig. 20



1. Pull plug "X3" from the control unit.
2. Test the resistance of the outdoor temperature sensor across terminals "X3.1" and "X3.2" on the disconnected plug and compare it with the curve.
3. Where actual values strongly deviate from the curve values, disconnect the wires at the sensor and repeat test immediately at the sensor.
4. Depending on result, replace the cable or the outdoor temperature sensor.

Check boiler temperature sensor, tank temperature sensor or supply temperature sensor of the low-loss header

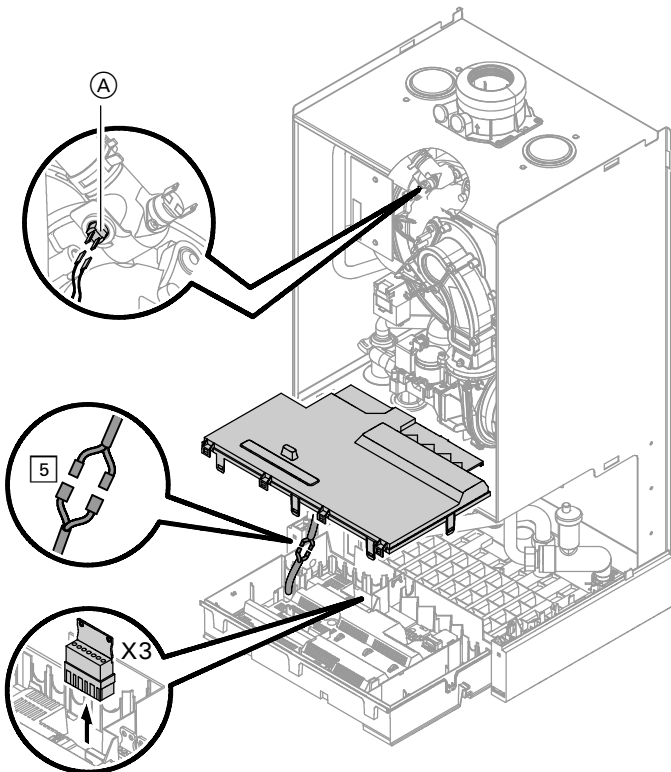

Fig. 21

1. **Boiler temperature sensor:**
Pull cables from boiler water temperature sensor (A) and check resistance.
- DHW Tank temperature sensor:**
Pull plug 5 from the cable harness at the control unit and check resistance.
- Supply temperature sensor:**
Pull plug "X3" from the control unit and check the resistance across terminals "X3.4" and "X3.5".

Continued...

Corrective Action *(continued)*

Check boiler temperature sensor, tank temperature sensor or supply temperature sensor of the low-loss header *(continued)*

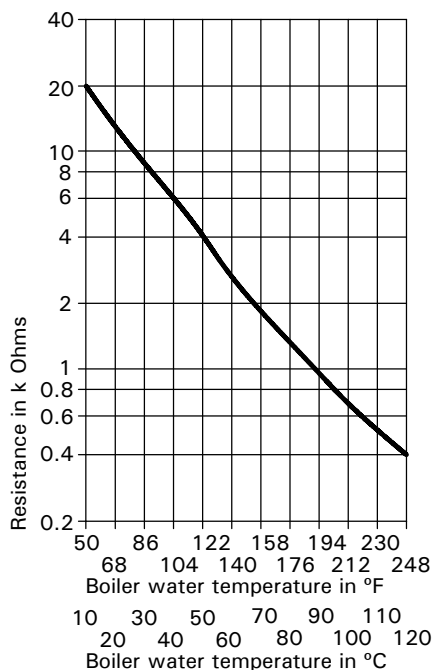

2. Check the sensor resistance and compare the actual values with the curve in the chart.
3. If the value measured differs significantly, replace sensor.

WARNING

The boiler temperature sensor is immersed in the heating water (risk of scalding). Drain the boiler before replacing the sensor.

Check flue gas temperature sensor

When exceeding the maximum permissible flue gas temperature value, the flue gas temperature sensor locks the appliance. Unlock the appliance by pressing "RESET" after the vent system has cooled down.

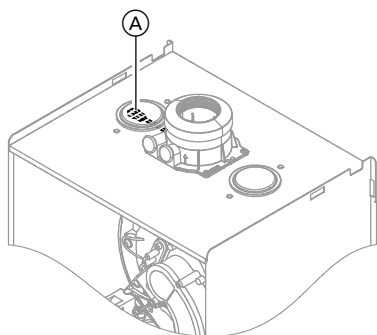
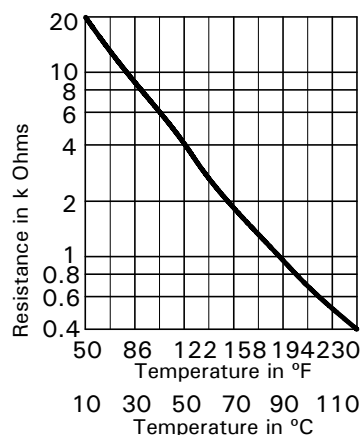

Fig. 22



1. Remove cables from flue gas temperature sensor (A).
2. Check the sensor resistance and compare the actual values with the curve in the chart.
3. Replace sensor in case of severe deviation.

Corrective Action *(continued)*

Check fixed high limit

Check the fixed high limit, if the burner control cannot be reset after a fault shutdown, although the boiler water temp. is below approx. 75°C / 167°F:

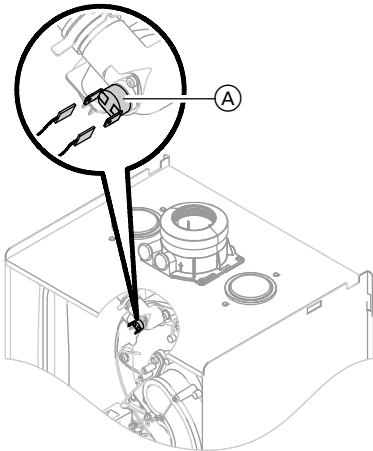



Fig. 23

1. Remove cables from the fixed high limit (A).
2. Check the continuity of the fixed high limit with a multimeter.
3. Remove and replace a defective fixed high limit.
4. After starting up the boiler, press “ RESET” on the boiler control.

Check fuse

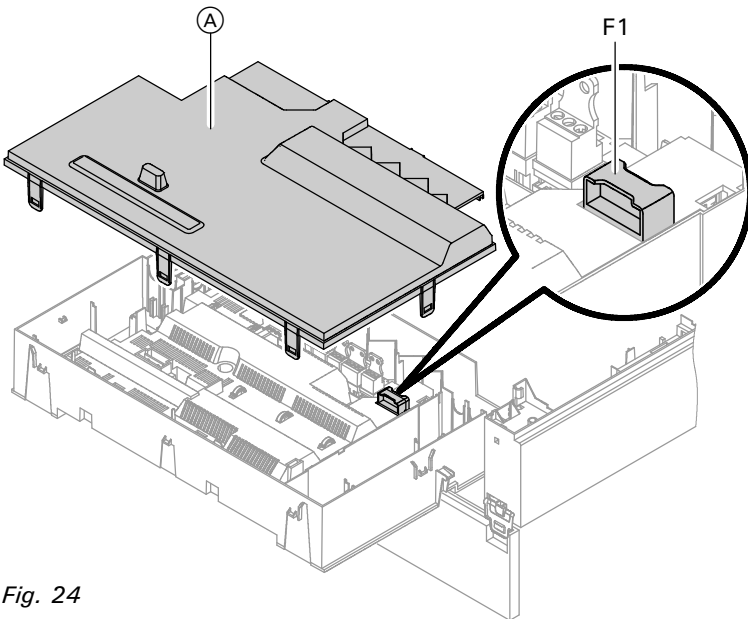

Fig. 24

1. Switch OFF the power.
2. Release side latches and pivot the control unit down.
3. Remove cover (A).
4. Check fuse F1 (see wiring diagram).

Check fuses in the power/pump module

1. Switch OFF the power.
2. Open power/pump module and check fuses F1 and F2 (see wiring diagram).

Corrective Action *(continued)*

Check accessory kit for heating circuit with mixing valve

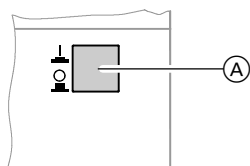

Fig. 25

Checking the rotational direction of the mixing valve motor:

1. Switch ON/OFF switch (A) at the accessory kit first OFF and then ON again. The device will perform the following self-check:
 - Mixing valve "Close" (150 sec.)
 - Pump "ON" (10 sec.)
 - Mixing valve "Open" (10 sec.)
 - Mixing valve "Close" (10 sec.)
 Then standard control mode resumes.

2. Note the rotational direction of the mixing valve motor during its self-check. Then set the mixing valve manually to "Open" again.

IMPORTANT

The supply temperature sensor must now read a higher temperature. If the temperature drops, either the motor is turning in the wrong direction or the mixing valve set is installed incorrectly.

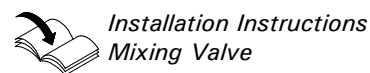

*Installation Instructions
Mixing Valve*

Changing the rotational direction of the mixing valve motor (if required):

1. Remove the lower and upper housing of the accessory kit.

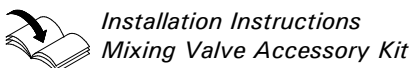

*Installation Instructions
Mixing Valve Accessory Kit*

2. Change the rotational direction switch:

Switch position I for system return from the left (factory default setting).

Switch position II for system return from the right.

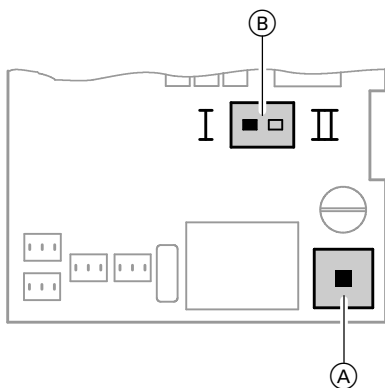

Fig. 26

- (A) ON/OFF switch
- (B) Rotational direction switch

Control Functions

External heating program changeover

The "External heating program changeover" function is connected via input "143" in the power/pump module. You can select which heating circuits the heating program changeover affects in coding address "91":

Heating program changeover	Coding
No changeover	91:0
Heating circuit without mixing valve	91:1
Heating circuit with mixing valve	91:2
Heating circuit without mixing valve and heating circuit with mixing valve	91:3

You can select which direction the heating program changeover takes in coding address "d5":

Heating program changeover	Coding
Changeover towards "Permanently reduced" or "Permanent standby" mode (based on the selected setpoint)	d5:0
Changeover towards "Constant heating mode"	d5:1

The duration of the heating program changeover can be adjusted in coding address "F2":

Heating program changeover	Coding
No changeover	F2:0
Duration of the heating program changeover 1 to 12 hours	F2:1 to F2:12

The heating program changeover stays enabled for as long as the contact remains closed, but at least as long as the duration selected in coding address "F2".

External blocking

The "External blocking" function is connected via input "143" in the power/pump module. In coding address "32", you can select the influence the "External blocking" signal should have on the connected circulation pumps.

External heat demand

The "External heat demand" function is connected via input "143" in the power/pump module. In coding address "34" you can select the influence the "External heat demand" signal should have on the connected circulation pumps. The minimum boiler water setpoint temperature in case of an external heat demand is selected in coding address "9b".

Control Functions *(continued)*

Air bleed program

During the air bleed program, the circulation pump will be alternately switched ON and OFF for 30 sec. at a time over a period of 20 min. The burner is switched OFF during the air bleed program. The program is activated via code "2F:1" and automatically disabled after 20 min. Coding address "2F" is reset to "0".

Fill program

If the system is to be filled with the control unit switched ON, code "2F:2" starts the pump. The burner shuts down if this function is enabled via coding address "2F". The program is automatically disabled after 20 min., and coding address "2F" is reset to "0".

Raising the reduced room temperature

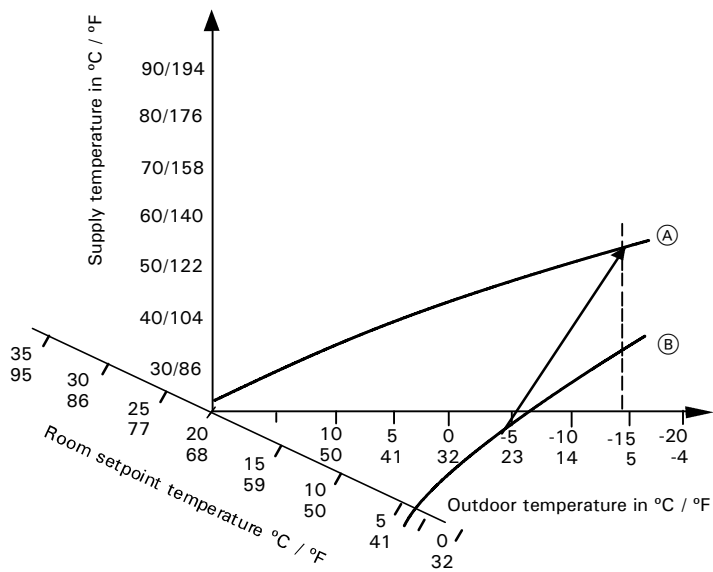

During operation with reduced room temperature, the reduced room setpoint temperature can be automatically raised based on the outdoor temperature. The temperature is raised in accordance with the selected heating curve, but no higher than the standard room temperature setpoint. The outdoor temperature limits for the start and end of the temperature raising can be adjusted via coding addresses "F8" and "F9".

Fig. 27 Example (using factory default settings)

- Ⓐ Heating curve for operation with standard room temperature
- Ⓑ Heating curve for operation with reduced room temperature

Control Functions *(continued)*

Reducing the heat-up time

During the transition from operation with reduced room temperature to operation with standard room temperature, the boiler water or supply temperature will be raised in accordance with the selected heating curve. The boiler water or supply temperature can be automatically increased. The value and duration of the additional increase of the set boiler water temperature or supply temperature can be adjusted in coding addresses "FA" and "Fb".

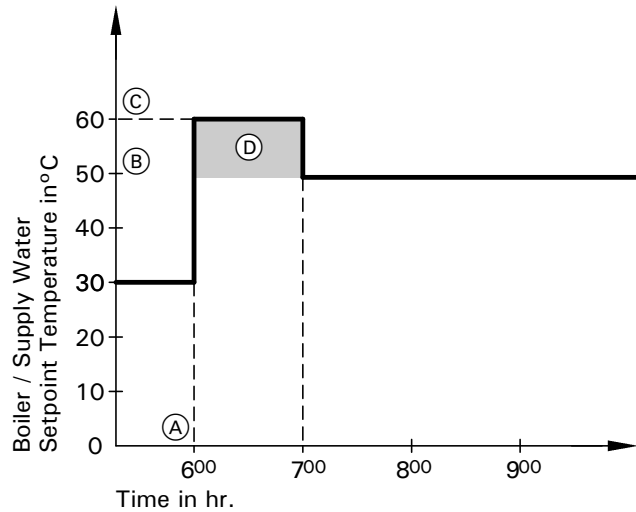

Fig. 28 Example (using factory default settings)

- Ⓐ Start of operation with standard room temperature
- Ⓑ Boiler water / supply temperature based on selected heating curve
- Ⓒ Boiler water / supply temperature based on coding address "FA":
50°C + 20 % = 60°C
- Ⓓ Duration of operation with raised boiler water / supply temperature based on coding address "Fb": 60 min.

Remote control (Vitotrol 300) DIP switch settings





Refer to Operating Instructions Vitotrol 300 Remote Control

The DIP switches are located on the PCB in the top part of the housing.

Remote control	DIP switch setting
The remote control affects the heating circuit without mixing valve (A1)	ON
The remote control affects the heating circuit with mixing valve (M2)	ON
When connecting a separate room temperature sensor, set DIP switch "3" to "ON".	ON

Burner Program Sequence of Operation

	Stand by	Stand-still status test (blower)	Pre-purge speed test	Pre-purge	Pre-ignition	Ignition / safety timing / flame stabilization	Burner modulation or calibration	Combination gas valve proof and closure test	Post-purge speed test	Additional Post-purge (if initiated)
Call for heat	Step up									
Water-flow switch closed	Step down									
Ignition					Step up					
Combination gas valve						Step up				
Flame signal						Step up		Transition		
Fan speed			Step up				Modulation range			
Fan control			Step up				Modulation range			
Modulation set point						Step up	Modulation range			
Phase	0	1	2	3	4	5	6	7	8	9
Sequence time		Normal < 1s Max. < 51s	Normal < 1s Max. < 51s	0.1s	0.4s	4.5s		Normal < 3s Max. < 15s	Normal < 3s Max. < 15s	0.15s

 Modulation range  Transition

Phase 0: Stand-by

Complete shutdown until the next call for heat. In this phase both the combination gas valve and the blower are not energized.

Phase 1: Stand-still status test (blower)

A call for heat initiates internal blower sensory communications to confirm that the blower is truly in stand-still position. Blower speed measured must be < 300 rpm within a 51 second period.

Phase 2: Pre-purge speed test

Controller sends and receives signal to / from fan speed controller to verify maximum rpm of the blower.

Phase 3: Pre-purge

Pre-purge cycle starts within the pre-programmed timing. Pre-purge timing is in addition to previous phase (2). The fan speed must be greater than and within the range of rpm requested by the controller.

Phase 4: Pre-ignition

The ignition spark is initiated and controlled.

Phase 5: Ignition / safety timing / flame stabilization

The gas valve opens during the safety timing period (4.5 secs.). If a flame is detected, this phase ends immediately in < 1.5 secs. If the flame is not established after 3 trials, the burner will lock out and will require a manual reset. Controller required time for flame stabilization.

Phase 6: Burner modulation operation or calibration

At the end of the flame stabilization period (4.5 sec.), a release for modulation occurs and the burner temperature controller will take over from the flame safeguard. Forced shutdown after 24 hours continuous operation. Automatic calibration may be initiated by the controller.

Phase 7: Combination gas valve proof of closure test

If during the normal operation of the burner a controlled (or uncontrolled) shut-down occurs, a complete mechanical and electrical gas valve proof of closure test will be performed by the flame safeguard. After a successful mechanical and electrical proof of closure test, the flame safeguard will expect that the flame is not present. If, however, the flame existed for a period of > 15 seconds, the flame safeguard will go into permanent lock-out.

Phase 8: Post-purge speed test

Both gas valves are closed during this phase. End call for heat. Post-purge occurs during the programmed period.

Phase 9: Additional post-purge

If the fixed high limit trips during normal operation, the blower will purge for 15 minutes to cool the heat exchanger.

Wiring Diagram

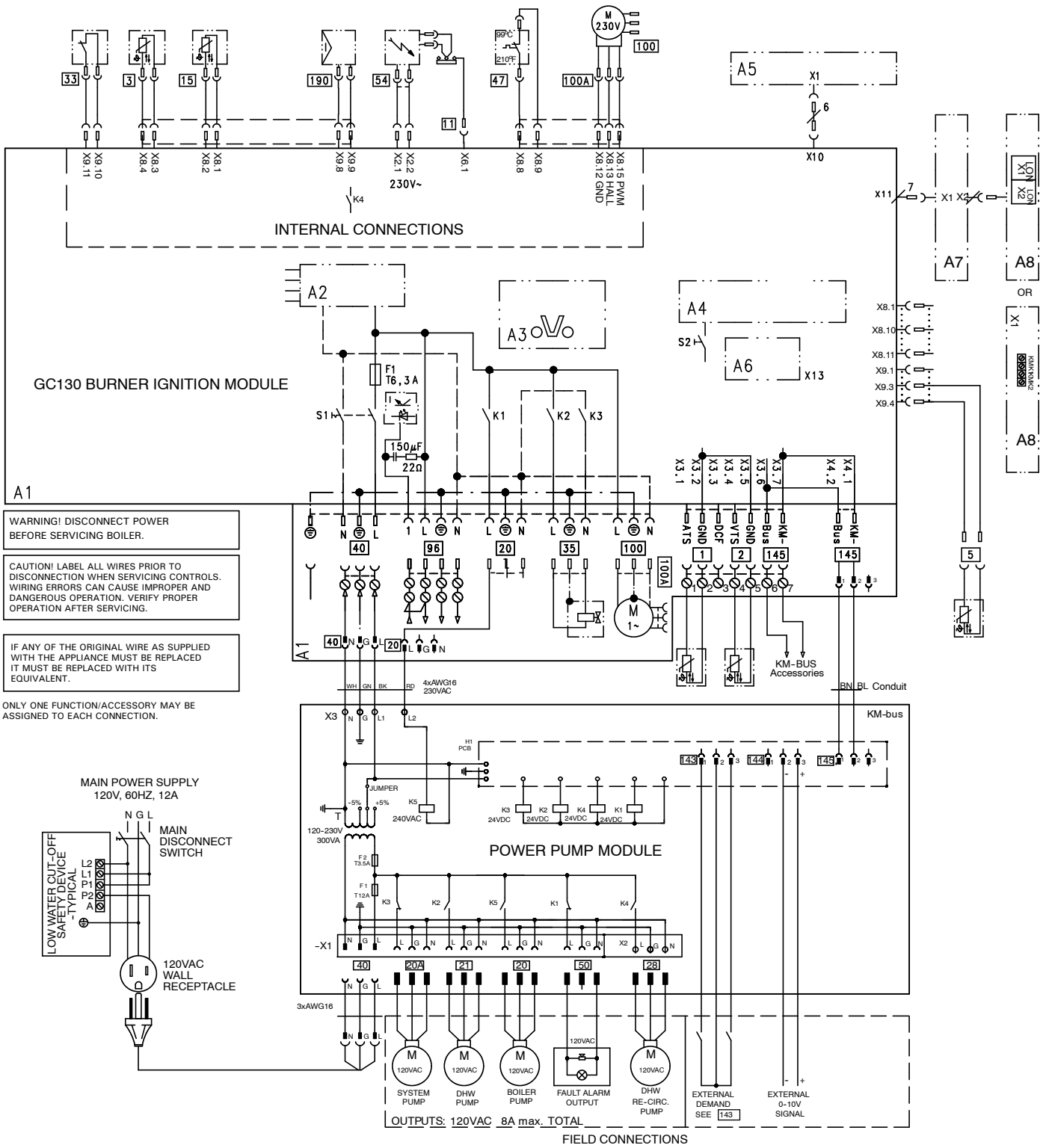

See legend for this wiring diagram on next page.

Wiring Diagram *(continued)*

Legend

- | | | |
|---|--|--|
| <ul style="list-style-type: none"> 1 Outside Temperature Sensor 2 Flow Temperature Sensor/Low Loss Header 3 Boiler Water Temperature Sensor 5 DHW Temperature Sensor 11 Ionization Electrode 15 Flue Gas Temperature Sensor 20 Boiler Pump 20A System Pump 21 DHW Pump 28 DHW Re-circulation Pump 33 Flow Switch 35 Gas Valve 40 Power Supply | <ul style="list-style-type: none"> 47 Fixed High Limit 50 Fault Alarm Output 54 Ignition Transformer 96 Power Supply Accessory (Not Used) 100 Fan Motor 100A Fan Motor Control 143 External Blocking Terminals 2-3
External Demand Terminals 1-2
External Heating Program Changeover
Terminals 1-2
The Allocation of the Function "External
Heating Program Changeover" is Set
Via Coding Address '91' 144 External 0-10V Signal 145 KM BUS to PPM/Accessories 190 Gas Modulation Coil | <ul style="list-style-type: none"> A1 Main PCB (GC130 Ignition Module) A2 Internal Power Supply Unit A3 Optolink A4 Burner Control Unit A5 Programming Unit A6 Coding Card A7 Connection Adapter A8 LON/Cascade Communication Module S1 ON/OFF Switch S2 Reset Button X.. Electrical Interfaces |
|---|--|--|

BK	BLACK
WH	WHITE
G	GREEN
RD	RED
GY	GREEN/YELLOW
BN	BROWN
BL	BLUE

Parts Lists

Ordering Replacement Parts:

Please provide model no. from rating plate (A) and serial no. when ordering replacement parts. Order replacement components from your Viessmann distributor.

Parts

- 019 Gas connection pipe
- 028 Front panel
- 029 Mounting clip
(set of 2)
- 050 Burner gasket, 187 x 5.5mm
- 051 Combustion chamber door refractory
- 052 Burner tube
- 053 Gasket for burner tube
- 054 Ignition electrode with gasket
- 055 Ionization electrode with gasket
- 058 Gasket for radial fan
- 059 Radial fan NRG118 with gaskets
- 061 Gas valve CES with gaskets
- 062 Burner mounting flange assembly with gaskets
- 063 Ignition transformer, BW12126-00
- 070 Electrode block gasket
- 071 Ignition electrode gasket
- 072 Gasket set for gas connection pipe
- 073 Fixed orifice, NG + LPG
- 074 Venturi extension with gasket

Other Parts (not illustrated)

- 202 Touch-up spray paint "Vitowhite"
- 203 Touch-up paint stick "Vitowhite"

(A) CSA Rating Plate

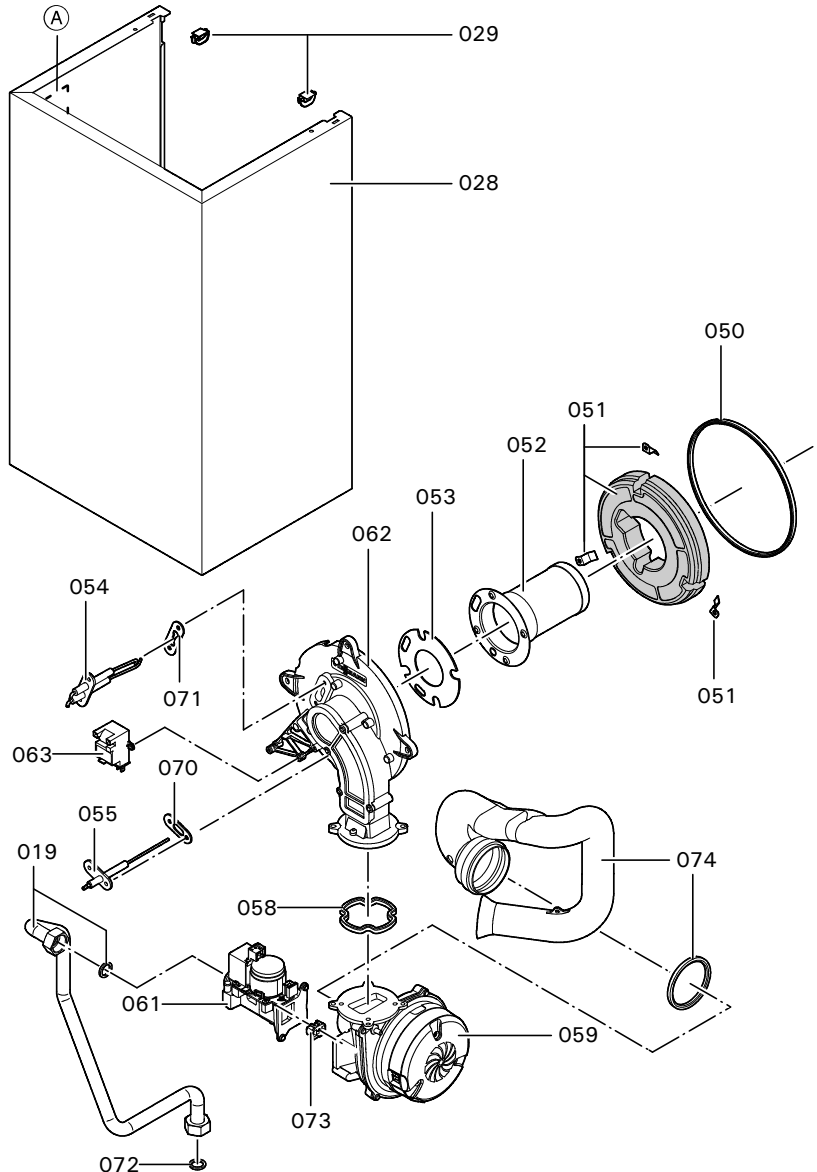

Parts Lists *(continued)*

Parts

- 001 Air vent w shut-off base, 3/8"
- 002 Heating supply connection pipe for heat exchanger
- 003 Heating supply connection pipe extension
- 004 Heating return connection pipe for heat exchanger
- 005 Heating return connection pipe extension
- 006 Heat exchanger assembly, ASME
- 007 Flue gas gasket
- 009 Condensate pipe
- 010 Condensate hose
- 011 Condensate hose
- 012 Test port cap (set of 2)
- 013 Vent pipe adaptor 60/100
- 014 Air intake cover
- 015 Air intake gasket, DN60
- 016 Air intake cap
- 017 Sealing grommet, DN60
- 018 Combustion chamber refractory
- 020 Fastener set for return pipe
- 021 Clip d = 8 (set of 5)
- 022 Connector retaining clip (set of 2)
- 023 Sealing grommet set
- 024 O-Ring set for heat exchanger, 21x3mm
- 025 O-Ring set for supply/return, 18x3mm
- 026 Support bracket set for heat exchanger
- 027 Spring clip set
- 030 Wall-mount bracket assembly
- 151 Flue gas temperature sensor
- 152 Fixed high limit, 210°F / 99°C
- 153 Boiler temperature sensor
- 154 Flow switch, VK315M

- (B) ASME Rating Plate
- (C) Boiler Serial No.

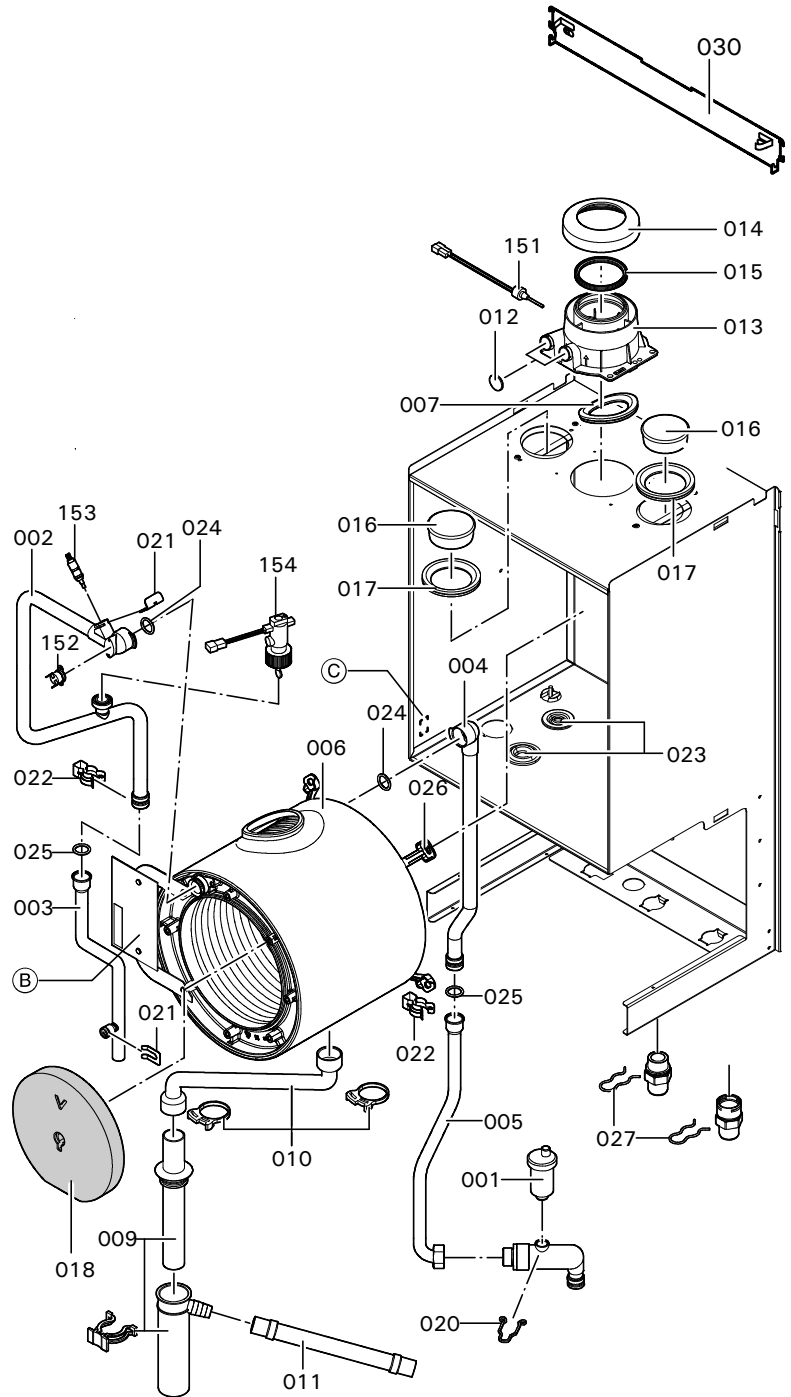

Additional Information

Parts Lists *(continued)*

Parts

- 008 Pressure gage, PSI
- 080 Control console
- 081 Back cover, control console
- 082 Fastening clip
(set of 10)
- 083 Control housing, bottom
- 084 Flip-down cover
- 085 Pressure gage insert
- 086 Clip for control housing,
(set of 10)
- 087 Hinges for control housing
(set of 10)
- 089 Fuse, 6.3A/250V
(set of 10)
- 091 Vitotronic 200 H01
- 093 LON communication module H01
with LON module adaptor
(Pos. 094)
- 094 Circuit board
(LON module adaptor)
- 095 Fuse holder
- 098 Coding plug for 0-5000ft.
- 099 Coding plug for 5000-10000ft.
- 150 Outdoor temperature sensor

Other Parts (not illustrated)

- 400 Installation fittings *1
- 410 Power/pump module *2
- 430 Technical Literature Set
- 431 LPG conversion labels
- 432 Installation Instructions
- 433 Service Instructions
- 434 Operating Instructions
and User's Information Manual
- 436 Installation Instructions
for Venting System
- 437 Warranty Sheet
- 438 Parts List, Installation Fittings

*1 See separate Parts List
for installation fittings.

*2 See separate Parts List
for power/pump module.

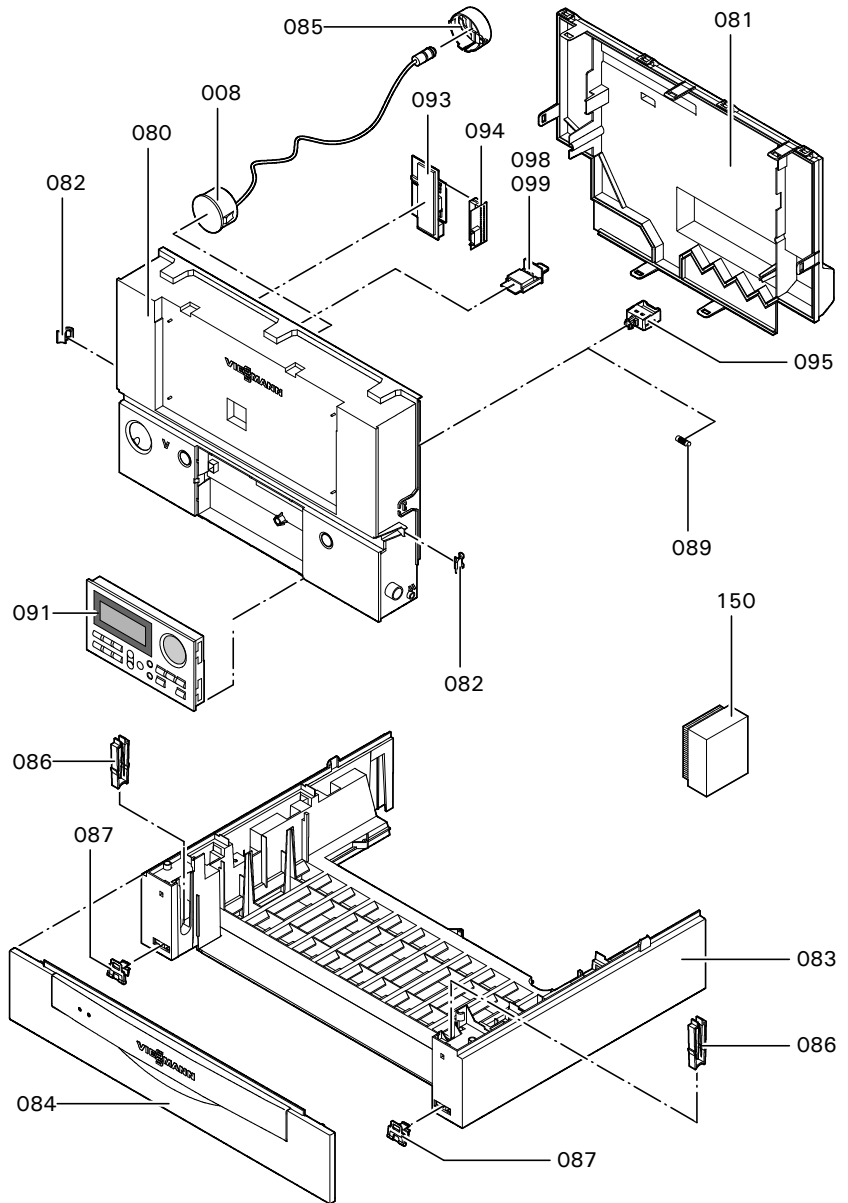

Measurements		Service date: by:	Service date: by:	Service date: by:	Service date: by:	Service date: by:	Service date: by:	Setpoint value
Static pressure	"w.c.							max. 14 "w.c.
Running pressure (supply pressure)								
<input type="checkbox"/> Natural gas	"w.c.							4-14 "w.c.
<input type="checkbox"/> LPG	"w.c.							11-14 "w.c.
<i>Check gas type</i>								
Carbon dioxide content CO₂								
<input checked="" type="checkbox"/> at lower end of rated input range	vol.-%							
<input checked="" type="checkbox"/> at upper end of rated input range	vol.-%							
Oxygen content O₂								
<input checked="" type="checkbox"/> at lower end of rated input range	vol.-%							
<input checked="" type="checkbox"/> at upper end of rated input range	vol.-%							
Carbon monoxide content CO								
<input checked="" type="checkbox"/> at lower end of rated input range	ppm							50 ppm air-free*
<input checked="" type="checkbox"/> at upper end of rated input range	ppm							
Ionization current	µA							min. 5 µA

*Fuel type, altitude, venting and other site parameters may change CO to higher or lower readings. Max. CO limit to ANSI standards requirement is 400 PPM.

Additional Information

Technical Data

Boiler Model	Model No. WB2B-	19	26	35
Natural gas / Liquid propane gas				
CSA input	MBH	31-67	31-93	31-125
	kW	9-20	9-27	9-37
CSA output/DOE ^{*1}	MBH	28-61	28-85	28-114
heating capacity	kW	8-18	8-25	8-33
Net I = B = R rating ^{*2}	MBH	53	74	99
Heat exchanger surface area	ft. ²	10.23	10.23	10.23
	m ²	0.95	0.95	0.95
Min. gas supply pressure				
Natural gas	"w.c.	4	4	4
Liquid propane gas	"w.c.	10	10	10
Max. gas supply pressure ^{*3}				
Natural gas	"w.c.	14	14	14
Liquid propane gas	"w.c.	14	14	14
A.F.U.E.	%	96.1	96.1	96.1
CSA thermal efficiency				
ANSI Z21.13/CSA 4.9	%			
Weight	lbs	102	102	102
	kg	46	46	46
Boiler water content	USG	0.87	0.87	0.87
	ltr	3.3	3.3	3.3
Boiler max. flow rate ^{*4}	GPM	6.2	6.2	6.2
	ltr/h	1400	1400	1400
Max. operating pressure	psig	45	45	45
at 210°F / 99°C	bar	3	3	3
Boiler water temperature				
– Adjustable high limit (AHL)				
range				
space heating	°F/		68 to 165 /	
(steady state)	°C		20 to 74	
DHW production	°F/		165 /	
	°C		74	
– Fixed high limit (FHL)				
	°F/°C		210/99	
Boiler connections				
Boiler heating supply and return	NPTM "	¾	¾	¾
Pressure relief valve	NPTF "	¾	¾	¾
Drain valve	(male	¾	¾	¾
	thread)			
Boiler supply/return for				
indirect-fired DHW storage tank	NPT"	¾	¾	¾
(field supplied)				
Gas valve connection, NPTF		¾	¾	¾

^{*1}Output based on 140°F / 60°C, 120°F / 49°C system supply/return temperature.

^{*2}Net I = B = R rating based on piping and pick-up allowance of 1.15.

^{*3}If the gas supply pressure exceeds the maximum gas supply pressure value, a separate gas pressure regulator must be installed upstream of the heating system.

^{*4}See section "Typical System Flow Rates" in the Vitodens 200-W, WB2B Installation Instructions.

Technical Data *(continued)*

Boiler Model	Model No. WB2B-	19	26	35
Dimensions				
Overall depth	inches	14	14	14
	mm	360	360	360
Overall width	inches	17¾	17¾	17¾
	mm	450	450	450
Overall height	inches	33½	33½	33½
	mm	850	850	850
Height with flue gas elbow (accessory)	inches	44	44	44
	mm	1 116	1 116	1 116
Flue gas^{*5}				
Temperature (at boiler return temperature of 86°F / 30°C)				
– at rated full load	°F/°C	113/45	113/45	113/45
– at rated partial load	°F/°C	95/35	95/35	95/35
Temperature (at boiler return temperature of 140°F / 60°C)				
	°F/°C	154/68	158/70	158/70
Average condensate flow rate^{*6}				
with natural gas and – T _S /T _R = 104/86°F / 40/30°C				
	USG/day	2.6-3.4	2.9-3.4	4-4.5
	ltr/day	10-12	11-13	15-17
Condensate connection^{*7}				
	hose nozzle Ø in			
		1	1	1
Boiler flue gas connection^{*8}				
	Ø			
	in/mm	2¾ / 60	2¾ / 60	2¾ / 60
Combustion air supply connection (coaxial)^{*8}				
	outer			
	Ø in/mm	4/100	4/100	4/100

^{*5} Measured flue gas temperature with a combustion air temperature of 68°F / 20°C.

^{*6} Based on typical boiler cycles, including partial load conditions.

^{*7} Requires 1" / 25 mm tubing. See Vitodens 200-W, WB2B Installation Instructions for details.

^{*8} **For side wall vent installations (coaxial system):**

Do **not** exceed max. equivalent length specified in the Installation Instructions of the Vitodens 200-W, WB2B Venting System.

A **maximum of five elbows** may be installed in the vent system.

Do **not** attempt to common-vent Vitodens 200-W, WB2B with any other appliance.

Venting material to be supplied by Viessmann **only**; side wall vent installation **must** include Viessmann protective screen!

For details refer to the Installation Instructions for the Vitodens 200-W, WB2B Venting System.

► For information regarding other Viessmann System Technology componentry, please reference documentation of respective product.

Lighting and Operating Instructions

FOR YOUR SAFETY READ BEFORE OPERATING

W A R N I N G: If you do not follow these instructions exactly, a fire or explosion may result causing property damage, personal injury or loss of life.

- A. This appliance does not have a pilot. It is equipped with an ignition device which automatically lights the burner. Do not try to light the burner by hand.
- B. **BEFORE OPERATING** smell all around the appliance area for gas. Be sure to smell next to the floor because some gas is heavier than air and will settle on the floor.
- WHAT TO DO IF YOU SMELL GAS**
- Do not try to light any appliance.
 - Do not touch any electric switch; do not use any phone in your building.
 - Immediately call your gas supplier from a neighbor's phone. Follow the gas supplier's instructions.
 - If you cannot reach your gas supplier, call the fire department.
- C. Use only your hand to push in or turn the gas control knob. Never use tools. If the knob will not push in or turn by hand, don't try to repair it, call a qualified service technician. Force or attempted repair may result in a fire or explosion.
- D. Do not use this appliance if any part has been under water. Immediately call a qualified service technician to inspect the appliance and to replace any part of the control system and any gas control which has been under water.

OPERATING INSTRUCTIONS

1. **STOP!** Read the safety information above on this label.
2. Set thermostat or other operating control to lowest setting.
3. Turn off all electric power to the appliance.
4. This device is equipped with an ignition device which automatically lights the burner. Do not try to light the burner by hand.
5. Close main gas shutoff valve.
6. Wait five (5) minutes to clear out any gas. Then smell for gas, including near the floor. If you smell gas, **STOP!** Follow "B" in the safety information above on this label. If you don't smell gas, go to the next step.
7. Open main gas shutoff valve.
8. Turn on all electric power to the appliance.
9. Set thermostat or other operating control to desired setting.
10. If the appliance will not operate, follow the instructions "To Turn Off Gas To Appliance" and call your service technician or gas supplier.

Manual gas shutoff

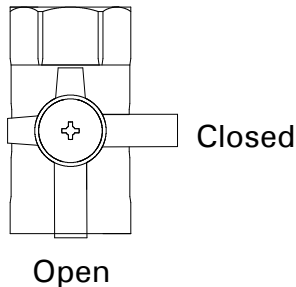

TO TURN OFF GAS TO BOILER

1. Set thermostat or other operating control to lowest setting.
2. Turn off all electric power to the appliance if service is to be performed.
3. Close main gas shutoff valve.









Viessmann Manufacturing Company Inc.
750 McMurray Road
Waterloo, Ontario • N2V 2G5 • Canada
Technifo Line 1-888-484-8643
1-800-387-7373 • Fax (519) 885-0887
www.viessmann.ca • info@viessmann.ca

Viessmann Manufacturing Company (U.S.) Inc.
45 Access Road
Warwick, Rhode Island • 02886 • USA
Technifo Line 1-888-484-8643
1-800-288-0667 • Fax (401) 732-0590
www.viessmann-us.com • info@viessmann-us.com

