

# Installation Instructions

for use by heating contractor

# VIESSMANN®

Vitodens 200-W, WB2B Series

Models 45, 60

Wall-mounted, gas-fired condensing boiler

For operation with natural gas and liquid propane gas

Heating input 60 to 212 MBH

17 to 62 kW

Please file in Service Binder



## VITODENS 200-W®

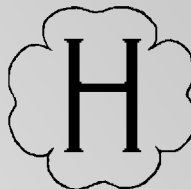

**IMPORTANT**

**Read and save these instructions for future reference.**

## Safety, Installation and Warranty Requirements

Please ensure that these instructions are read and understood before commencing installation. Failure to comply with the instructions listed below and details printed in this manual can cause **product/property damage, severe personal injury, and/or loss of life**. Ensure all requirements below are understood and fulfilled (including detailed information found in manual subsections).

### ■ Licensed professional heating contractor

The installation, service, and maintenance of this equipment *must be performed* by a licensed professional heating contractor.

► Please see section entitled "Important Regulatory and Installation Requirements" in the Installation Instructions.



### ■ Carbon monoxide

Improper installation, service and/or maintenance can cause flue products to flow into living space. Flue products contain *poisonous* carbon monoxide gas.

► For information pertaining to the proper installation, service and maintenance of this equipment to avoid formation of carbon monoxide, please see the Installation Instructions of the Vitodens 200-W Venting System.



### ■ Equipment venting

Never operate boiler without an *installed venting system*. An improper venting system can cause carbon monoxide poisoning.

### ■ Warranty

Information contained in this and related product documentation must be read and followed. *Failure to do so renders warranty null and void.*



### ■ Product documentation

Read all applicable documentation before commencing installation. Store documentation near boiler in a readily accessible location for reference in the future by service personnel.

► For a listing of applicable literature, please see section entitled "Important Regulatory and Installation Requirements" in the Installation Instructions.



 **WARNING**

**Installers must follow local regulations with respect to installation of carbon monoxide detectors. Follow manufacturer's maintenance schedule of boiler.**

### ■ Advice to owner

Once the installation work is complete, the heating contractor must familiarize the system operator/ultimate owner with all equipment, as well as safety precautions/requirements, shut-down procedure, and the need for professional service annually before the heating season begins.

**General Information**

**Important Regulatory and Installation Requirements** ..... 5

**About these Installation Instructions** ..... 7

**Applicability** ..... 8

**Product Information** ..... 8

**Mechanical Room** ..... 9

**Set-up**

**Before Set-up** ..... 10

**Minimum Clearances** ..... 10

**Boiler Connections**

**Preparing the Connections** ..... 11

Connections overview ..... 11

**Wall Mounting** ..... 13

Installing the wall mounting bracket ..... 13

Mounting the boiler ..... 15

**Connections** ..... 16

Connecting the power supply ..... 16

Boiler venting ..... 16

Proper piping practice ..... 16

Gas shut-off valve connection ..... 16

Gas connection and piping ..... 17

Gas piping pressure test ..... 18

Heating water connections ..... 19

DHW storage tank information ..... 20

Making the DHW connections ..... 20

Accessing the control unit cables ..... 22

Connecting DHW sensor ..... 23

High altitudes setting ..... 23

Condensate connection ..... 24

**Safety Connections and Pressure Testing** ..... 25

Installing boiler safety devices ..... 25

Performing boiler pressure test ..... 26

**Installation Examples** ..... 27

Waterside flow (primary circuit) ..... 28

System layout 1 ..... 29

System layout 2 ..... 30

System layout 3 ..... 31

System layout 4 ..... 32

System layout 5 ..... 33

System layout 6 ..... 34

System layout 7 ..... 35

System layout 8 ..... 36

System layout 9 ..... 37

Vitodens 200-W, WB2B (alternate DHW connection) ..... 38

Boiler in heating/cooling application ..... 39

Boiler with low water cut-off (remote-mounted, field supplied) ..... 40

**Venting Connection** ..... 40

## Control Connections

<b>Electrical Connections</b> .....	41
Overview of electrical connections and plug-in connectors .....	41
Connecting the Power/Pump module .....	41
Power/Pump module electrical connectors .....	43
Boiler control board GC 130 electrical connectors .....	44
Connection between the Power/Pump module and boiler .....	45
Accessories electrical connections .....	46
Accessing the X3 plug .....	47
Connecting the low-loss header sensor .....	47
Connecting the outdoor temperature sensor .....	48
External switching of heating program/External heat demand/ External blocking .....	49
External 0-10 volt signal connection .....	49
Connecting the LON communication module .....	50
Accessory kit connections for heating circuit with mixing valve part no. 7133392 (old version) .....	52
Accessory kit connections for heating circuit with mixing valve part no. 7837524 (new version) .....	53
Wiring diagram for the boiler / Power/Pump module .....	54
<b>Installing the Programming Unit of the Control Unit</b> .....	55
Closing the control unit and inserting the programming unit .....	55
Reinstalling the front enclosure panel .....	55

## Additional Information

<b>Technical Data</b> .....	56
<b>Wiring Diagram</b> .....	58
Complete system wiring diagram .....	58
<b>Lighting and Operating Instructions</b> .....	60
<b>Ladder Diagram</b> .....	61

## Important Regulatory and Installation Requirements

### Codes

The installation of this unit shall be in accordance with local codes or, in the absence of local codes, use CAN/CSA-B149.1 or .2 Installation Codes for Gas Burning Appliances for Canada. For U.S. installations use the National Fuel Gas Code ANSI Z223.1. Always use latest editions of codes.

In Canada all electrical wiring is to be done in accordance with the latest edition of CSA C22.1 Part 1 and/or local codes. In the U.S. use the National Electrical Code ANSI/NFPA 70. The heating contractor must also comply with both the Standard for Controls and Safety Devices for Automatically Fired Boilers, ANSI/ASME CSD-1, and the Installation Code for Hydronic Heating Systems, CSA B214-01, where required by the authority having jurisdiction.

### Instructing the system user

The installer of the system is responsible to ensure the system operator/ultimate owner is made familiar with the system functioning, its activation, and its shut-down.

### Initial start-up

Initial start-up must be performed by a qualified heating contractor. Proper completion of the Maintenance Record by the heating contractor is also required.

### Working on the equipment

The installation, adjustment, service, and maintenance of this boiler must be done by a **licensed professional heating contractor** who is qualified and experienced in the installation, service, and maintenance of hot water boilers. **There are no user serviceable parts on the boiler, burners, or control.**

Ensure **main power** supply to equipment, the heating system, and all external controls has been **deactivated**. **Close main gas supply valve**. Take precautions in all instances to avoid accidental activation of power during service work.

### Technical literature

Literature for the Vitodens boiler:

- Technical Data Manual
- Installation Instructions
- Start-up/Service Instructions
- Operating Instructions and User's Information Manual
- Instructions of other Viessmann products utilized and installed
- Installation codes mentioned in this manual

→ *The following topics must be covered:*  
*Proper system operation sequence.*  
*Explain the equipment.*  
*Demonstrate an emergency shut-down, what to do and what not.*  
*Explain that there is no substitute for proper maintenance to help ensure safe operation.*

→ *The Maintenance Record is located in the Start-up and Service Instructions.*

→ *Please carefully read this manual prior to attempting start-up, maintenance or service. Any warranty is null and void if these instructions are not followed.*

*For information regarding other Viessmann System Technology componentry, please reference documentation of the respective product.*

*We offer frequent installation and service seminars to familiarize our partners with our products. Please inquire.*

→ *The completeness and functionality of field supplied electrical controls and components must be verified by the heating contractor. These include low water cut-offs, flow switches (if used), staging controls, pumps, motorized valves, air vents, thermostats, etc.*

→ *Leave all literature at the installation site and advise the system operator/ultimate owner where the literature can be found. Contact Viessmann for additional copies.*

→ *This product comes with several safety instruction labels attached. Do not remove!*  
*Contact Viessmann immediately if replacement labels are required.*

### Important Regulatory and Installation Requirements *(continued)*

For installations on the Commonwealth of Massachusetts, the following modifications to NFPA-54 chapter 10 apply:

Excerpt from 248 CMR 5-08:

- 2(a) For all side-wall horizontally vented gas fueled equipment installed in every dwelling, building or structure used in whole or in part for residential purposes, including those owned or operated by the Commonwealth and where the side-wall exhaust vent termination is less than (7) feet above finished grade in the area of the venting, including but not limited to decks and porches, the following requirements shall be satisfied:
1. **INSTALLATION OF CARBON MONOXIDE DETECTORS.** At the time of installation of the side-wall horizontal vented gas fueled equipment, the installing plumber or gasfitter shall observe that a hard wired carbon monoxide detector with an alarm and battery back-up is installed on the floor level where the gas equipment is to be installed. In addition, the installing plumber or gasfitter shall observe that a battery operated or hard wired carbon monoxide detector with an alarm is installed on each additional level of the dwelling, building or structure served by the side-wall horizontal vented gas fueled equipment. It shall be the responsibility of the property owner to secure the services of qualified licensed professional for the installation of hard-wired carbon monoxide detectors.
    - a. In the event that the side-wall horizontally vented gas fueled equipment is installed in a crawl space or an attic, the hard-wired carbon monoxide detector with alarm and battery back-up may be installed on the next adjacent floor level.
    - b. In the event that the requirements of this subdivision can not be met at the time of completion of installation, the owner shall have a period of thirty (30) days to comply with the above requirements; provided, however, that during said thirty (30) day period, a battery operated carbon monoxide detector with an alarm shall be installed.
  2. **APPROVED CARBON MONOXIDE DETECTORS.** Each carbon monoxide detector as required in accordance with the above provisions shall comply with NFPA 720 and be ANSI/UL 2034 listed and IAS certified.
  3. **SIGNAGE.** A metal or plastic identification plate shall be permanently mounted to the exterior of the building at a minimum height of eight (8) feet above grade directly in line with the exhaust vent terminal for the horizontally vented gas fueled heating appliance or equipment. The sign shall read, in print size no less than one-half (1/2) inch in size, "GAS VENT DIRECTLY BELOW. KEEP CLEAR OF ALL OBSTRUCTIONS".
  4. **INSPECTION.** The state or local gas inspector of the side-wall horizontally vented gas fueled equipment shall not approve the installation unless, upon inspection, the inspector observes carbon monoxide detectors and signage installed in accordance with the provisions of 248 CMR 5.08(2)(a) 1 through 4.
- (b) **EXEMPTIONS:** The following equipment is exempt from 248 CMR 5.08(2)(a) 1 through 4:
1. The equipment listed in Chapter 10 entitled "Equipment Not Required To Be Vented" in the most current edition of NFPA 54 as adopted by the Board; and
  2. Product Approved side-wall horizontally vented gas fueled equipment installed in a room or structure separate from the dwelling, building or structure used in whole or in part for residential purposes.

## About these Installation Instructions

 Take note of all symbols and notations intended to draw attention to potential hazards or important product information. These include "WARNING", "CAUTION", and "IMPORTANT". See below.

 <b>WARNING</b>
Indicates an imminently hazardous situation which, if not avoided, could result in death, serious injury or substantial product/property damage.

→ *Warnings draw your attention to the presence of potential hazards or important product information.*

 <b>CAUTION</b>
Indicates an imminently hazardous situation which, if not avoided, may result in minor injury or product/property damage.

→ *Cautions draw your attention to the presence of potential hazards or important product information.*

<b>IMPORTANT</b>
------------------

→ *Helpful hints for installation, operation or maintenance which pertain to the product.*

→

→ *This symbol indicates that additional, pertinent information is to be found in column three.*



→ *This symbol indicates that other instructions must be referenced.*

## Applicability

**CAUTION**  
The boiler serial number must be provided when ordering replacement parts. Some replacement parts are not reverse compatible with previous versions of the Vitodens 200-W WB2B boiler.

### IMPORTANT

When ordering replacement parts, provide either the 16-digit boiler serial number (on the bar code label) or the 12-digit ASME/NB serial number, located as shown underneath boiler front enclosure panel. Refer to page 15 for instructions on how to remove front enclosure panel.

Model No. WB2B 45  
Serial No. 7374866 □□□□□□□□

Model No. WB2B 60  
Serial No. 7374867 □□□□□□□□

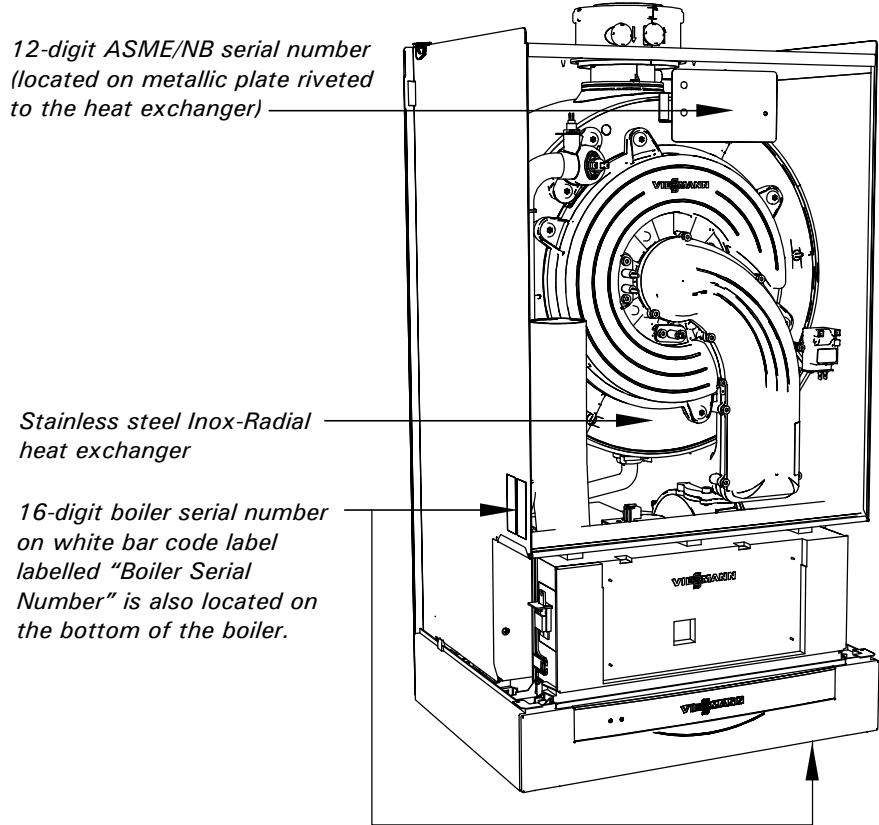

Fig. 1 Locating boiler serial numbers for ordering replacement parts

## Product Information

Natural gas and liquid propane gas-fired wall-mounted condensing heating boiler for weather-responsive operation in closed loop, forced circulation hot water heating systems for space heating and domestic hot water (DHW) production.

The Vitodens 200-W, WB2B series boiler comes factory set for operation with natural gas. For a fuel conversion to liquid propane gas no conversion kit is required.

Boiler model must be selected based on an accurate heat loss calculation of the building. Ensure boiler model is compatible with connected radiation.

Vitodens 200-W, WB2B series boilers are factory-tested and calibrated. Further gas valve adjustments are not typically required during field start-up.



See the Vitodens 200-W, WB2B Start-up/Service Instructions.



## Mechanical Room

During the early stages of designing a new home, we recommend that proper consideration be given to constructing a separate mechanical room dedicated to the gas- or oil-fired heating equipment and domestic hot water storage tank(s).

The boiler must be located in a heated indoor area, near a floor drain, and as close as possible to a wall. Whenever possible, install the boiler near an outside wall so that it is easy to duct the venting system to the boiler.

Locate the boiler on a wall capable of supporting the weight of the boiler filled with water (see section entitled "Technical Data" on page 55 for information required for total boiler weight calculation). Ensure that the boiler location does not interfere with the proper circulation of combustion and ventilation air of other fuel burning equipment within the mechanical room (if applicable).

The maximum room temperature of the mechanical room where the boiler is located must not exceed 104°F / 40°C.

### Installation area conditions

 **WARNING**

**Incorrect ambient conditions can lead to damage to the heating system and put safe operation at risk.**

- Ensure ambient temperatures are higher than 32°F / 0°C and lower than 104°F / 40°C.
- Prevent the air from becoming contaminated by halogenated hydrocarbons (e.g. as contained in paint solvents or cleaning fluids) and excessive dust (e.g. through grinding or polishing work). Combustion air for the heating process, and ventilation of the boiler room must be free of corrosive contaminants. To that end, any boiler must be installed in an area that has no chemical exposure. The list to the right indicates the main, currently known sources.
- Avoid continuously high levels of humidity (e.g. through frequent drying of laundry).
- Never close existing ventilation openings.

 **WARNING**

**If you notice fire coming from the appliance, call the fire department immediately! Do not attempt to extinguish the fire unless qualified to do so.**

 **WARNING**

**Fire causes a risk of burns and explosion!**

- Shut down the boiler
- Close fuel shut-off valves
- Use a tested fire extinguisher, class ABC.

### Sources of combustion and ventilation air contaminants

#### *Areas likely to contain contaminants:*

- New building construction
- Swimming pools
- Remodelling areas, hobby rooms
- Garages with workshops
- Furniture refinishing areas
- Dry cleaning/laundry areas and establishments
- Auto body shops
- Refrigeration repair shops
- Metal fabrication plants
- Plastic manufacturing plants
- Photo processing plants
- Beauty salons

#### *Products containing contaminants:*

- Chlorine-type bleaches, detergents and cleaning solvents found in household laundry rooms
- Paint and varnish removers
- Hydrochloric acid, muriatic acid
- Chlorine-based swimming pool chemicals
- Spray cans containing chlorofluorocarbons
- Chlorinated waxes and cleaners
- Cements and glues
- Refrigerant leaks
- Calcium chloride used for thawing
- Sodium chloride used for water softening salt
- Permanent wave solutions
- Adhesives used to fasten building products and other similar items
- Antistatic fabric softeners used in clothes dryers

### Boiler operation in marine environments (damp, salty coastal areas)

**IMPORTANT**

The service life of the boiler's exposed metallic surfaces, such as the casing and fan housing, is directly influenced by proximity to damp and salty marine environments. In such areas, higher concentration levels of chlorides from sea spray, coupled with relative humidity, can lead to degradation of the exposed metallic surfaces mentioned above. Therefore, it is imperative that boilers installed in such environments **not** be installed using direct vent systems which draw outdoor air for combustion. Such boilers must be installed using room air dependent vent systems; i.e. using room air for combustion. The indoor air will have a much lower relative humidity and, hence, potential corrosion will be minimized.

## Before Set-up

Before placing boiler in its installation location, ensure all necessary accessories are installed.

**⚠ CAUTION**

The boiler must be installed in such a way that gas ignition system components are protected from water (spraying, splashing, etc.) during boiler operation and service.

## Minimum Clearances

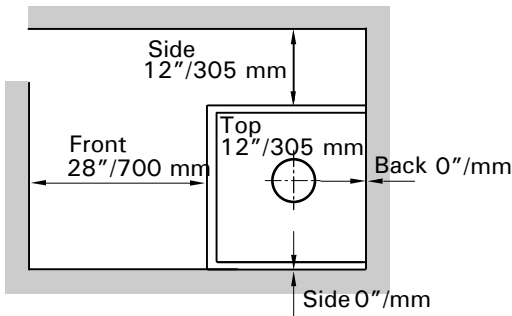

Fig. 2 Recommended min. service clearances

**Note:**  
The Vitodens 200-W, WB2B boiler has passed the zero inches vent clearance to combustibles testing requirements dictated by the boiler Harmonized Standard ANSI Z21.13, CSA 4.9.2007 and therefore is listed for zero clearance to combustibles when vented with a single-wall special venting system (AL-29-4C material) or UL/ULC-listed CPVC gas vent material. The zero inches vent clearance to combustibles for the Vitodens 200-W, WB2B boiler supercedes the clearance to combustibles listing that appears on the special venting system label.

### Recommended minimum service clearances

For typical Vitodens installations, Viessmann recommends installing the boiler with the clearances shown in the illustration on the left.

**Note:**  
The 12" (305 mm) side clearance specified is only recommended to be able to view the boiler certified rating plate, decal and also accommodate the PRV installation kit.

If the pressure relief valve is rotated 90° facing forward by using an extension between the tee and the boiler connection, then this clearance can be reduced to 1/2". This 1/2" clearance is only required to be able to remove the boiler's front cover and view the rating plate attached to it, if needed. This reduced clearance is also used in Vitodens multiple boiler installation system as described in the multiple boiler installation instructions.

The Vitodens 200-W, WB2B boiler is approved for closet and alcove installation with the following clearances to combustibles.

**Table 1. Clearances**

Top	Front	Rear	Left	Right	Vent pipe
0	0 AL, CL	0	0	0	0

AL = Alcove  
CL = Closet



See the Vitodens 200-W WB2B Venting System Installation Instructions for details.

# Preparing the Connections

## Connections overview

Use an approved pipe sealant or teflon tape when connecting the following installation fittings.

This section constitutes an overview only! Refer to subsequent sections for detailed information on individual piping connections.

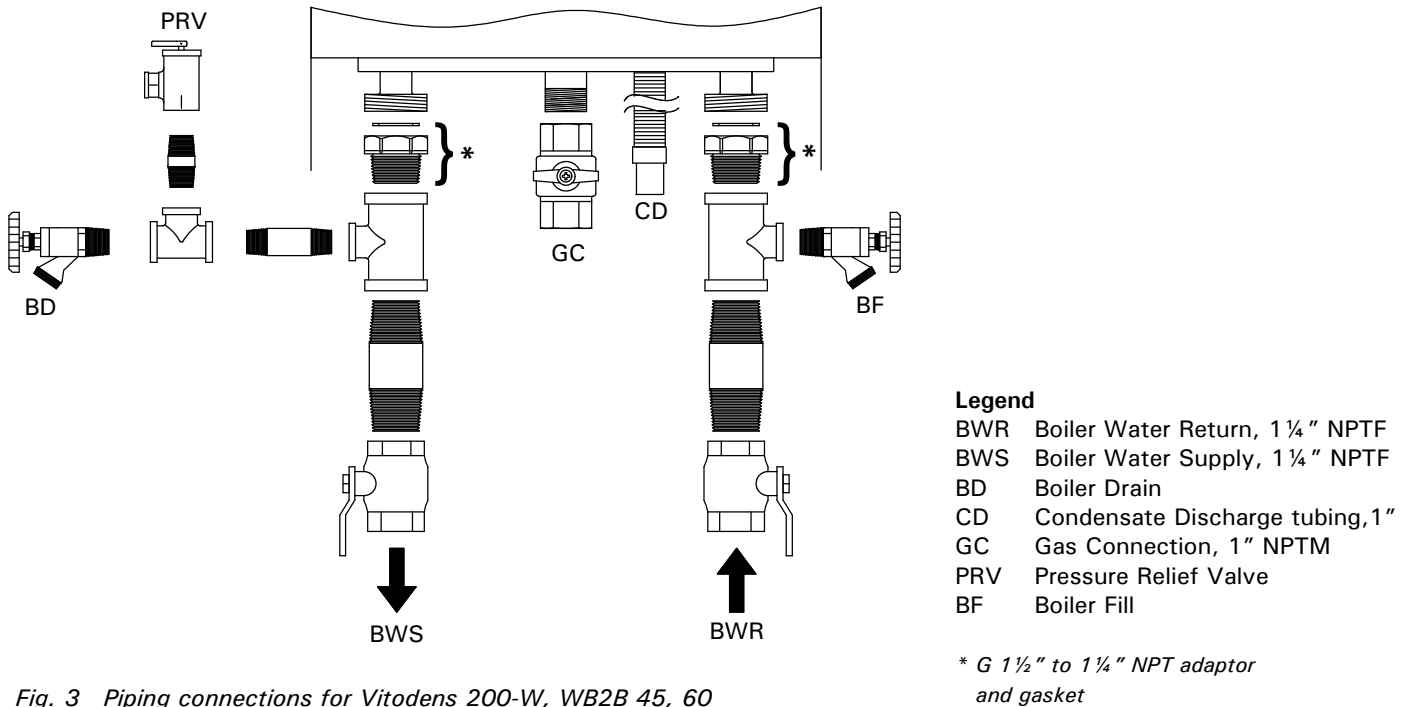



Fig. 3 Piping connections for Vitodens 200-W, WB2B 45, 60

**Preparing the Connections** *(continued)*

**Connections overview** *(continued)*

Use an approved pipe sealant or teflon tape when connecting the following installation fittings.

This section constitutes an overview only! Refer to subsequent sections for detailed information on individual piping connections.

 When preparing gas, water and electrical connections in the field, see section entitled "Wall Mounting" on page 13 of this manual for information regarding the installation of the wall mounting bracket.

**IMPORTANT**

The maximum ambient temperature must not exceed 104°F / 40°C.

1. Heating water connections and gas connection to be made in the field. See illustration to the left and connection-specific section for details.
2. See subsection entitled "Power supply connection" for details regarding power supply to the Vitodens 200-W WB2B boiler.

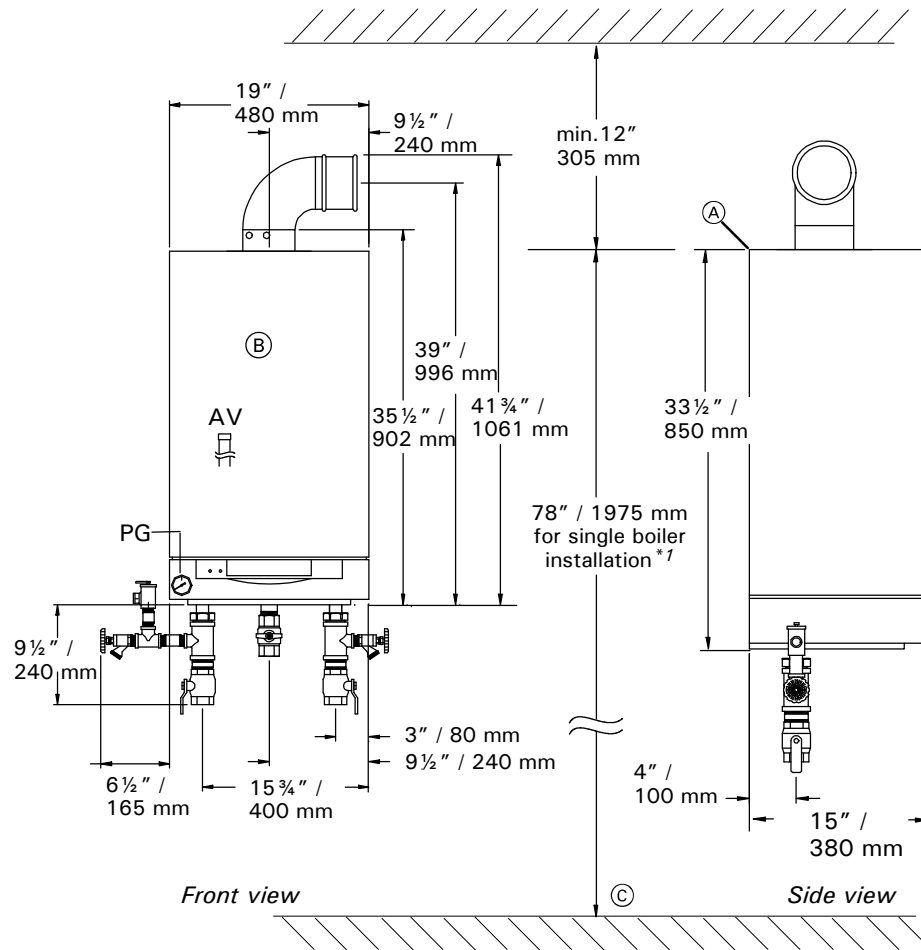

Fig. 4 Piping connections for Vitodens 200-W, WB2B 45, 60

- Legend**
- AV Air Vent (inside the boiler)
  - PG Pressure Gauge
  - Ⓐ Reference point for top of boiler
  - Ⓑ Vitodens 200-W boiler
  - Ⓒ Finished floor level

\*1 Recommendation

## Wall Mounting

### Installing the wall mounting bracket

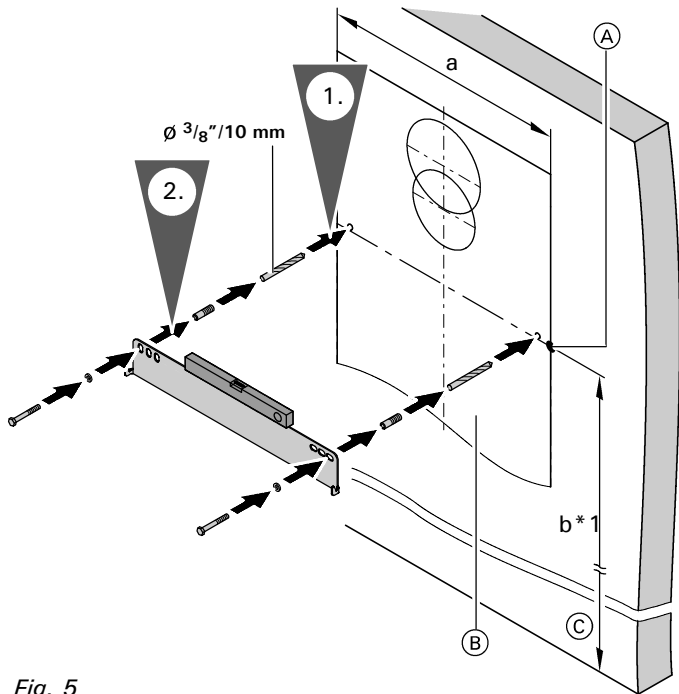

Fig. 5

#### Legend

- Ⓐ Reference point for top of boiler
- Ⓑ Mounting template
- Ⓒ Finished floor level

#### Dimensions

- a 19" / 483 mm
- b 78" / 1975 mm

\*1 Recommendation

The Vitodens 200-W WB2B can be wall-mounted on

- a brick/concrete wall
- wood studs
- metal studs

Following are the installation instructions for the mounting bracket on each material. Skip to the installation instructions applicable to your installation requirements.

#### **CAUTION**

Whichever mounting method is used, ensure that the bracket is tightly and securely fastened to wall. Failure to secure boiler properly could cause boiler to loosen, posing a severe safety hazard.

#### Installation of mounting bracket on brick/concrete wall:

1. Drill holes ( $\varnothing 3/8'' / 10 \text{ mm}$ ), using mounting template supplied with the boiler.
2. Align wall mounting bracket and attach to wall with the screws and bolts supplied.

**Wall Mounting** *(continued)*

**Installing the wall mounting bracket** *(continued)*

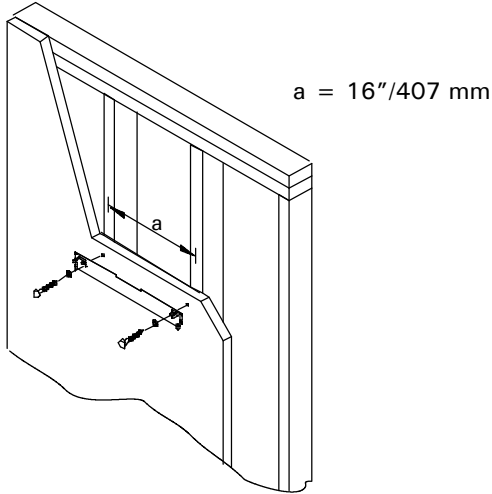

Fig. 6 General installation of mounting bracket

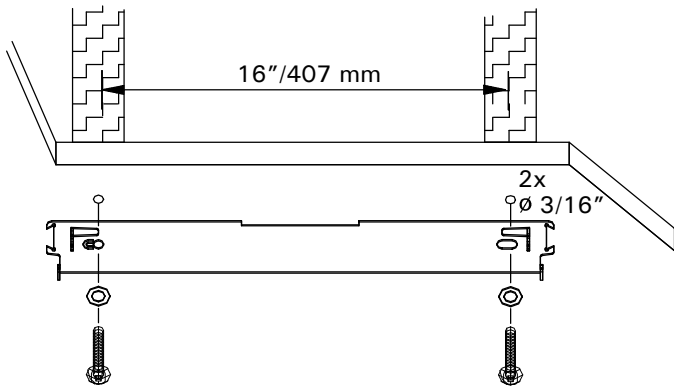

Fig. 7 Installation of mounting bracket on wood studs

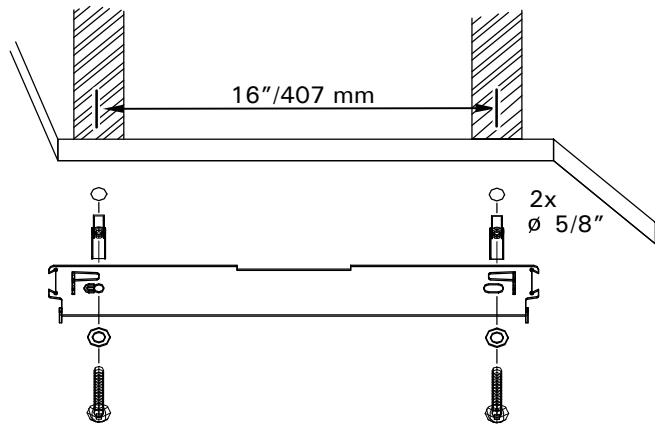

Fig. 8 Installation of mounting bracket on metal studs

**Installation of mounting bracket on wood and metal studs**

To mount the Vitodens 200-W WB2B boiler on wood or metal studs, install mounting bracket on wall as shown in Fig. 6.

Install mounting bracket on wood studs as per Fig. 7.  
 Drill  $\frac{3}{16}$ " pilot holes to insert mounting bolts.  
 Ensure that holes are located in the center of each wood stud.

Install mounting bracket on metal studs as per Fig. 8.  
 Drill  $\frac{5}{8}$ " pilot holes to insert mounting bolts.  
 Ensure that holes are located in the center of each metal stud.  
 Secure mounting bracket with bolts to metal studs as shown below.

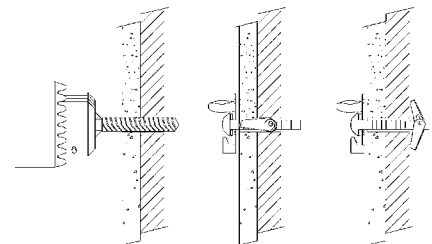

## Wall Mounting *(continued)*

### Mounting the boiler

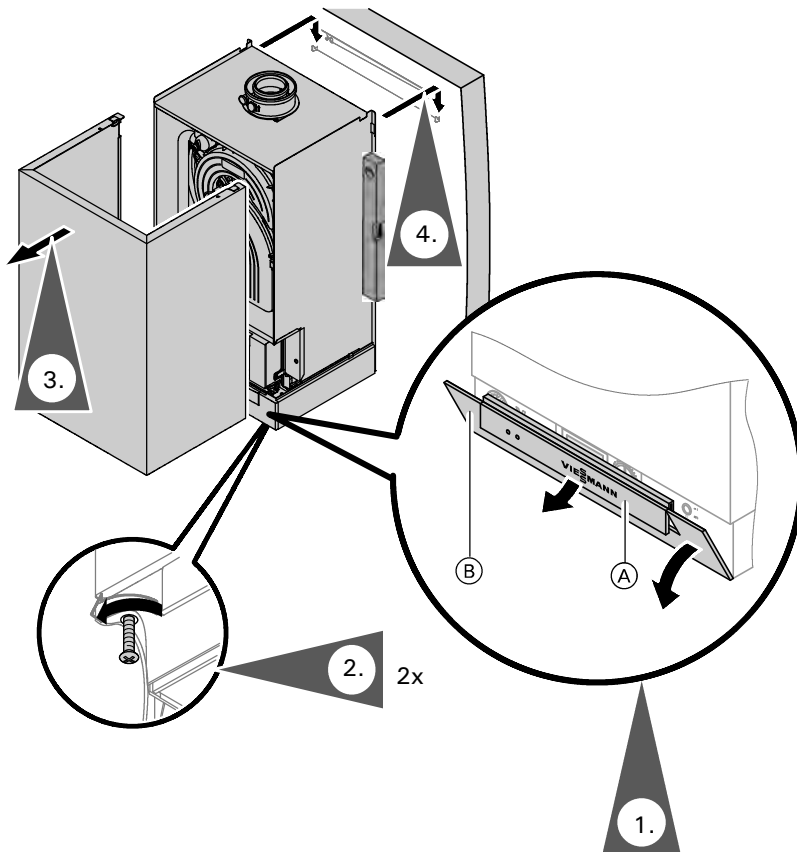

Fig. 9

1. To open hinged cover, lift cover (A) and pivot control unit flap (B) down. All boiler controls are located behind the control unit flap.
2. Loosen the screws at the bottom of the boiler; do not remove completely.
3. Remove front enclosure panel (lift up and pull towards you).



*For installation of the mounting bracket, see "Wall mounting" on page 13 of this manual.*

4. Mount boiler onto the mounting bracket and connect boiler to the installation fittings.

# Connections

## Connecting the power supply



See *Power/Pump Module Installation Instructions*

The Vitodens 200-W boiler is shipped with a Power/Pump module, which requires a 120 VAC power supply from a wall receptacle. The module contains a 120/230 VAC step-up transformer for 230 VAC operation.

Refer to the Installation Instructions shipped with the module or those contained in this manual for wiring details (see page 53).

## Boiler venting

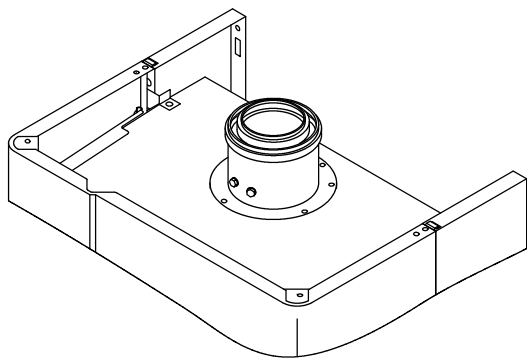

The Vitodens 200-W WB2B boiler comes with a pre-installed vent pipe adaptor (as shown in fig. 10). Run venting system, single-wall or coaxial, through the side wall or the roof, taking the shortest possible route and at a rising angle (min. 3°).



See *Installation Instructions WB2B Venting System for details.*

Fig. 10

## Proper piping practice

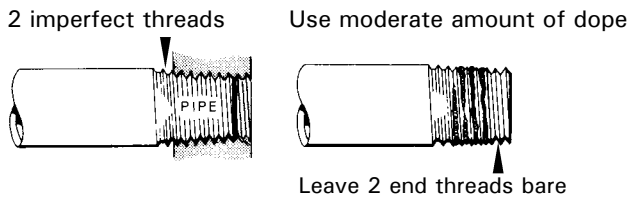

Support piping by proper suspension method. Piping must not rest on or be supported by boiler.

Fig. 11 Pipe threads

## Gas shut-off valve connection

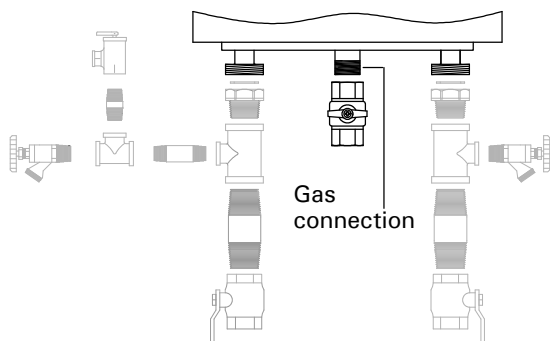

1. Make gas connections in accordance with codes CAN/CSA B149.1 and .2 or National Fuel Gas Code ANSI Z223.1/NFPA 54, as well as local codes.

2. Connect gas shutoff valve to the boiler gas connection.

3. Once connected close gas shutoff valve on boiler.

Fig. 12 Gas valve connection

See following page for details on gas connection and piping.



**Connections** *(continued)*

**Gas connection and piping**

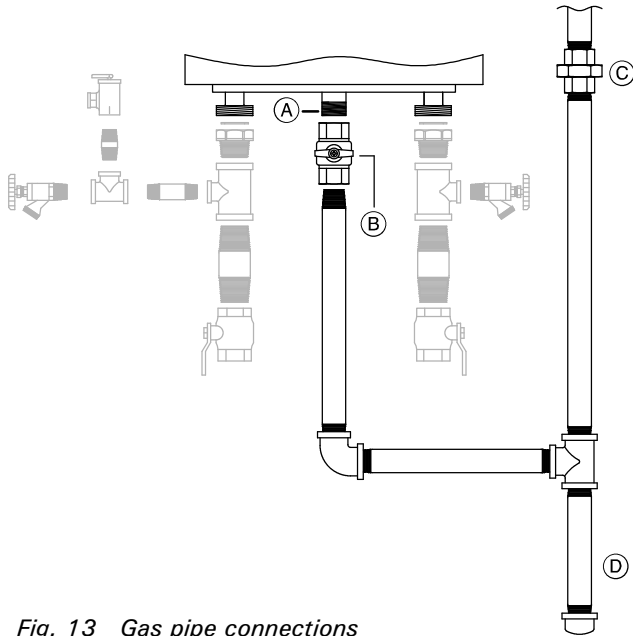

Fig. 13 Gas pipe connections

**Legend**

- (A) Gas connection  $\varnothing$  1" (NPT)
- (B) Accessible manual gas shutoff valve
- (C) Ground joint union
- (D) Drip leg

**! WARNING**  
 The gas supply piping must be leak tested before placing the boiler in operation.

**! CAUTION**  
 Ensure that gas piping is large enough for all appliances in the residence. No noticeable gas pressure drop in the gas line must occur when any unit (or combination of units) lights or runs.

1. Refer to current CAN/CSA B149.1 and .2 or National Fuel Gas Code ANSI Z223.1/NFPA 54, as well as local codes for gas piping requirements and sizing. Pipe size to the boiler must be determined based on:
  - pipe length
  - number of fittings
  - type of gas
  - maximum input requirements of all gas appliances in the residence.

**IMPORTANT**

**Design piping layout in such a way that piping does not interfere with serviceable components.**

2. Before connecting boiler to gas line, install ground joint union, capped drip leg and a manual equipment shutoff valve as shown. Valves must be listed by a nationally recognized testing agency. Make boiler gas connection as shown in Fig. 13.
3. Perform gas piping pressure test as described in the following subsection.

**IMPORTANT**

**Max. gas supply pressure: 14 "w.c.**

4. Identify shutoff valves as such with a tab and familiarize operator / ultimate owner of boiler with these valves.



See Vitodens 200-W WB2B Start-up/Service Instructions for applicable system coding information.

## Connections *(continued)*

### Gas piping pressure test

When performing the gas piping pressure test, ensure the following requirements are met.



#### WARNING

Never check for gas leaks with an open flame.



#### WARNING

Exposing boiler gas pressure regulator and gas valve to extreme pressures renders warranty null and void.

#### IMPORTANT

$\frac{1}{2}$  psig = 14 "w.c.

1. Isolate the boiler from the gas supply piping system using the individual manual shutoff valve during pressure tests equal to or less than  $\frac{1}{2}$  psig / 14 "w.c.
2. The boiler and its individual shutoff valve must be disconnected from the gas supply piping system during any pressure testing of that system at test pressures in excess of  $\frac{1}{2}$  psig / 14 "w.c.
3. Perform leak test.  
Use approved liquid spray solution for bubble test. Ensure that no liquid is sprayed on any electrical components, wires or connectors. Do **not** allow leak detection fluid to contact gas valve regulator or regulator vent opening.
4. Correct any and all deficiencies.
5. Remove air from gas line.

**Connections** *(continued)*

**Heating water connections**

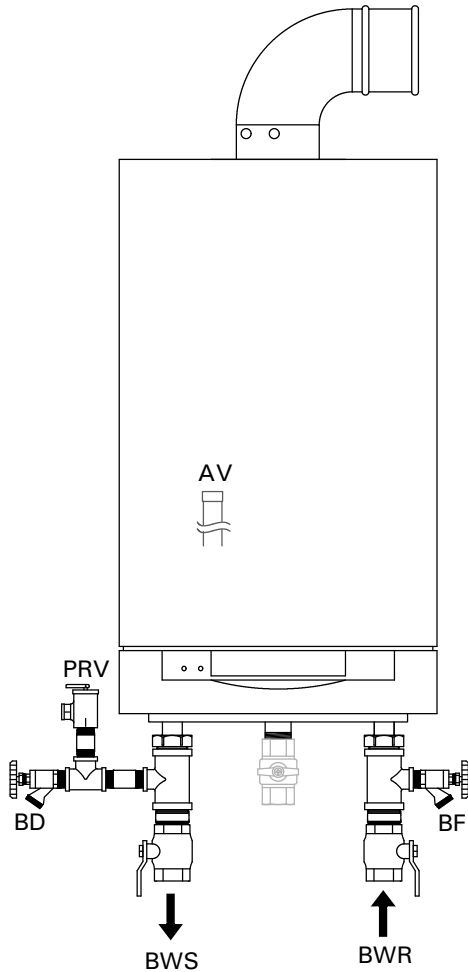

Fig. 14

**Legend**

- AV Air Vent (inside boiler)
- BD Boiler Drain
- BF Boiler Fill
- BWS Boiler Water Supply
- BWR Boiler Water Return
- PRV Pressure Relief Valve

1. Thoroughly flush heating system (particularly before connecting the boiler to an existing system).
2. Connect boiler to the heating system.

Max. operating pressure ..... 4 bar / 60 psig  
 Test pressure ..... 6 bar / 90 psig

**IMPORTANT**

**Damage resulting from pressure exceeding those values stated is not covered by Viessmann warranty.**

**Connections** *(continued)*

**DHW storage tank information**

The DHW water tank sensor is required when using a stand-alone DHW storage tank with the Vitodens 200-W WB2B heating boiler. It comprises the sensor only required for the connection of a stand-alone tank. All other required piping connections are field supplied.

 See *Vitodens 200-W WB2B Start-up/Service Instructions* for applicable system coding information.

**Making the DHW connections**

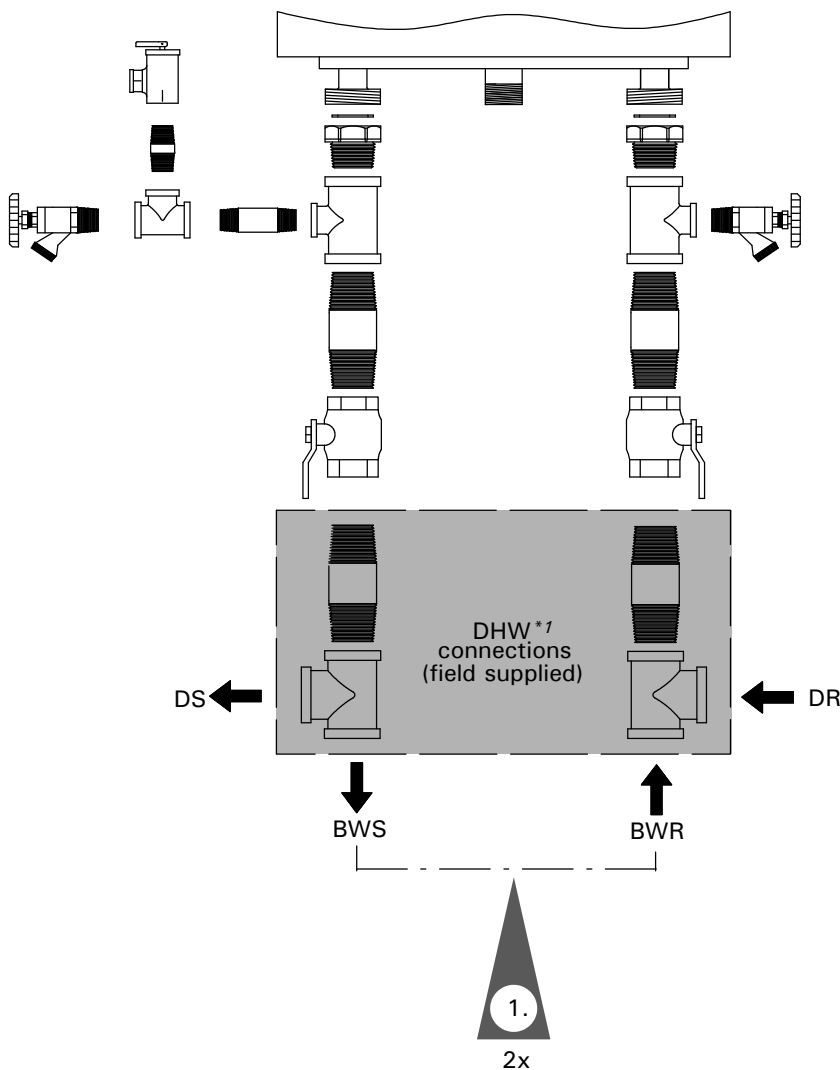

1. Connect field supplied nipples and tees as shown for DHW supply and return.

**IMPORTANT**

Apply sufficient amount of thread sealant (supplied) when making the connections.

*\*1 When using a low loss header in the system, the DHW connections can be made downstream of the low loss header. See page 38 for a general layout of the DHW piping. See Vitodens 200-W WB2B Start-up/Service Instructions for applicable system coding information (see coding level 2 00: ... A2: ... 5b: ...*

- Legend**
- DR Boiler heating return for domestic hot water production 1 ¼" (field supplied)
  - DS Boiler heating supply for domestic hot water production 1 ¼" (field supplied)
  - BWS Boiler Water Supply
  - BWR Boiler Water Return

Fig. 15

## Connections *(continued)*

### Making the DHW connections *(continued)*

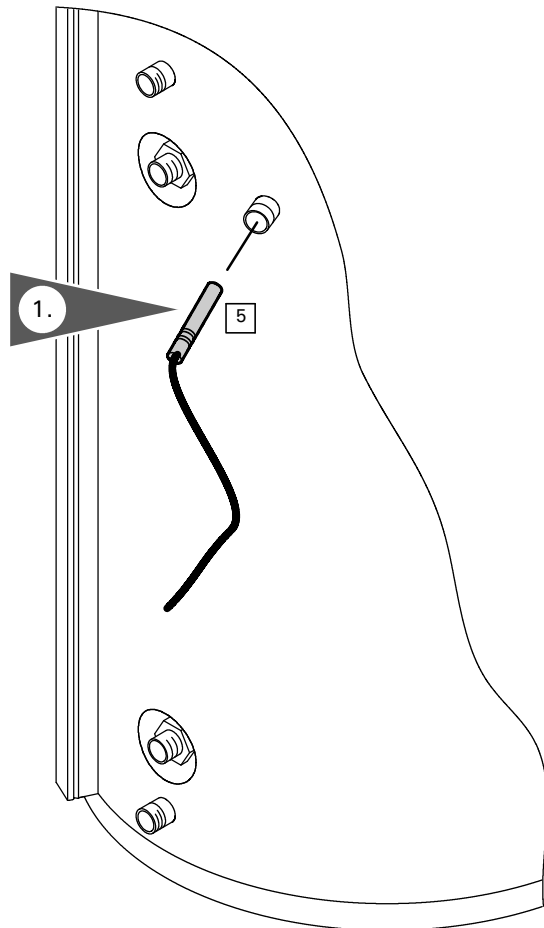

Fig. 16 Vitocell-H 100 DHW storage tank

**1. With a Vitocell 100 DHW storage tank:**

Insert DHW tank temperature sensor **5** into sensor well as shown.

**With a Vitocell 300 DHW storage tank:**

Refer to the Vitocell 300 Installation Instructions shipped with the DHW storage tank for details.

### IMPORTANT

Follow the Installation Instructions supplied with the Viessmann DHW storage tank when mounting and securing DHW tank temperature sensor **5**.

### **!** WARNING

**IF A DHW STORAGE TANK OTHER THAN A VISSMANN VITOCCELL 100 OR 300 TANK IS USED, THE INSTALLER MUST VERIFY PROPER OPERATION OF THE VISSMANN DHW TANK TEMPERATURE SENSOR WITH ORIGINAL MANUFACTURER OF THE TANK. VISSMANN STRONGLY RECOMMENDS THE INSTALLATION OF A TEMPERATURE TEMPERING VALVE IN THE DHW SUPPLY LINE.**

**Connections** *(continued)*

**Accessing the control unit cables**

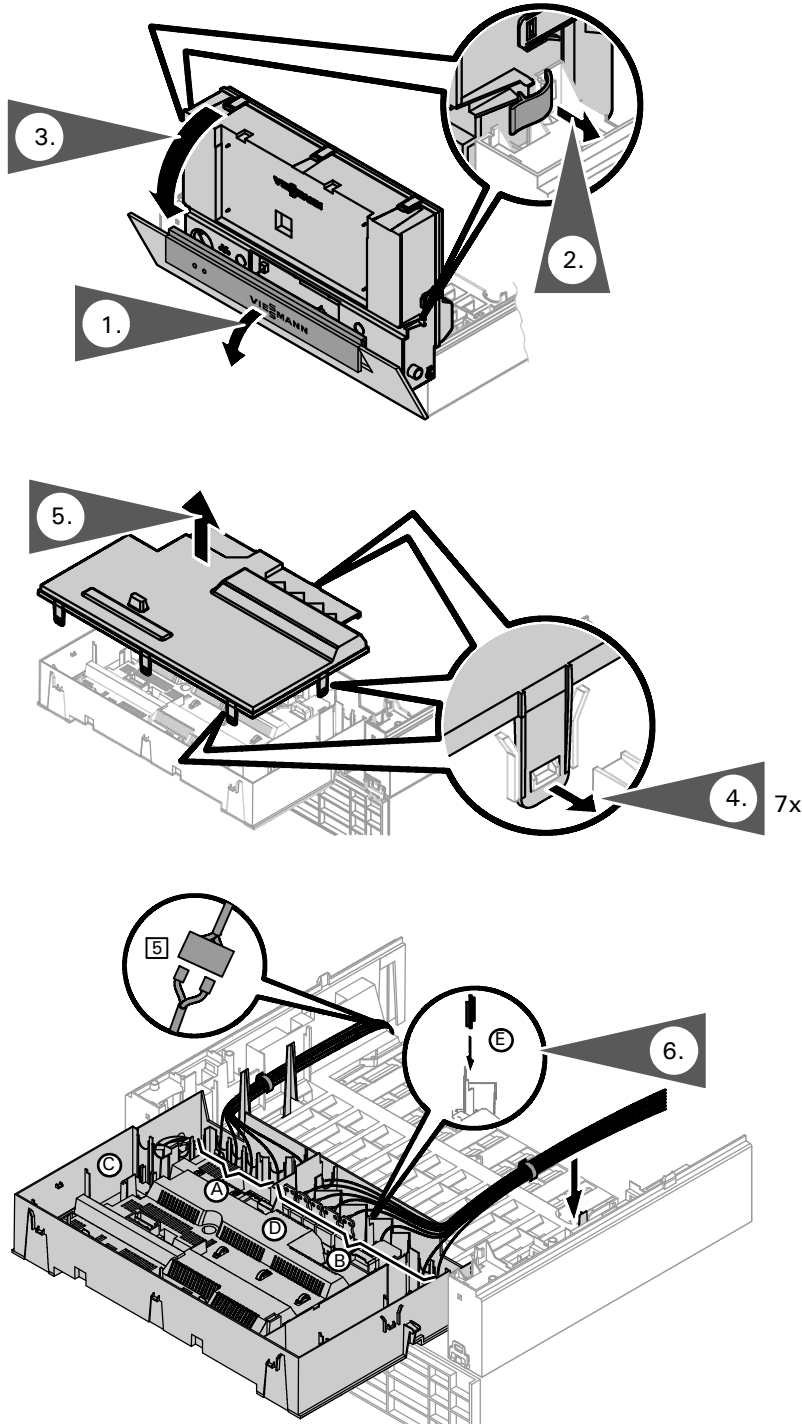

1. To open hinged cover, lift cover and pivot control unit flap down.
2. Release the hinged hooks located on both sides of the control unit.
3. Fold down the control unit.
4. Release locking tabs as shown.
5. Remove cover.

**CAUTION**  
 When running and securing connecting cables on site, ensure that the maximum permissible temperatures of the cables are not exceeded.

6. Route all connecting cables to the appropriate areas and secure the cables to the control base using existing strain reliefs as shown.

- Legend**
- (A) Low voltage connections
  - (B) 230 VAC connections
  - (C) Communications module (accessories)
  - (D) Main PCB
  - (E) Strain relief for power supply cable
  - [5] Plug for connecting the DHW temperature sensor to the cable harness.

Fig. 17

**Connections** *(continued)*

**Connecting DHW sensor**

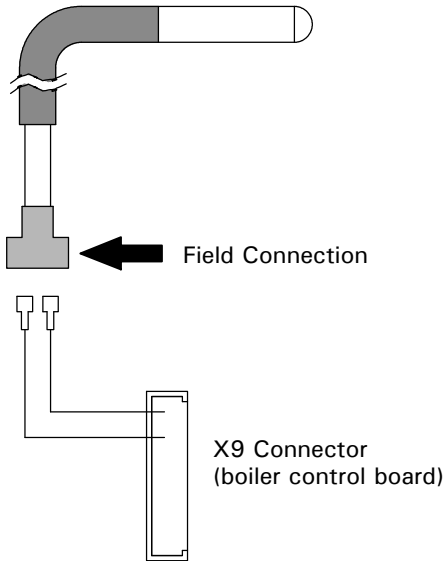

Fig. 18

1. Attach the DHW sensor to the quick connect plugs provided from the boiler control board (see page 22).



*Install DHW tank temperature sensor as described in the Vitocell Installation Instructions supplied with the DHW storage tank.*

**High altitudes setting**

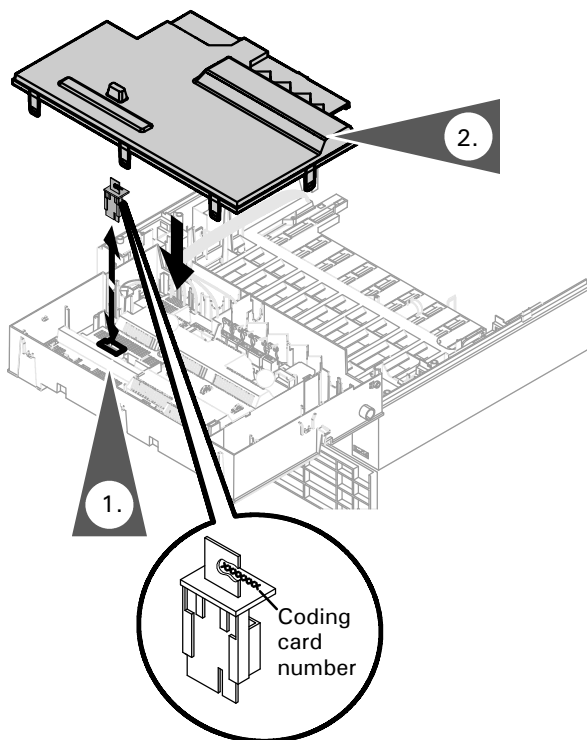

Fig. 19

In the factory default setting, the boiler is equipped to operate in altitudes of up to 5,000 ft. / 1,500 m. For operation in higher altitudes, the existing coding card must be replaced with a higher altitude coding card. See table 2 or the Viessmann Price List for order information.

1. Pull out the existing coding card, cut and remove it from the cable tie. Insert the high altitude coding card into the boiler control board.
2. Install cover.

**Table 2. Altitude coding cards**

Model Number (base serial #)	Coding card Order Number	
	0-5,000 ft. / 0-1,500 m	5,000-10,000 ft. / 1,500 - 3,000 m
WB2B 45 (7374866....)	7832 267 *1 or 7833 227 *1	7425 956 or 7424 905
WB2B 60 (7374867....)	7832 268 *1 or 7833 229 *1	7425 957 or 7424 906

\*1 Factory Installed

## Connections *(continued)*

### Condensate connection

The Vitodens 200-W WB2B boiler comes with a built-in condensate trap. An external trap is not required when connecting the field drain to flexible discharge tubing. Discharge tubing (field supplied) must be of 1" diameter. Use CPVC, PVC or other material approved by codes listed below.

The drain pipe and fittings must conform to ANSI standards and ASTM D1785 or D2846. CPVC or PVC cement and primer must conform to ASTM D2564 or F493. In Canada use CSA or ULC listed schedule 40 CPVC or PVC drain pipe, fittings and cement.

If the condensate outlet of the Vitodens 200-W WB2B boiler is lower than the drain, a condensate pump must be installed. Select a pump which is approved for condensing boiler applications. To avoid condensate spillage, select a pump with an overflow switch. The drain connection must terminate into an open or vented drain as close to the boiler as possible to prevent siphoning of the boiler drain.

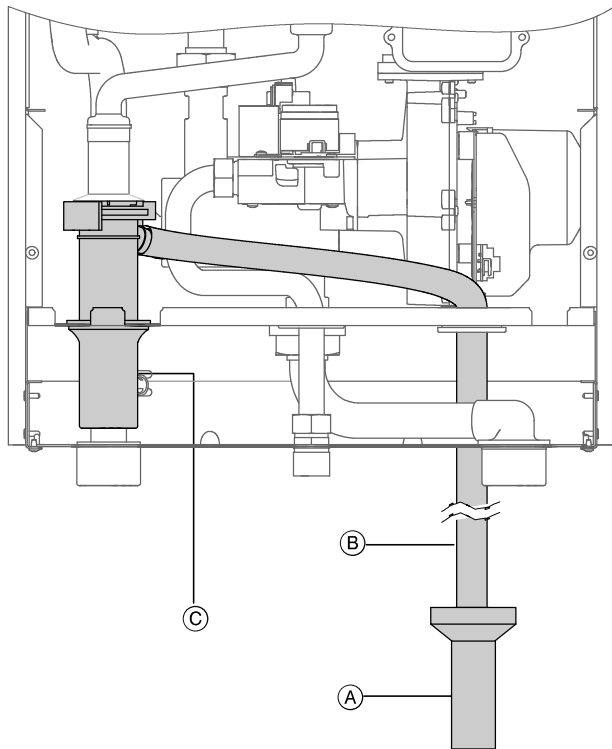

Fig. 20

#### Legend

- (A) Open or vented field supplied drainage system
- (B) Flexible discharge tubing
- (C) Siphon trap

1. Install the condensate drain pipe with a suitable gradient.

#### IMPORTANT

As shipped, the flexible discharge tubing (B) will be found to be pushed up inside the boiler housing. Ensure the condensate drain pipe is pulled down and positioned to allow the condensate to properly drain.

2. Discharge condensate from the boiler into the drainage system, either directly or (if required) via a neutralization unit (accessory).



*Installation Instructions of Neutralization Unit (if applicable)*

#### IMPORTANT

Pipe ventilation must take place between the siphon trap and the neutralization unit (if applicable).

#### IMPORTANT

Do not connect the drain pipe from any other appliance, such as water softener backwash pipe, to Vitodens condensate drain pipe.



# Safety Connections and Pressure Testing

## Installing boiler safety devices

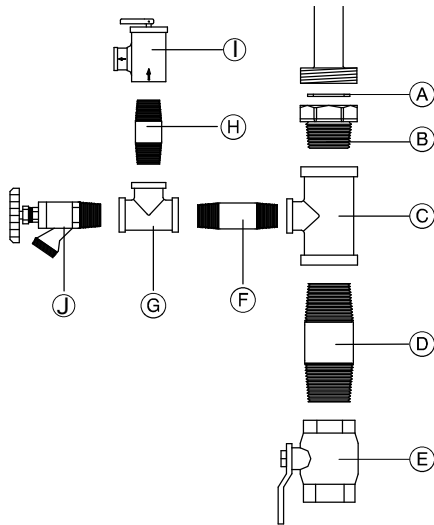

Fig. 21

**Legend**

- Ⓐ Gasket, Ø 1 1/2"
- Ⓑ G 1 1/2" to 1 1/4" NPT adaptor
- Ⓒ Reducing tee, 1 1/4" x 3/4" x 1 1/4"
- Ⓓ Brass nipple, length 2 1/2" x 1 1/4"
- Ⓔ Isolation valve, 1 1/4"
- Ⓕ Brass nipple, length 3" x 3/4"
- Ⓖ Tee
- Ⓗ Brass nipple, length 2" x 3/4"
- Ⓘ Pressure relief valve, 3/4" NPT
- ⓵ Drain valve connection, 3/4"

1. Remove loosely pre-assembled combination pressure relief valve and drain valve assembly.
2. Apply sufficient amount of pipe sealant to both ends of all pipe fittings Ⓑ, Ⓓ, Ⓕ, Ⓗ, ⓵, and Ⓔ and install onto tees Ⓒ, and Ⓖ.
3. Install pressure relief valve Ⓘ and tighten.
4. Install discharge pipe on pressure relief valve in such a way that...
  - the end of the pipe is not threaded.
  - the pressure relief discharge pipe extends to a floor drain and ends approximately 6" / 150 mm above the drain.
 Ensure that...
  - there is no shutoff valve installed in the discharge pipe.
  - discharge pipe diameter is not reduced.
  - discharge is not piped to outdoors.

Minimum connection diameters:

Pressure relief valve .....	3/4"
Discharge pipe .....	3/4"
Piping to precharged expansion tank .....	3/4"

### IMPORTANT

Install the (approved) factory supplied pressure relief valve.

Removal of air from the system must occur via use of air vent(s) in the system supply. To ensure the boiler can be purged of all air, ensure supply/return water lines do not contain restrictive piping where air could be trapped.

**⚠ WARNING**

**Do not install an isolation valve between boiler and pressure relief valve.**

**The discharge pipe for the pressure relief valve must be oriented to prevent scalding of attendants.**

**Pipe pressure relief valve discharge pipe close to floor drain. Never pipe discharge pipe to the outdoors.**

**Low water cut-off**

A low water cut-off may be required by local codes. If boiler is installed above radiation level, a low water cut-off device of approved type (field supplied) must be installed in all instances. Do not install an isolation valve between boiler and low water cut-off (see subsection entitled "Boiler with low water cut-off" on page 40 in these instructions).

## Safety Connections and Pressure Testing *(continued)*

### Performing a boiler pressure test

The boiler must be leak tested before being placed in operation. Before boiler is connected to piping or electrical power supply, it must be hydrostatically pressure tested.

1. After installing safety devices (see previous page), install temporary cap on 3/4" x 2" nipple.
2. Cap supply and return connections.
3. Connect 1/2" garden hose to boiler fill valve at the bottom of the boiler and fill boiler slowly until pressure gage indicates max. 4 bar / 60 psig.
4. Maintain pressure for 15 minutes. During time of pressure testing, do not leave boiler unattended.
5. Inspect all pipe joint connections and safety devices with a flashlight for leaks.  
A lower manometer reading than 4 bar / 60 psig usually indicates loss of water due to leakage. All leaks must be repaired.
6. After 15 minutes, release water pressure from boiler by opening boiler drain valve slowly, remove caps from supply and return connections as well as 3/4" cap from 2" nipple, and install pressure relief valve immediately instead of 3/4" cap.
7. After boiler has passed pressure test, proceed with the installation.

Max. operating pressure	4 bar / 60 psig
Testing pressure	6 bar / 90 psig
Max. boiler water temperature	210°F / 99°C

 **WARNING**  
Exposing the boiler to pressures and temperatures in excess of those listed will result in damages, and will render warranty null and void.

## Installation Examples

### General

The schematics on the following pages are to be seen as guidelines only. They further do not display all system varieties, safety devices, or concepts possible. Specific system layouts may be further discussed with the local Viessmann sales representative office.

### Clearances

A minimum of 2" / 51 mm circumferential clearance from non-insulated hot water pipes to combustible construction must be maintained. In cases where the pipes are insulated with pipe insulation of appropriate and sufficient thickness and insulation values, the above clearance may be reduced to 0" (refer to local gas codes).

### CAUTION

For underfloor heating applications, an additional immersion or strap-on aquastat must be installed in the low temperature underfloor loop (downstream of the mixing valve) to de-energize the pump and/or boiler to prevent overheating. High water temperatures can damage concrete slabs.

*Please note that in the following piping layout examples all pumps are field supplied.*

### IMPORTANT

The examples on the following pages depict possible piping layouts of the Vitodens 200-W WB2B boiler equipped with Viessmann System Technology. For boiler and tank combinations, please install only feasible combinations listed in the Viessmann Price List.

Please note that the following examples are simplified conceptual drawings only!

Piping and necessary componentry must be field verified.

A low water cut-off (LWCO) must be installed where required by local codes. Proper installation and functionality in the field is the responsibility of the heating contractor.

### WARNING

If a DHW storage tank other than a Viessmann Vitocell 100 or 300 tank is used, the installer must verify proper operation of the Viessmann DHW tank temperature sensor with the original manufacturer of the tank. Viessmann strongly recommends the installation of a temperature tempering valve in the DHW supply line.

### IMPORTANT

DHW supply and return piping between boiler DHW connections and the Viessmann DHW tank connections, shall be a minimum of 1¼" pipe size. This will ensure the residual head of the field supplied pump is fully utilized to overcome the resistance of the DHW heat exchanger coil and to provide sufficient water flow to the boiler heat exchanger.

In non-Viessmann DHW tank applications, perform, in addition to the above, accurate calculations for DHW tank coil pressure drop versus boiler pump (field supplied) residual head to ensure sufficient water flow to the boiler heat exchanger. Failure to heed the above instructions may cause boiler short-cycling and inadequate DHW supply.

**Installation Examples** *(continued)*

**Waterside flow (primary circuit)**

The Vitodens 200-W, WB2B is designed for closed loop, forced circulation hot water heating systems only.

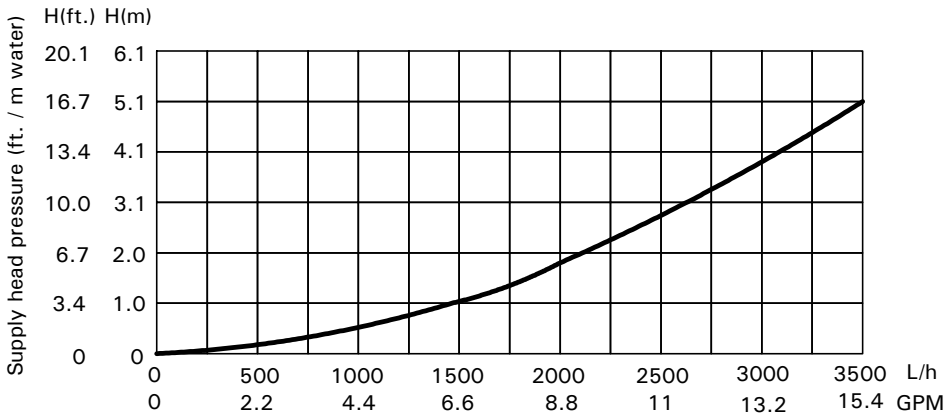

**Pressure drop (primary circuit) for Vitodens 200-W, WB2B 45, 60**  
 For sizing an on-site circulation system.  
 Max. flow rate 15.4 USGPM/3500 L/h.

Fig. 22

Use standard friction loss method for pipe sizing. Observe boiler maximum and minimum flow rate limitations. If system flow rate exceeds boiler maximum flow rate (as stated above), falls below the minimum flow rate or if system flow rate is unknown, Viessmann strongly recommends the installation of a low-loss header.

**Table 3. Typical System Flow Rates**

Model	WB2B	45	60
$\Delta t$ for NG/LPG			
<b>Output (NG/LPG) MBH</b>		146	194
20°F rise (GPM)		14.6	19.4
25°F rise (GPM)		11.7	15.5
30°F rise (GPM)		9.7	12.9
35°F rise (GPM)		8.3	11.1
40°F rise (GPM)		7.3	9.7

**Boilers max. flow rate** 15.4 USGPM / 3500 L/h.

An alternative method may be used, such as primary secondary piping using closely spaced tees. A low-loss header offers additional benefits not provided by a pair of closely spaced tees. Viessmann therefore strongly recommends and prefers the use of a low-loss header over closely spaced tees. Refer to the Technical Data manual for low-loss header information.

5418 909 v1.6

**Installation Examples** *(continued)*

**System layout 1**

**Vitodens 200-W, WB2B with a direct-connected heating circuit**

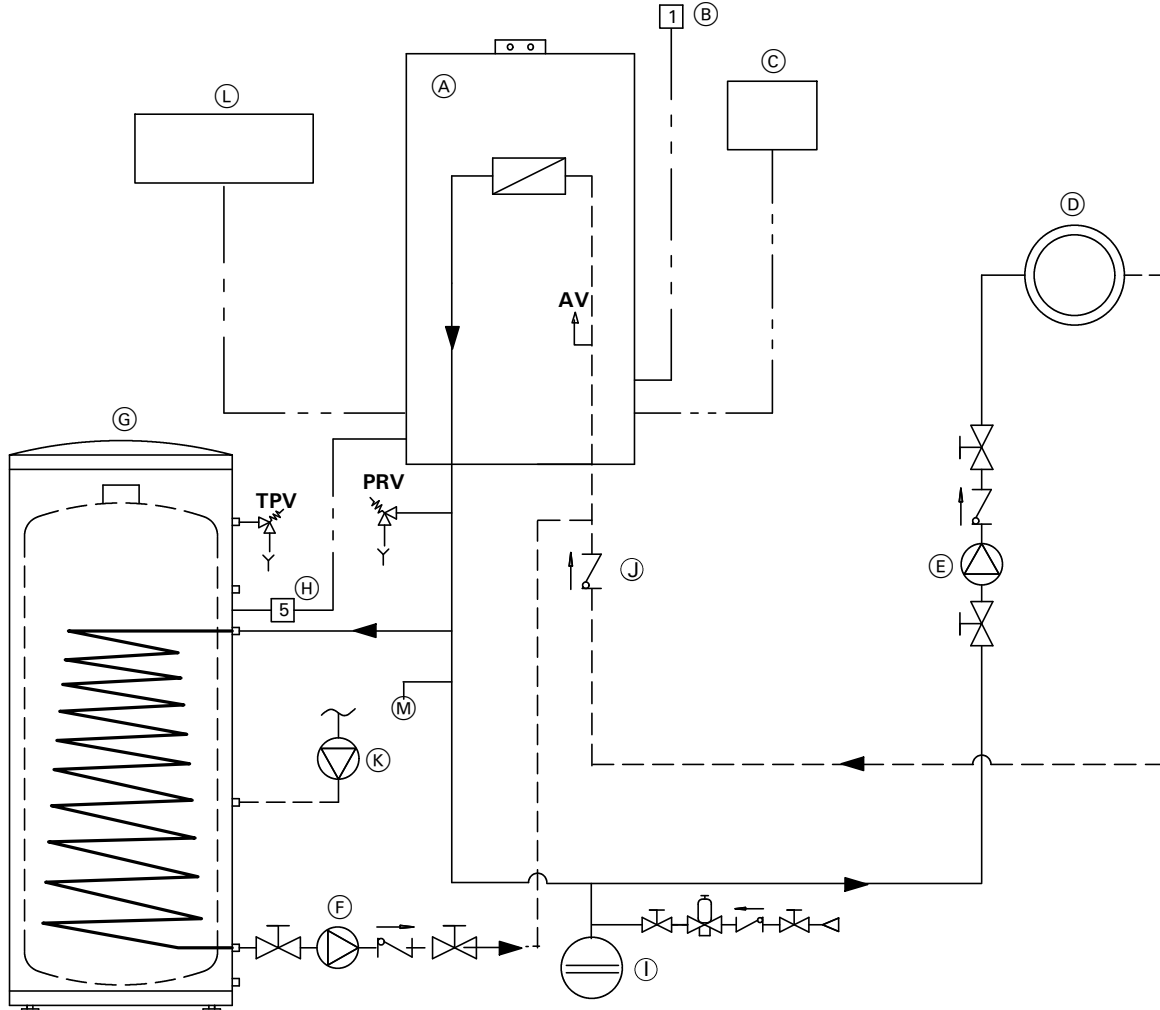

Fig. 23

**Legend**

- AV** Air vent (models WB2B 45, 60)
- PRV** Pressure relief valve
- TPV** Temperature and pressure relief valve
- (A)** Vitodens 200-W WB2B boiler with Vitotronic 200, HO1 outdoor reset control
- (B)** Outdoor temperature sensor [1]
- (C)** Remote control Vitotrol 300 (optional)
- (D)** Heating circuit
- (E)** Heating circuit pump [20]\*
- (F)** DHW circulating pump [21]\*
- (G)** DHW storage tank
- (H)** DHW tank temperature sensor [5]
- (I)** Expansion tank
- (J)** Flow check valve
- (K)** DHW recirculation pump [28]\*
- (L)** Power/Pump module
- (M)** Optional purge tee (field supplied)

**Installation of ...**

- radiator heating circuit (high-temp. circuit)
- DHW production

**... with the following flow conditions:**  
 The flow rate of the heating circuit is **less** than the maximum possible water flow rate of the Vitodens 200-W WB2B boiler (see page 28 for maximum water flow rate of boiler).

The use of a low-loss header is strongly recommended if the maximum water flow rate in the application concerned exceeds the values shown in the applicable table on page 28, or if the system flow rates are unknown.  
 The low-loss header is available as accessory part.

*See following pages for installation examples with a low-loss header.*

**IMPORTANT**

DHW circulating pump **(F)** must pump *into* the Vitodens 200-W boiler (as illustrated).

\* See pages 53 and 57.

# Installation Examples *(continued)*

## System layout 2

Vitodens 200-W, WB2B with a direct-connected heating circuit and low-loss header

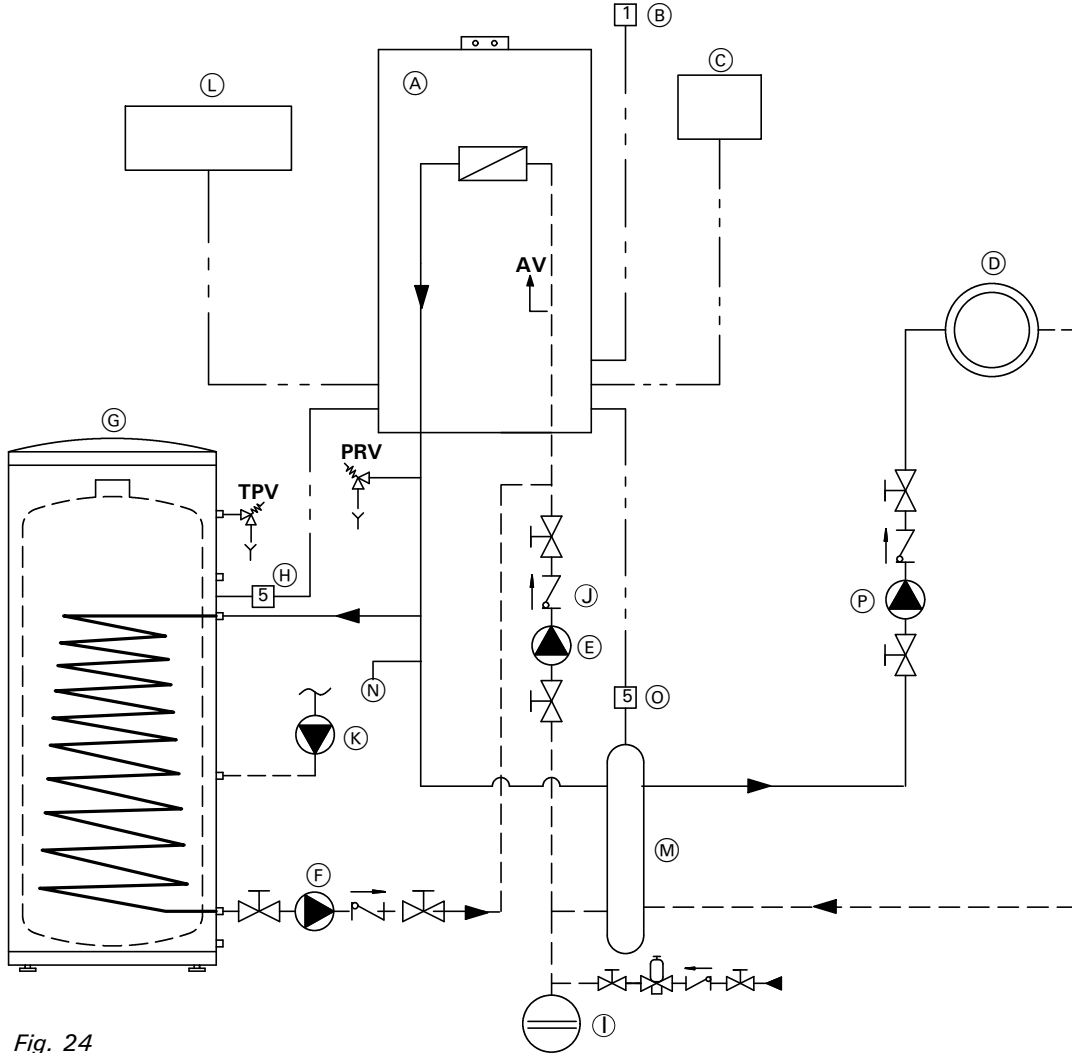

Fig. 24

**Legend**

- AV** Air vent (models WB2B 45, 60)
- PRV** Pressure relief valve
- TPV** Temperature and pressure relief valve
- (A)** Vitodens 200-W WB2B boiler with Vitotronic 200, HO1 outdoor reset control
- (B)** Outdoor temperature sensor [1]
- (C)** Remote control Vitotrol 300 (optional)
- (D)** Heating circuit
- (E)** Boiler pump [20]\*
- (F)** DHW circulating pump [21]\*
- (G)** DHW storage tank
- (H)** DHW tank temperature sensor [5]
- (I)** Expansion tank
- (J)** Flow check valve
- (K)** DHW recirculation pump [28]\*
- (L)** Power/Pump Module
- (M)** Low-loss header
- (N)** Optional purge tee (field supplied)
- (O)** Viessmann temperature sensor for low-loss header [5]

**(P)** Heating circuit pump [20A]\*

\* See pages 53 and 57.

**Installation of ...**

- radiator heating circuit (high-temp. circuit)
  - DHW production
- ... with the following flow conditions:**  
 The flow rate of the heating circuit is **greater** than the maximum possible water flow rate of the Vitodens 200-W WB2B boiler (see page 28 for maximum water flow rate of boiler).  
 The use of a low-loss header is strongly recommended if the maximum water flow rate in the application concerned exceeds the values shown on page 28, or if the system flow rates are unknown.  
 The low-loss header is available as accessory part.

**IMPORTANT**

Please note location of expansion tank (I) and flow check valve (J).

**IMPORTANT**

DHW circulating pump (F) must pump *into* the Vitodens 200-W WB2B boiler (as illustrated).

**Installation Examples** *(continued)*

**System layout 3**

**Vitodens 200-W, WB2B with...**

- DHW storage tank
- one heating circuit with mixing valve and system separation

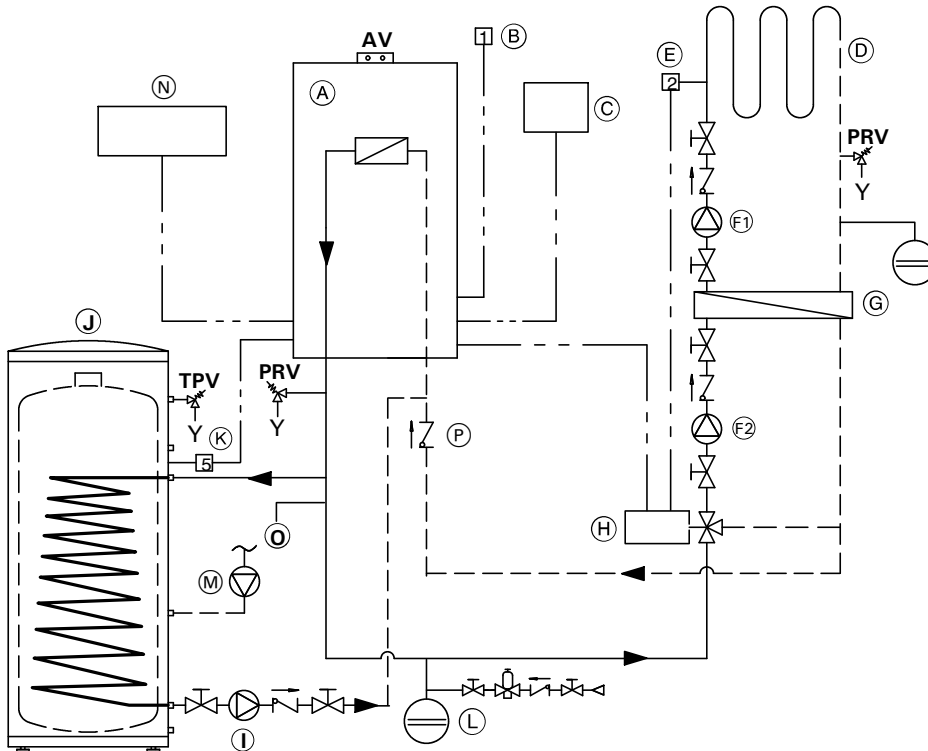

Fig. 25

**Legend**

- AV** Air vent (WB2B models 45, 60)
- PRV** Pressure relief valve
- TPV** Temperature and pressure relief valve
- (A)** Vitodens 200-W WB2B boiler with Vitotronic 200, HO1 outdoor reset control
- (B)** Outdoor temperature [1]
- (C)** Remote control Vitotrol 300 (optional)
- (D)** Underfloor heating circuit
- (E)** Mixing valve temperature sensor [2]
- (F1)** Heating circuit pump
- (F2)** Heating circuit pump located upstream of heat exchanger (see IMPORTANT note to the right)
- (G)** Plate heat exchanger for system separation
- (H)** Accessory kit for heating circuit with mixing valve
- (I)** DHW circulating pump [21]\*
- (J)** DHW storage tank
- (K)** DHW tank temperature sensor [5]
- (L)** Expansion tank
- (M)** DHW recirculation pump [28]\*
- (N)** Power/Pump module
- (O)** Optional purge tee (field supplied)
- (P)** Flow check valve

**Installation of ...**

- underfloor heating circuit with 3-way mixing valve and system separation (low-temp. circuit)
- DHW production

**... with the following flow conditions:**  
 The flow rate of the heating circuit is **less** than the maximum possible water flow rate of the Vitodens 200-W WB2B boiler. See page 28 for maximum water flow rate of the Vitodens 200-W WB2B boilers.  
 The use of a low-loss header is recommended if the system water flow rate is unknown. The low-loss header is available as accessory part.

*See following pages for installation examples with a low-loss header.*

**IMPORTANT**

**System separation is required of underfloor heating systems employing non-oxygen diffusion barrier tubing. All components on the secondary side of the heat exchanger must be made of corrosion-resistant materials.**

**IMPORTANT**

**DHW circulating pump (I) must pump into the Vitodens 200-W WB2B boiler (as illustrated).**

**IMPORTANT**

**Sizing of field-supplied pump (F2) is critical for proper boiler operation in this system layout. The performance of the selected pump must be equivalent or better than those shown on page 28 of this manual. An undersized pump may cause short-cycling and/or improper operation of the boiler. Viessmann STRONGLY recommends using a low-loss header and a boiler pump in this system layout.**

\* See pages 53 and 57.

**Installation Examples** *(continued)*

**System layout 4**

- Vitodens 200-W, WB2B with...**
- DHW storage tank
  - one direct-connected heating circuit
  - one heating circuit with a mixing valve

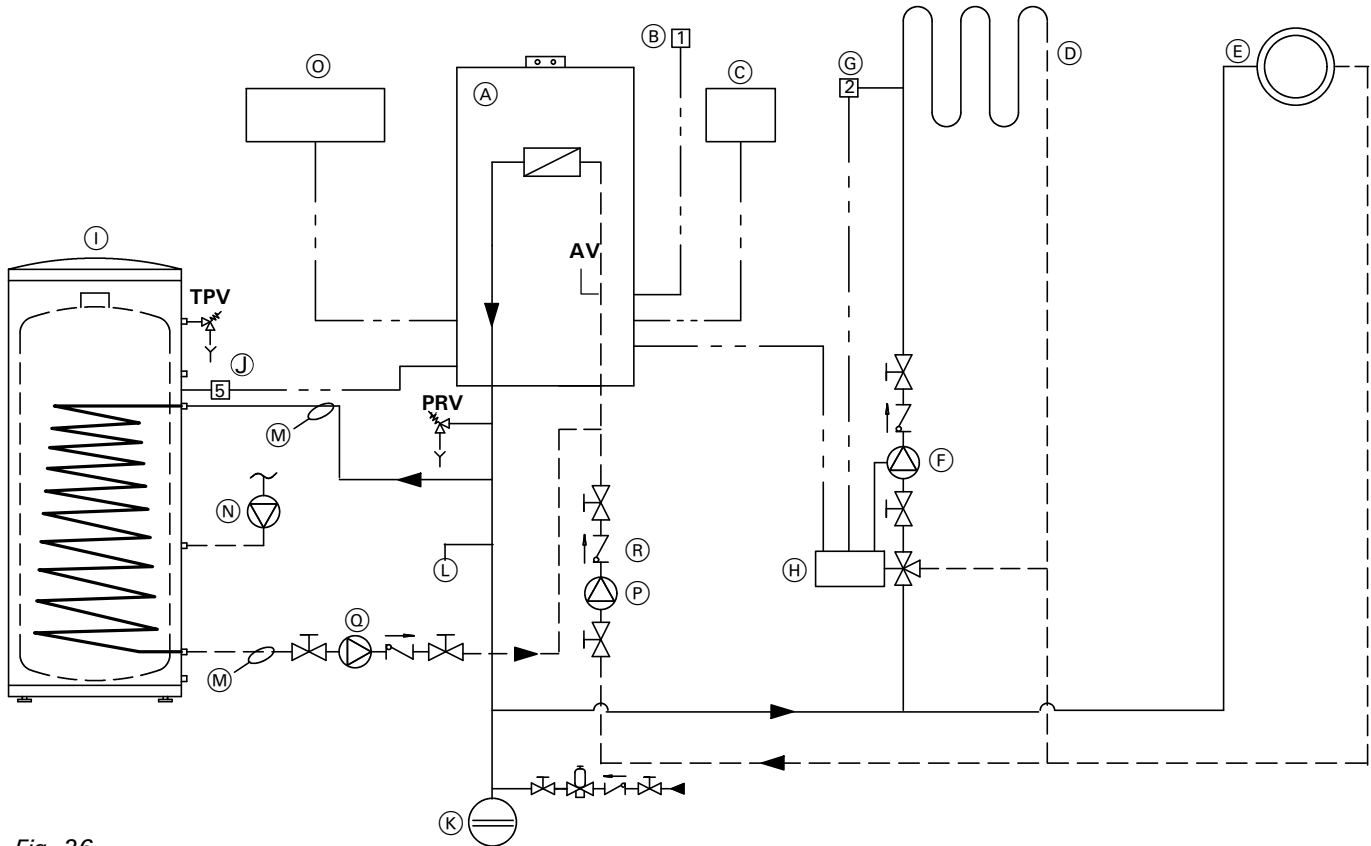

Fig. 26

**Legend**

- AV** Air vent (WB2B models 45, 60)
- PRV** Pressure relief valve
- TPV** Temperature and pressure relief valve
- (A)** Vitodens 200-W WB2B boiler with Vitotronic 200, HO1 outdoor reset control
- (B)** Outdoor temperature sensor [1]
- (C)** Remote control Vitotrol 300 (optional)
- (D)** Under floor heating circuit
- (E)** Radiator heating circuit
- (F)** Heating circuit pump
- (G)** Mixing valve temperature sensor [2]
- (H)** Accessory kit for heating circuit with mixing valve
- (I)** Domestic hot water storage tank
- (J)** DHW tank temperature sensor [5]
- (K)** Expansion tank
- (L)** Optional purge tee (field supplied)
- (M)** DHW supply and return piping
- (N)** DHW recirculation pump [28]\*
- (O)** Power/Pump module
- (P)** Boiler pump [20]\*
- (Q)** DHW circulating pump [21]\*
- (R)** Flow check valve

\* See pages 53 and 57.

**Installation of different heating circuits...**

- radiator heating circuit (high-temp. circuit)
- under floor heating circuit with 3-way mixing valve (low-temp. circuit)
- DHW production

**... with the following flow conditions:**

1. The water flow rate (output) of the radiator heating circuit is at least 30% greater than that of the under floor heating circuit.
  2. The total flow rate of the two heating circuits is **less** than the maximum possible water flow rate of the Vitodens 200-W WB2B boiler (see page 28 for max. water flow rate).
- The use of a low-loss header is strongly recommended if the maximum water flow rate in the application concerned exceeds the values shown on page 28, or if the system flow rates are unknown. The low-loss header is available as accessory part.

See following pages for additional installation examples with a low-loss header.

The 3-way mixing valve, built-in to achieve the low-temperature level of the under floor heating circuit, is controlled by an accessory kit for a heating circuit with mixing valve.

**IMPORTANT**

**DHW circulating pump (Q) must pump into the Vitodens 200-W WB2B boiler (as illustrated).**



**Installation Examples** *(continued)*

**System layout 5**

**Vitodens 200-W, WB2B with...**

- DHW storage tank
- one heating circuit with mixing valve
- one heating circuit without mixing valve and with low-loss header

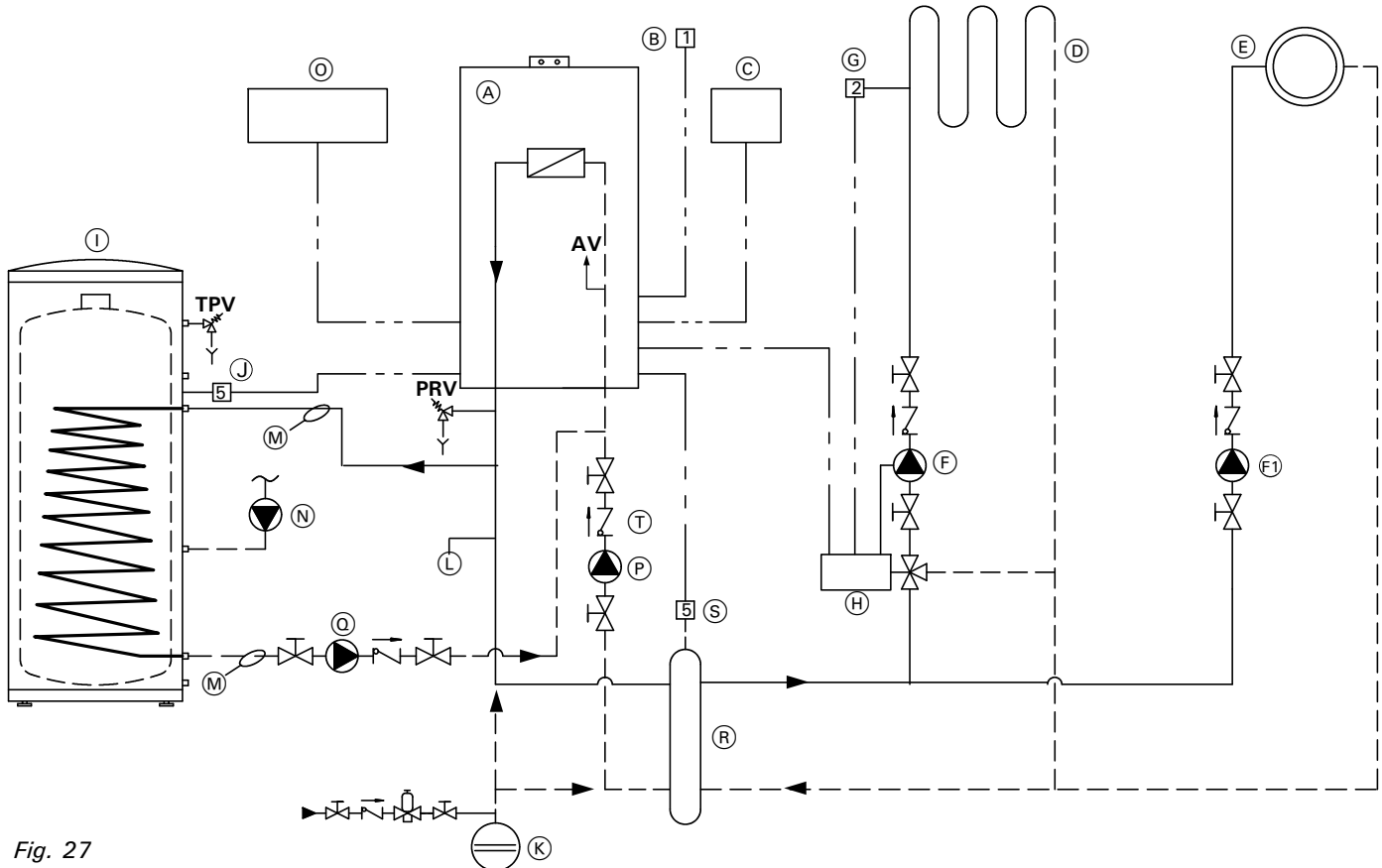

Fig. 27

**Legend**

- AV Air vent (WB2B models 45, 60)
- PRV Pressure relief valve
- TPV Temperature and pressure relief valve
- (A) Vitodens 200-W WB2B boiler with Vitotronic 200, HO1 outdoor reset control
- (B) Outdoor temperature sensor [1]
- (C) Remote control Vitotrol 300 (optional)
- (D) Under floor heating circuit
- (E) Radiator heating circuit
- (F) Heating circuit pump [20A]\*
- (F1) Heating circuit pump
- (G) Mixing valve temperature sensor [2]
- (H) Kit for heating circuit with mixing valve
- (I) Domestic hot water storage tank
- (J) DHW tank temperature sensor [5]
- (K) Expansion tank
- (L) Optional purge tee (field supplied)
- (M) DHW supply and return piping
- (N) DHW circulating pump [28]\*
- (P) Power/Pump module
- (20) Boiler pump [20]\*
- (Q) DHW circulating pump [21]\*
- (R) Low-loss header

- (S) Viessmann temperature sensor for low-loss header [5]
- (T) Flow check valve

\* See pages 53 and 57.

**Installation of different heating circuits...**

- radiator heating circuit (high-temp. circuit)
  - under floor heating circuit with 3-way mixing valve (low-temp. circuit)
  - DHW production
- ... with the following flow conditions:  
 The total flow rate of the two heating circuits is **greater** than the maximum possible water flow rate of the Vitodens 200-W WB2B boiler (see page 28 for maximum water flow rate of boiler).  
 The use of a low-loss header is strongly recommended. The low-loss header is available as accessory part.

The 3-way mixing valve, built-in to achieve the low-temperature level of the under floor heating circuit, is controlled by an accessory kit for a heating circuit with mixing valve.

**IMPORTANT**

Please note location of expansion tank (K) and flow check valve (T).

**IMPORTANT**

DHW circulating pump (Q) must pump into the Vitodens 200-W WB2B boiler (as illustrated).

# Installation Examples *(continued)*

## System layout 6

Vitodens 200-W, WB2B with...  
 - DHW storage tank  
 - two heating circuits with a mixing valve and low-loss header

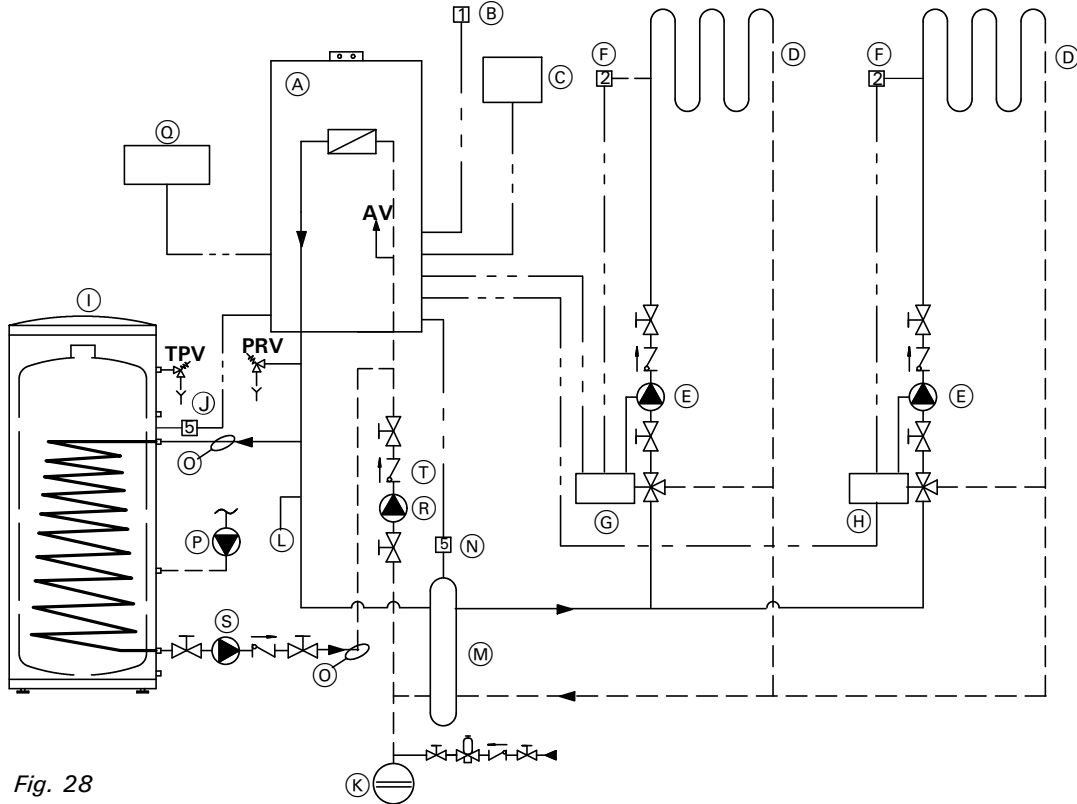

Fig. 28

**Legend**

- AV** Air vent (WB2B models 45, 60)
- PRV** Pressure relief valve
- TPV** Temperature and pressure relief valve
- (A)** Vitodens 200-W WB2B boiler with Vitotronic 200, HO1 outdoor reset control
- (B)** Outdoor temperature sensor [1]
- (C)** Remote control Vitotrol 300 (optional)
- (D)** Under floor heating circuit
- (E)** Heating circuit pumps
- (F)** Mixing valve temperature sensor [2]
- (G)** Accessory kit for heating circuit with mixing valve
- (H)** Vitotronic 200-H, HK1M with LON communication module\*<sup>1</sup>
- (I)** DHW storage tank
- (J)** DHW tank temperature sensor [5]
- (K)** Expansion tank
- (L)** Optional purge tee (field supplied) for easier air removal
- (M)** Low-loss header
- (N)** Viessmann temperature sensor for low-loss header [5]
- (O)** DHW supply and return piping
- (P)** DHW circulating pump [28]\*
- (Q)** Power/Pump Module
- (R)** Boiler pump [20]\*
- (S)** DHW circulating pump [21]\*

(T) Flow check valve

\* See pages 53 and 57.

**Installation of different heating circuits...**

- two heating circuits with 3-way mixing valve (low-temp. circuit)
- DHW production

**... with the following flow conditions:**

The total flow rate of the two heating circuits is **greater** than the maximum possible water flow rate of the Vitodens 200-W WB2B boiler (see page 28 for maximum water flow rate of boiler). The use of a low-loss header is strongly recommended. The low-loss header is available as accessory part.

The 3-way mixing valve, built-in to achieve the low-temperature level of the under floor heating circuit, is controlled by an accessory kit for a heating circuit with mixing valve (G). The second under floor heating circuit is supplied by a field supplied circulation controlled by an accessory kit or a Vitotronic 200-H, HK1M mixing valve control (H). If more than two heating circuits with mixing valves are to be connected, they can be controlled by a Vitocontrol

multi-boiler control. Contact your local Viessmann Technical Sales Representative for details.

\*<sup>1</sup> Requires...

- LON communication module 200-H HK1M
- Boiler LON communication module
- LON cable
- End resistors

**IMPORTANT**

Please note location of expansion tank (K) and flow check valve (T).

**IMPORTANT**

DHW circulating pump (S) must pump *into* the Vitodens 200-W WB2B boiler (as illustrated).

**Installation Examples** *(continued)*

**System layout 7**

**Vitodens 200-W, WB2B with...**

- direct-connected heating circuit
- one heating circuit with system separation

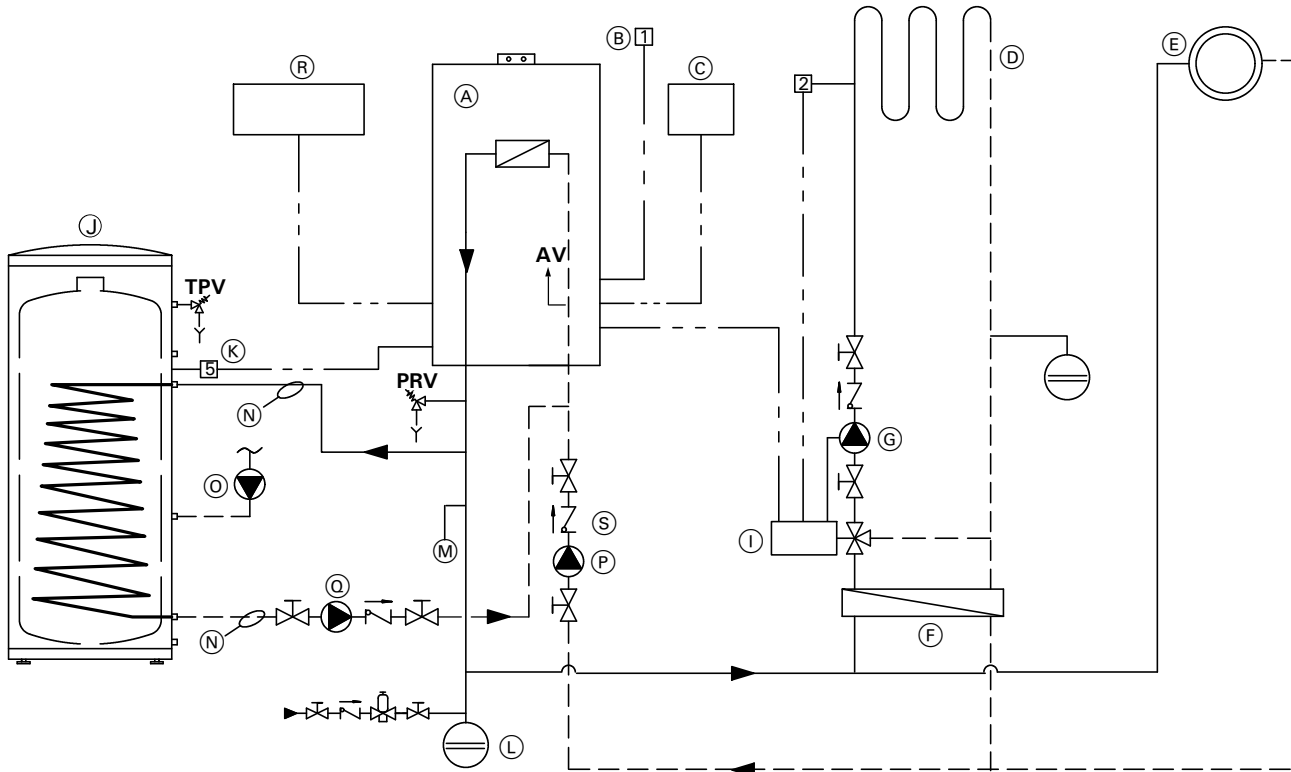

Fig. 29

**Legend**

- AV Air vent (WB2B models 45, 60)
- PRV Pressure relief valve
- TPV Temperature and pressure relief valve
- (A) Vitodens 200-W WB2B boiler with Vitotronic 200, HO1 outdoor reset control
- (B) Outdoor temperature sensor [1]
- (C) Remote control Vitotrol 300 (optional)
- (D) Under floor heating circuit
- (E) Heating circuit pump
- (F) Plate heat exchanger for system separation
- (G) Heating circuit pump
- (H) Mixing valve temperature sensor [2]
- (I) Accessory kit for heating circuit with mixing valve
- (J) DHW storage tank
- (K) DHW tank temperature sensor [5]
- (L) Expansion tanks
- (M) Optional purge tee (field supplied)
- (N) DHW supply and return piping
- (O) DHW recirculation pump [28]\*
- (P) Boiler pump [20]\*
- (Q) DHW circulating pump [21]\*
- (R) Power/pump module
- (S) Flow check valve

\* See pages 53 and 57.

**Installation of different heating circuits...**

- radiator heating circuit (high-temp. circuit)
- under floor heating circuit with 3-way mixing valve (low-temp. circuit)
- DHW production

**... with the following flow conditions:**

The total flow rate of the two heating circuits is **less** than the maximum possible water flow rate of the Vitodens 200-W WB2B boiler (see page 28 for maximum water flow rate of boiler).  
 The use of a low-loss header is strongly recommended if the maximum water flow rate in the application concerned exceeds the max. boiler flow rate, or if the system flow rates are unknown. The low-loss header is available as accessory part.  
 The 3-way mixing valve, built-in to achieve the low-temperature level of the under floor heating circuit, is controlled by an accessory kit for a heating circuit with mixing valve (I). The boiler pump [20] supplies the radiator heating circuit and the plate heat exchanger for system separation.

**IMPORTANT**

The pressure drop (secondary circuit) of the plate heat exchanger (F) must be less/equal to the pressure drop of the 3-way mixing valve. This must be taken into account when sizing the plate heat exchanger.

**IMPORTANT**

DHW circulating pump (Q) must pump into the Vitodens 200-W WB2B boiler (as illustrated).

# Installation Examples *(continued)*

## System layout 8

- Vitodens 200-W, WB2B with...**
- DHW storage tank
  - low-loss header
  - multiple heating circuits with mixing valves

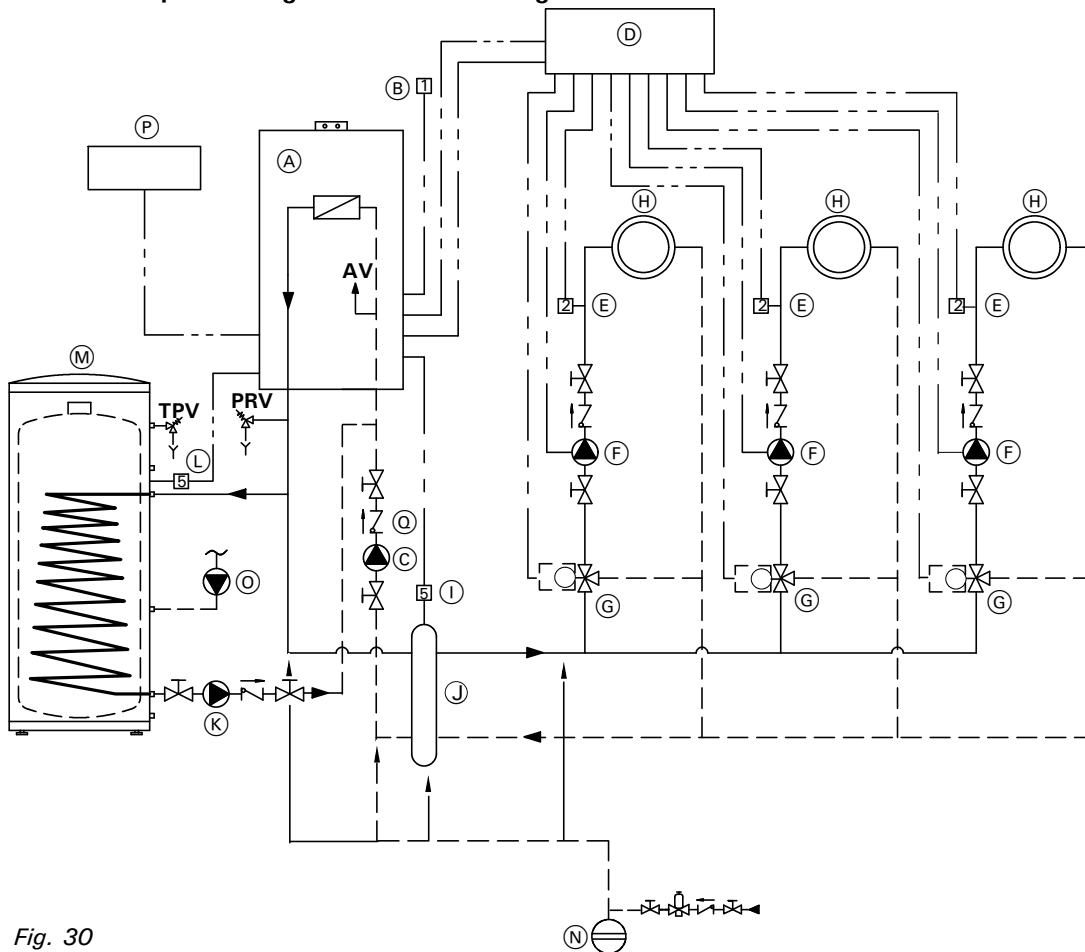

Fig. 30

When designing a system as illustrated above, please contact your local Viessmann Sales Representative for assistance.

**Legend**

- AV** Air vent (WB2B models 45, 60)
- PRV** Pressure relief valve
- TPV** Temperature and pressure relief valve
- (A)** Vitodens 200-W WB2B boiler with Vitotronic 200, HO1 outdoor reset control
- (B)** Outdoor temperature [1]
- (C)** Boiler pump [20]\*
- (D)** Vitocontrol or Vitotronic 200-H, \*1
- (E)** Mixing valve temperature sensor [2]
- (F)** Heating circuit pumps
- (G)** Accessory kit for heating circuit with mixing valve \*2
- (H)** Heating circuits with mixing valves
- (I)** Viessmann temperature sensor for low-loss header [5]
- (J)** Low-loss header
- (K)** DHW circulating pump [21]\*
- (L)** DHW tank temperature sensor [5]

- (M)** DHW storage tank
- (N)** Expansion tank
- (O)** DHW recirculation pump [28]\*
- (P)** Power/Pump module
- (Q)** Flow check valve

\* See pages 53 and 57

\*1 Contact your local Sales Representative for details.

\*2 Vitotronic 200-H, HK1M mixing valve control with LON communication module can be used instead of the accessory kit and Vitocontrol.

**IMPORTANT**

Please note location of expansion tank (N) and flow check valve (O).

**IMPORTANT**

Pumps (C) and (K) must pump into the Vitodens 200-W WB2B boiler (as illustrated).

## Installation Examples *(continued)*

### System layout 9

Multiple (up to four) Vitodens 200-W, models WB2B 45 to 105 with...

- multiple heating circuits with mixing valves
- low-loss header

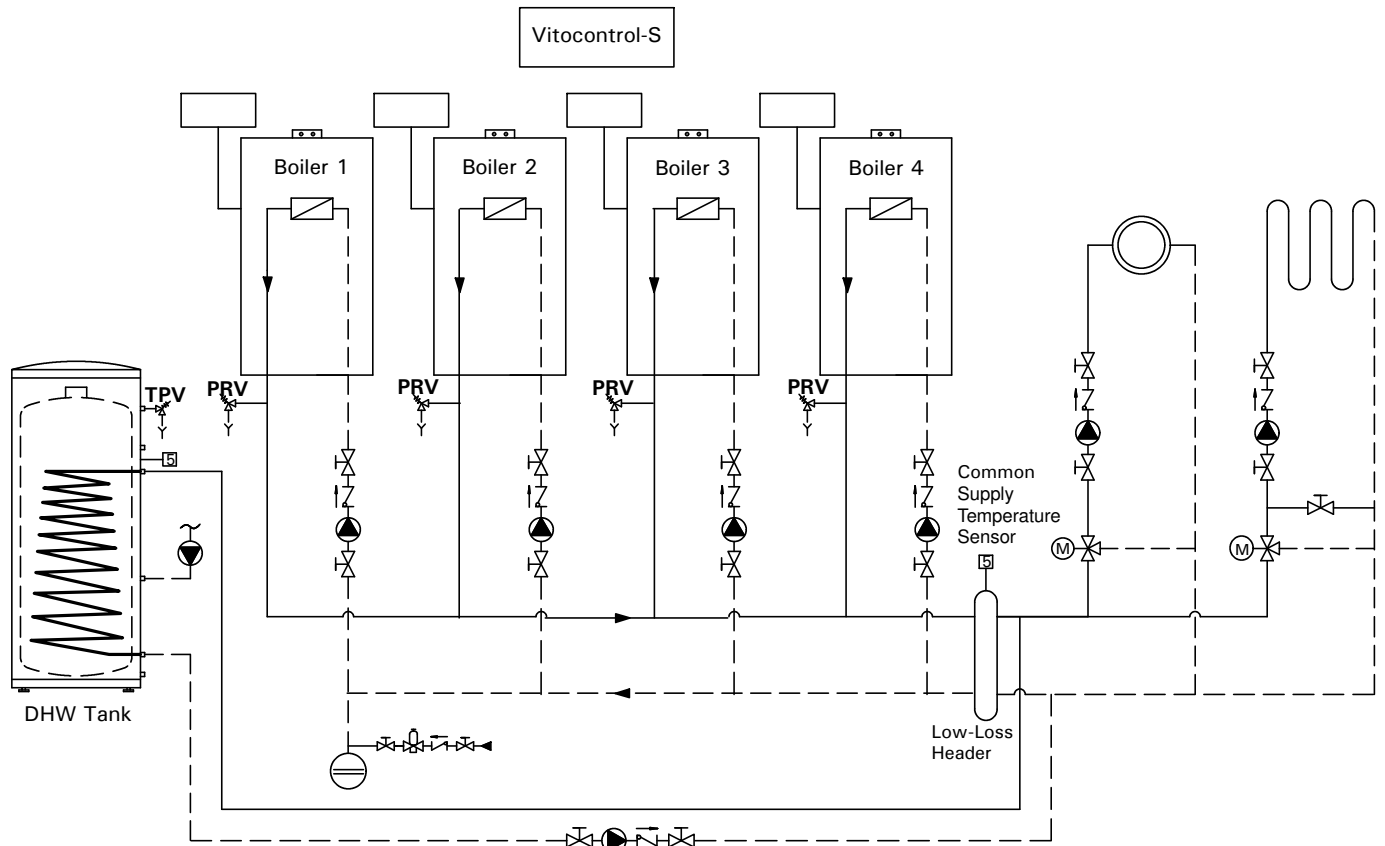

Fig. 31

### IMPORTANT

This installation example depicts a possible piping layout for multiple Vitodens 200-W, WB2B boilers equipped with Viessmann System Technology. Please note that this example is based on a simplified conceptual drawing only! Piping and necessary componentry must be field verified.

A low water cut-off (LWCO) must be installed where required by local codes. Proper installation and functionality in the field is the responsibility of the heating contractor.



### WARNING

If a DHW storage tank other than a Viessmann Vitocell 100 or 300 tank is used, the installer must verify proper operation of the Viessmann DHW tank temperature sensor with the original manufacturer of the tank. Viessmann strongly recommends the installation of a temperature tempering valve in the DHW supply line.

**Installation Examples** *(continued)*

**Vitodens 200-W, WB2B (alternate DHW connection)**

The following piping diagram reflects an alternative connection for the DHW tank only and applies to system layouts 2, 5, 6 and 8. The boiler control pump logic function must be programmed in the Start-up/Service Instructions. .

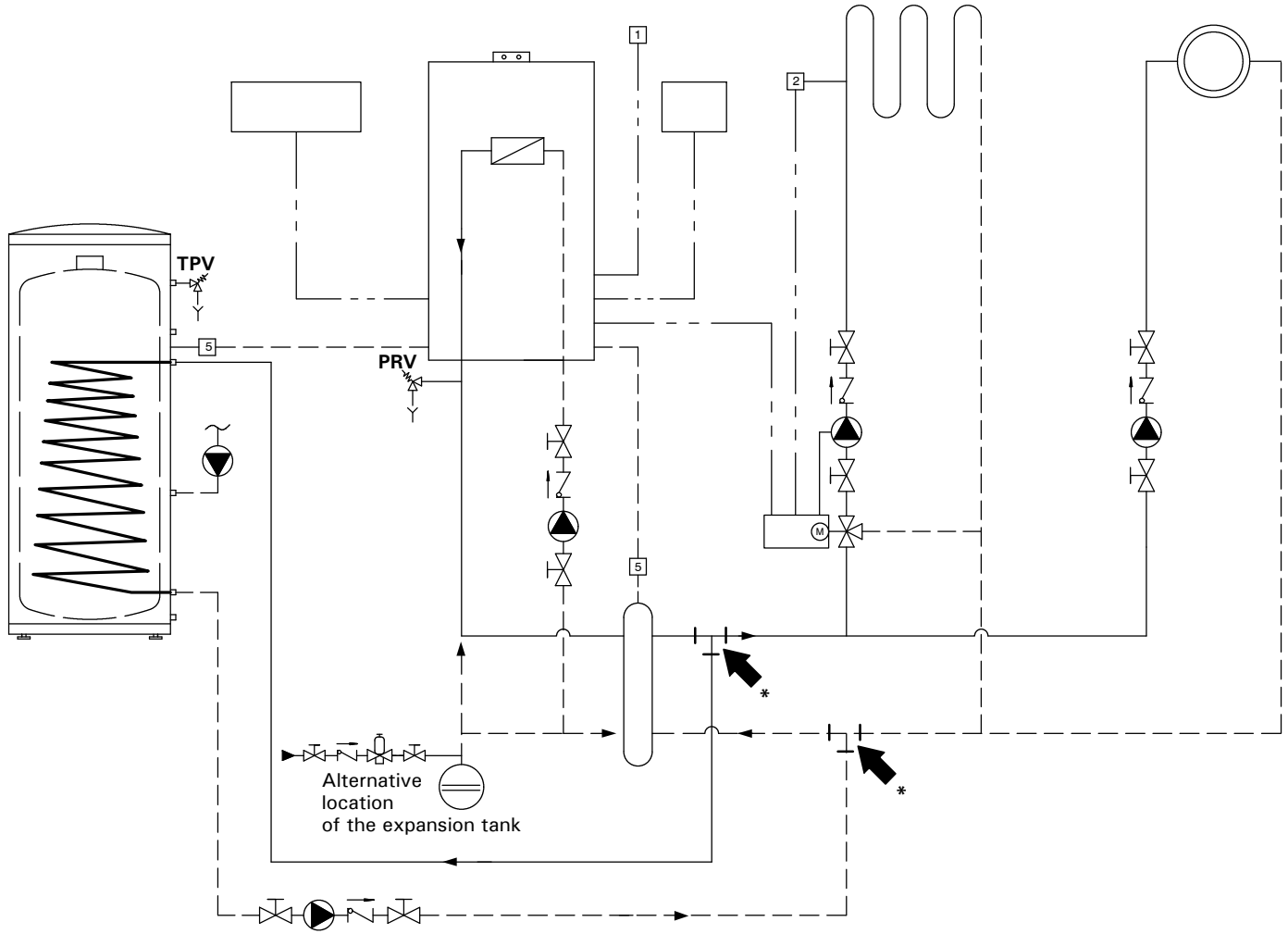

Fig. 32

**\*Note:**  
 When using a low loss header in the system, the DHW connections can be made downstream of the low loss header. See Vitodens 200-W WB2B Start-up/Service Instructions for applicable system coding information (see coding level 2):  
 00: ...  
 A2: ...  
 5b: ...

## Installation Examples *(continued)*

### Boiler in heating/cooling application

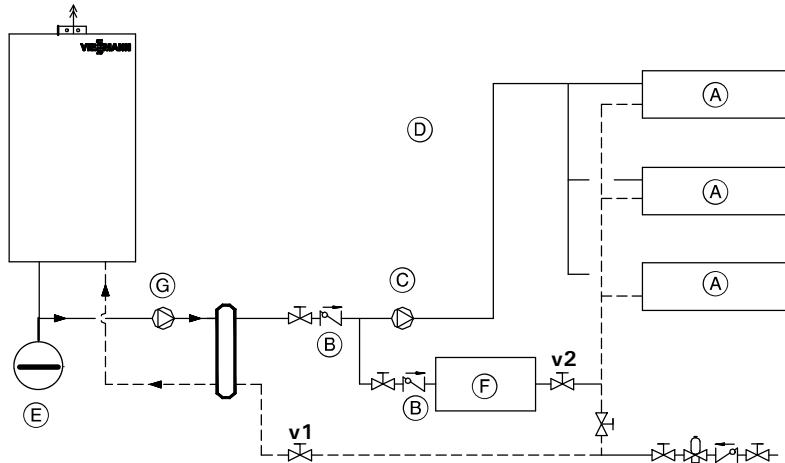

Fig. 33

#### Legend

- (A) Heating/Cooling unit
- (B) Spring-loaded flow check valve
- (C) Circulation pump
- (D) Safety header with automatic air vent and pressure relief valve
- (E) Expansion tank
- (F) Water chiller
- (G) Boiler circuit pump (field supplied)

The boiler, when used in connection with a refrigeration system, must be installed ensuring the chilled medium is piped in parallel to the boiler with appropriate valves to prevent the chilled medium from entering the boiler. See illustration on the left.

The boiler piping system of a hot water heating boiler connected to heating coils located in air handling units where they may be exposed to refrigerated air circulation must be equipped with flow control valves or other automatic means to prevent gravity circulation of the boiler water during the cooling cycle.

Check installation instructions of the chiller manufacturer carefully for additional requirements.

#### Cooling season starts:

Close valve v1 and open valve v2.

#### Heating season starts:

Close valve v2 and open valve v1.

### IMPORTANT

Viessmann strongly suggests that the valves pictured above be labelled "v1" and "v2".

### IMPORTANT

In the above system, the circulating pump must be operated from a separate on/off switch, not from the pump aquastat on the boiler control.

## Boiler Connections

### Installation Examples *(continued)*

#### Boiler with low water cut-off (remote-mounted, field supplied)

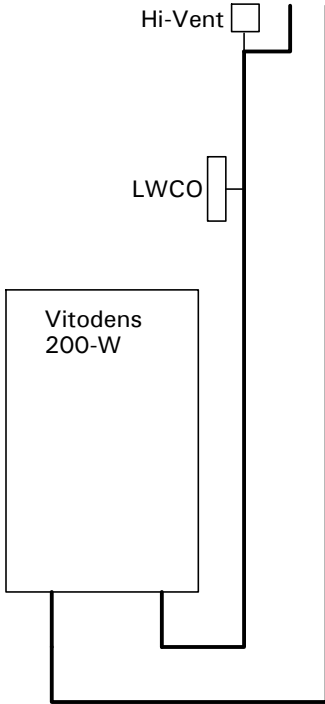

Fig. 34 Boiler below radiation

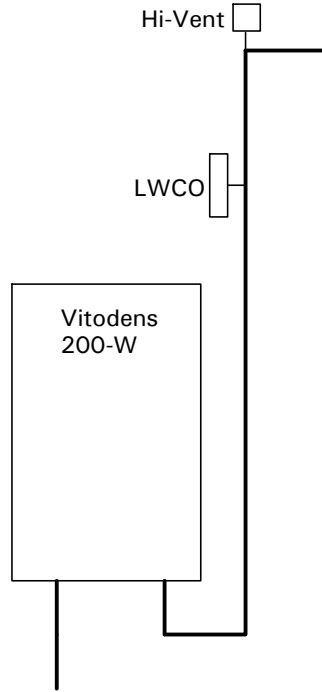

Fig. 35 Boiler above radiation

A low water cut-off may be required by local codes. If boiler is installed above radiation level, a low water cut-off device of approved type (field supplied) must be installed in all instances at the highest point of the piping system. Do **not** install an isolation valve between boiler and low water cut-off.



*Follow the installation instructions of the low water cut-off from the manufacturer.*

For low water cut-off wiring information specific to your application, refer to applicable wiring diagram on the boiler enclosure panel.

## Venting Connection

### CAUTION

Under certain climatic conditions some building materials may be affected by flue products expelled in close proximity to unprotected surfaces. Sealing or shielding of the exposed surfaces with a corrosion resistant material (e.g. aluminum sheeting) may be required to prevent staining or deterioration. The protective material should be attached and sealed (if necessary) to the building before attaching the vent termination. It is strongly recommended to install the vent termination on the leeward side of the building.



*Vitodens 200-W, WB2B  
Installation Instructions  
Venting System*



## Electrical Connections

### Overview of electrical connections and plug-in connectors

#### Power supply connection of accessories

The power supply connection of accessories can be made directly at the control. The connection is activated and deactivated with the system on/off switch. The Vitotronic 200-H, HK1M mixing valve control, the mixing valve accessory kit and the Solartrol control require a separate 120 VAC power supply from the wall receptacle.

Cabling required for:

- outdoor temperature sensor
- Vitotronic 200-H, HK1M mixing valve control
- accessory kit for heating circuit with mixing valve
- remote switching of operating mode
- remote disable
- alarm output
- wall-mount base
- circulating pump

#### Note on connection of accessories



*For details regarding other installation steps required, please reference the Installation Instructions supplied with the respective accessory part.*

*Please note that only one accessory part or switch contact can be connected to the contacts of a plug at a time.*

### Connecting the Power/Pump module



*Installation Instructions  
Power/Pump Module*

The Vitodens 200-W WB2B boiler is shipped with a Power/Pump Module, which requires a 120 VAC power supply from a wall receptacle. The module contains a 120/230 VAC step-up transformer for 230 VAC operation.

Refer to the Installation Instructions shipped with the module or those contained in this manual for wiring details (see page 53).

# Electrical Connections *(continued)*

## Connecting the Power/Pump module *(continued)*

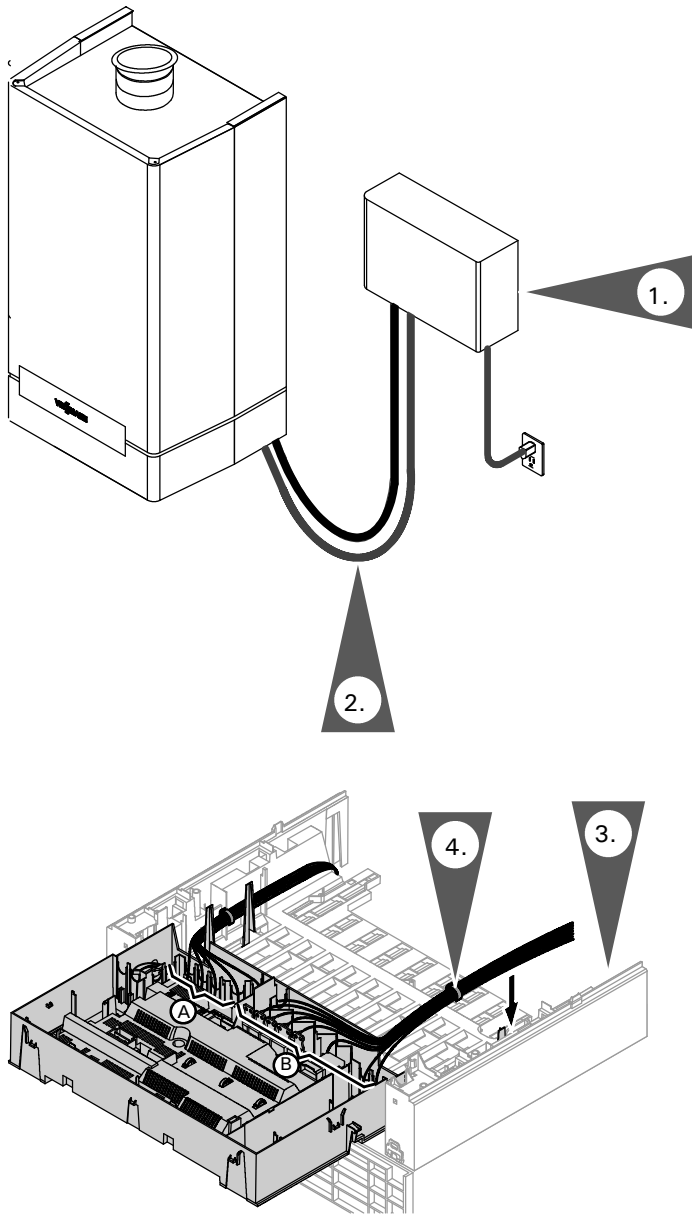

1. Remove the cover of the power pump module. Using the four screws supplied, mount the module base on the wall next to the Vitodens boiler.
2. Secure the connecting cables to the wall using the supplied conduit holding clips.

### IMPORTANT

It is essential to route cables as illustrated to ensure freedom of movement of control unit.

**CAUTION**

When running and securing connecting cables on site, ensure that the maximum permissible temperatures of the cables are not exceeded.

3. Route the cables between the control support console and control unit.
4. Secure cables behind the control unit with cable ties.

### IMPORTANT

Cables in the vicinity of the control unit must not be secured to the control unit bracket.

Fig. 36

#### Legend

- (A) Low voltage connections
- (B) 230V connections

**Electrical Connections** *(continued)*

**Power/Pump module electrical connectors**

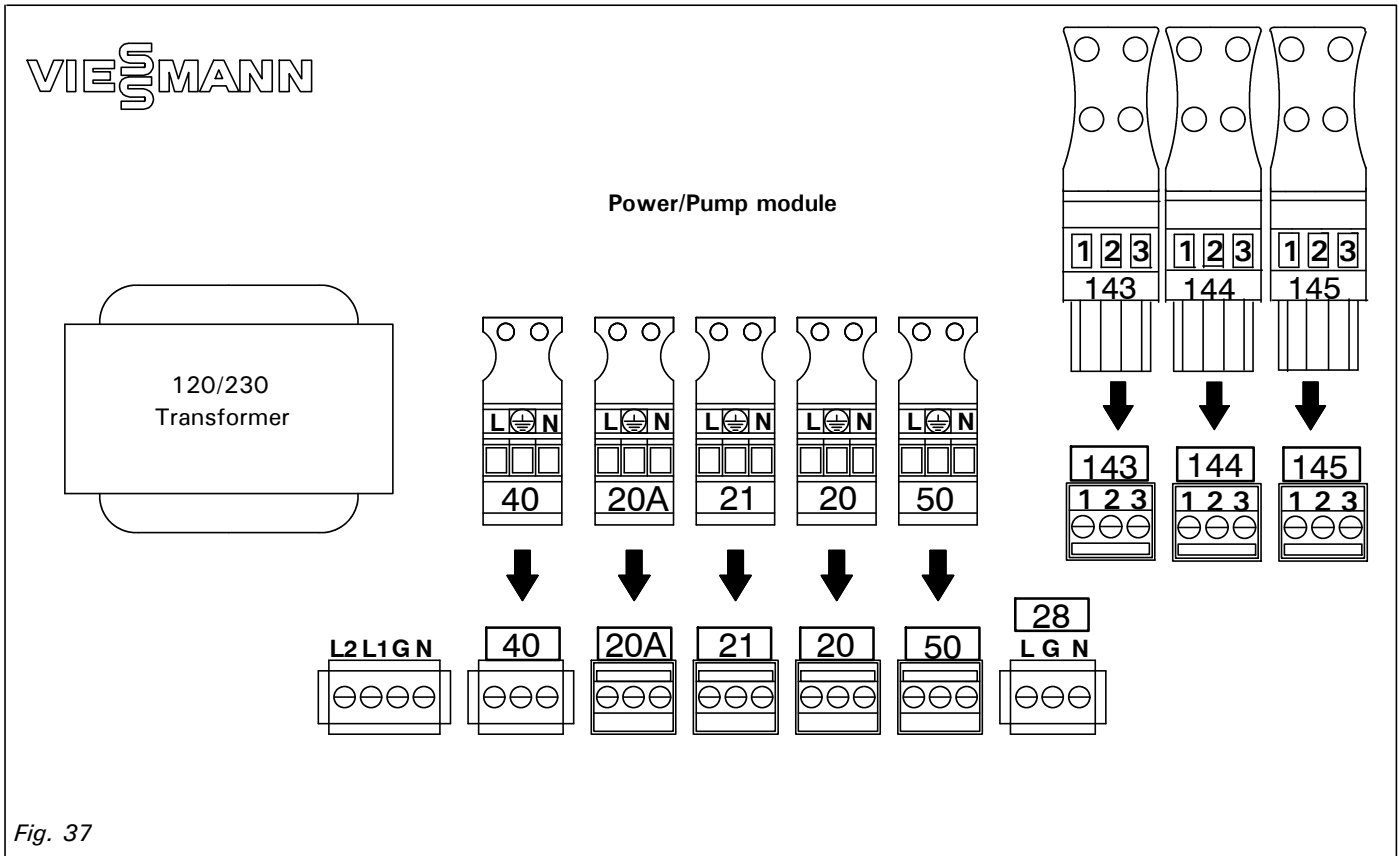

**Legend**

- 40 - Power supply
- 20A - System pump
- 21 - DHW pump
- 20 - Boiler pump
- 28 - DHW recirculation pump
- 50 - Fault alarm output
- 143 - External blocking terminals 2-3  
External demand terminals 1-2  
External heating program  
changeover terminals 1-2  
The allocation of the function  
"external heating program  
changeover" is set via coding  
address '91'
- 144 - External 0-10V signal
- 145 - KM BUS to boiler control board

5418 909 v1.6



See Vitodens 200-W WB2B  
Start-up/Service Instructions  
for applicable system coding  
information.

**Electrical Connections** *(continued)*

**Boiler control board GC 130 electrical connections**

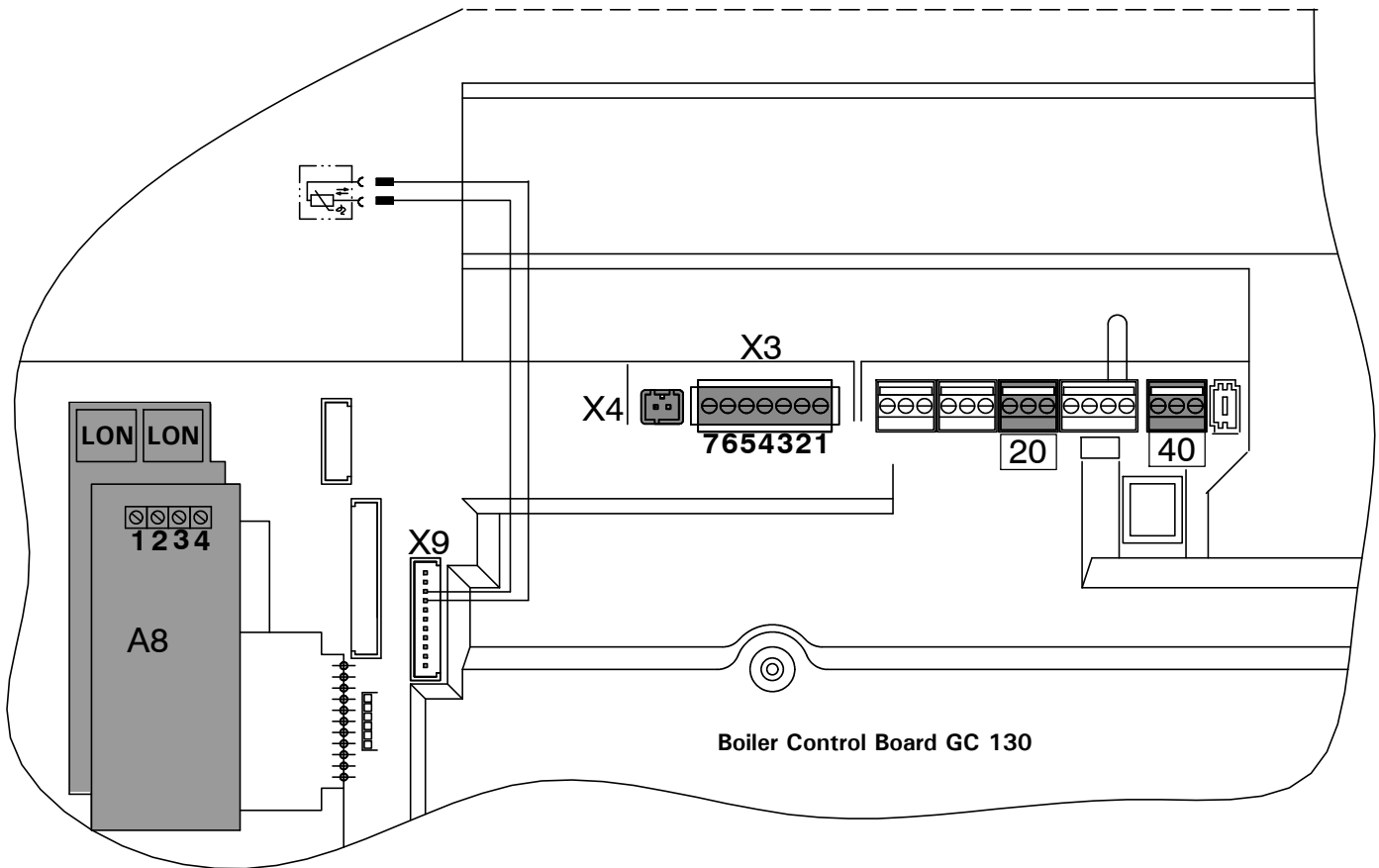

Fig. 38

**Legend**

- 40 - Power supply
- 20 - Boiler pump
- A8 - LON/cascade communication module
- x3 - Terminal block (low-loss header sensor, outdoor sensor and KM BUS connection)
- x4 - KM-BUS connection to the Power/Pump module

**Electrical Connections** *(continued)*

**Connection between the Power/Pump module and boiler**

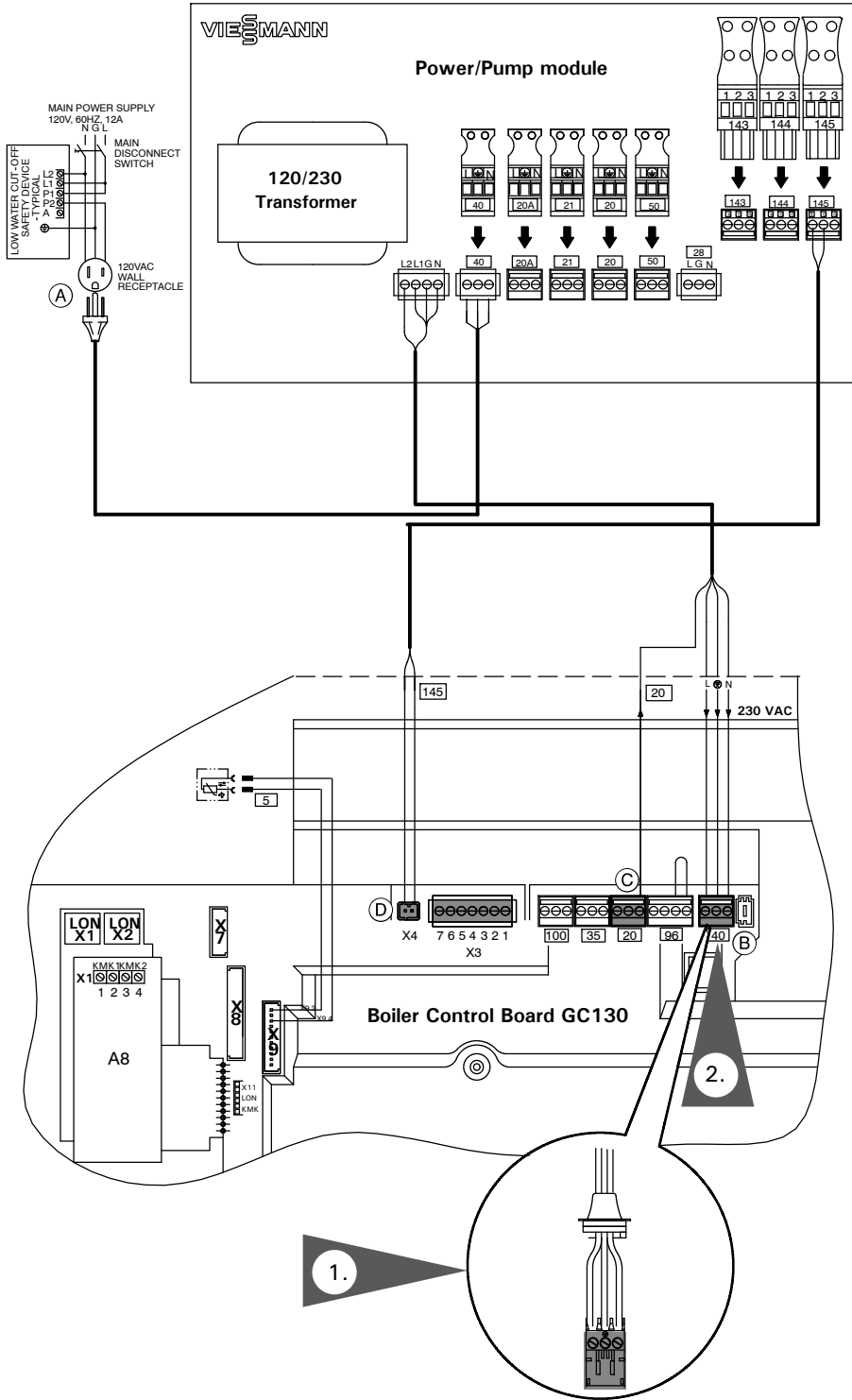

1. Remove and discard the green factory test lead plug **40** (if equipped) from the boiler control board.
2. Install the Power/Pump module plug **40** onto the boiler control board.

**Legend**

- (A) 120 VAC supply
- (B) Power supply (230 VAC)
- (C) Boiler pump
- (D) KM-BUS to Power/Pump module

**Electrical Connections** *(continued)*

**Accessories electrical connections**

See the following pages for connection to the individual accessories.

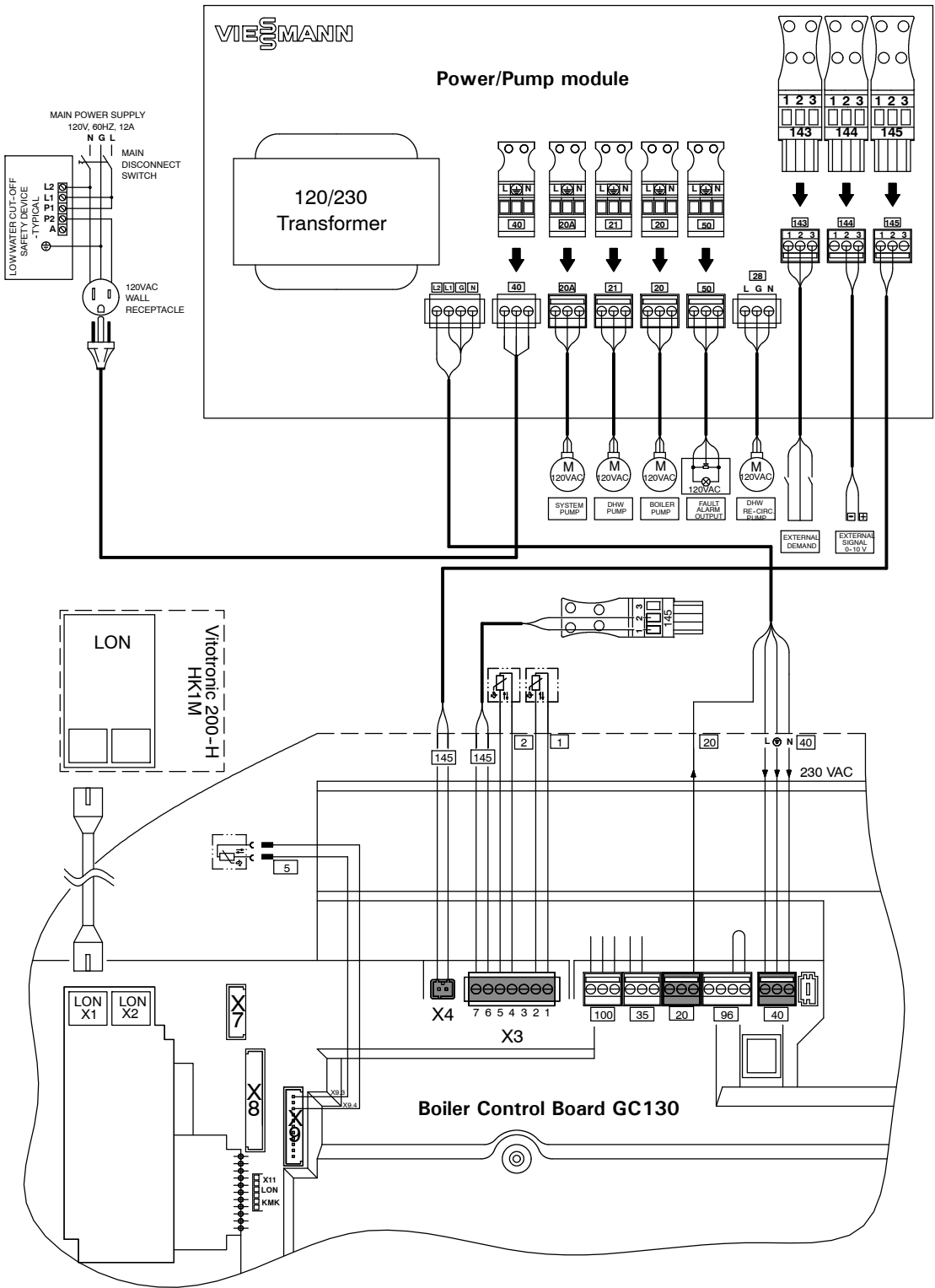

Fig. 40

## Electrical Connections *(continued)*

### Accessing the X3 plug

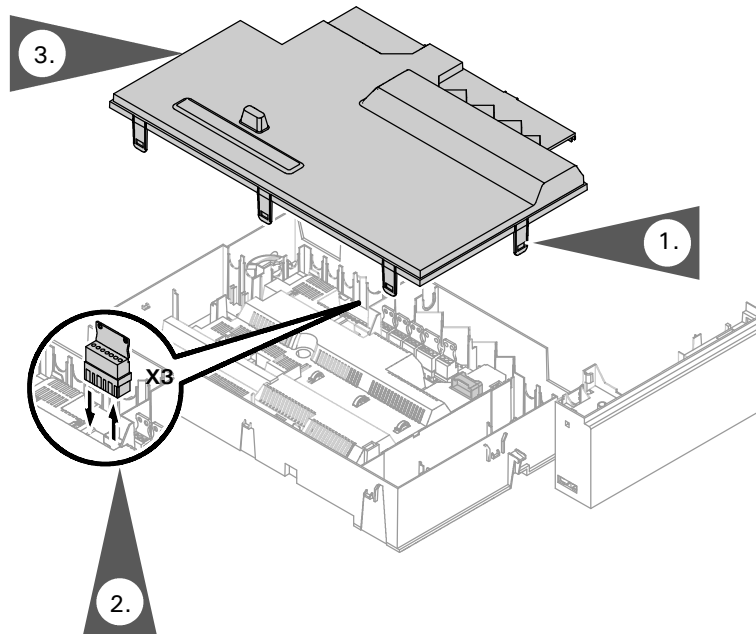

Fig. 41

1. Remove the control unit cover (see page 23).
2. Remove the X3 plug from the control board. Attach sensors and/or KM-BUS and/or accessories and reinsert the X3 plug. Refer to the following sensor information.
3. Reinstall the control cover.

### Connecting the low-loss header sensor

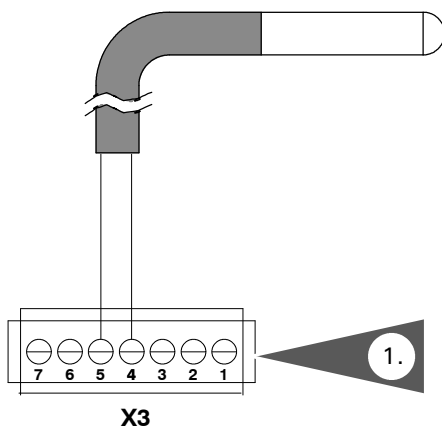

Fig. 42

1. Connect the low-loss header sensor (if used) to terminals X3.4/X3.5 on the boiler control board.

**Electrical Connections** *(continued)*

**Connecting the outdoor temperature sensor**

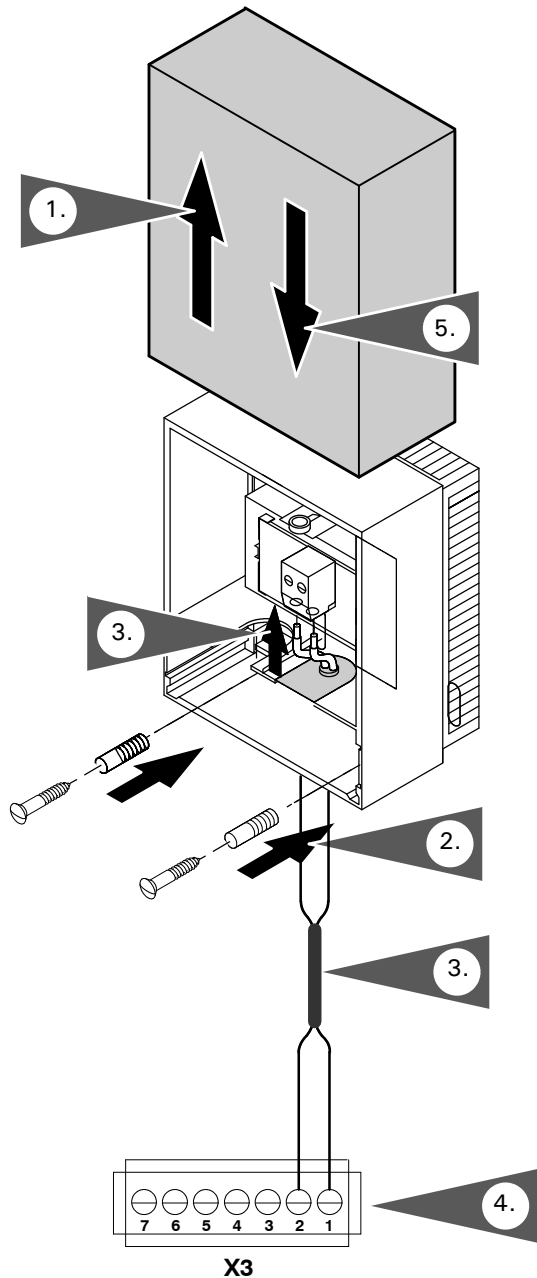

Fig. 43

1. Remove cover of outdoor temperature sensor.
2. Mount wall-mount base (cable entry must point downward).

**IMPORTANT**

The outdoor temperature sensor should be mounted 6.6 to 8.2 ft. / 2 to 2.5 m above ground level on the north or northwest wall of the building. In case of a multi-storey building, mount outdoor temperature sensor in the upper half of the second floor.

Ensure that sensor is not located above windows, doors and air vents, or immediately underneath a balcony or gutter.

The outdoor temperature sensor must not be covered by plaster. If mounting on an unplastered wall, make allowances for thickness of plaster or remove sensor before plastering wall.

3. Route cable from the boiler control board to the outdoor sensor. Connect cable to sensor terminals (wires are interchangeable).  
Cable specifications:  
2-wire cable, max. cable length 95 ft. / 35 m with a wire size of min. AWG 16 copper.

**IMPORTANT**

Cable to the outdoor sensor must not be laid near line voltage wiring (120/240 V).

4. Connect the outdoor temperature sensor to terminals X3.1/X3.2 on the boiler control board (wires are interchangeable).
5. Place cover on base and snap into place.



**Electrical Connections** *(continued)*

**External switching of heating program/External heat demand / External blocking**

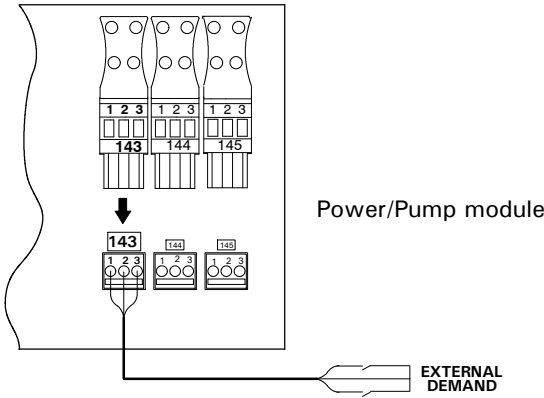

Fig. 44

- 143 - External blocking terminals 2-3
- External demand terminals 1-2
- External heating program changeover terminals 1-2
- The allocation of the function "external heating program changeover" is set via coding address '91'



See *Start-up/Service Instructions* with regard to changing the coding addresses.

**External 0-10 volt signal connection**

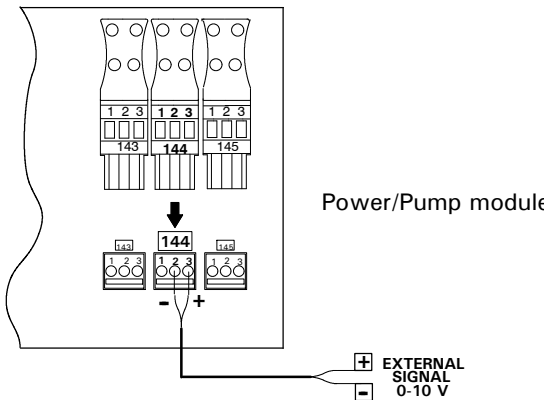

Fig. 45

1. Connect the external 0-10 V signal to plug 144 located in the Power/Pump module (shown in Fig. 45).
2. Ensure correct polarity.
3. See Fig. 46 for maximum possible boiler water temperature and required signal.

\* 7.4 VDC at 165°F / 74°C for boiler models WB2B 45, 60

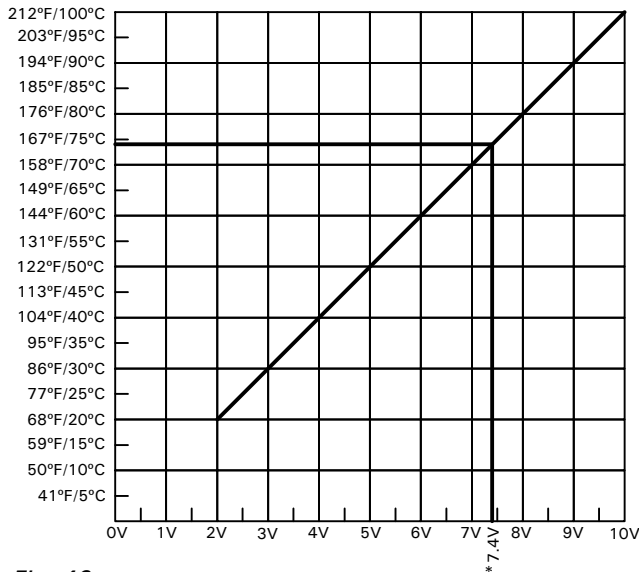
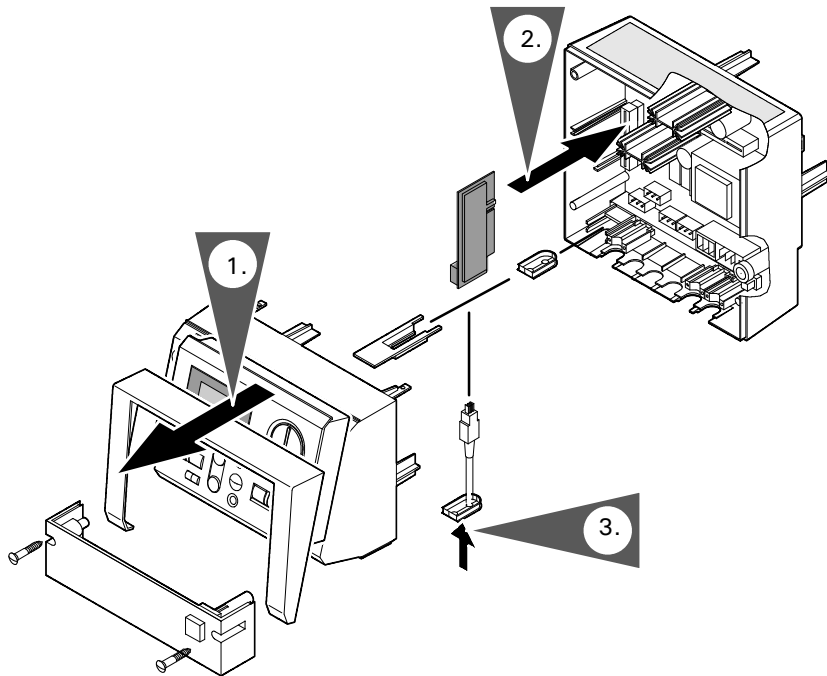

Fig. 46

# Electrical Connections *(continued)*

## Connecting the LON communication module



### Installing the LON module to the Vitotronic 200-H, HK1M mixing valve controller

1. Remove the Vitotronic 200-H, HK1M front cover.
2. Insert the LON module into the Vitotronic 200-H, HK1M control board.
3. Connect the LON connector cable to the LON module (see page 51).

 See the *Vitotronic 200-H, HK1M Installation Instructions*.

Fig. 47 *Mixing valve control*



### Installing the LON module to the boiler control board

1. Remove the control cover (see page 22).
2. Insert the LON module into the boiler control board.
3. Connect the LON connector cable to the LON module.

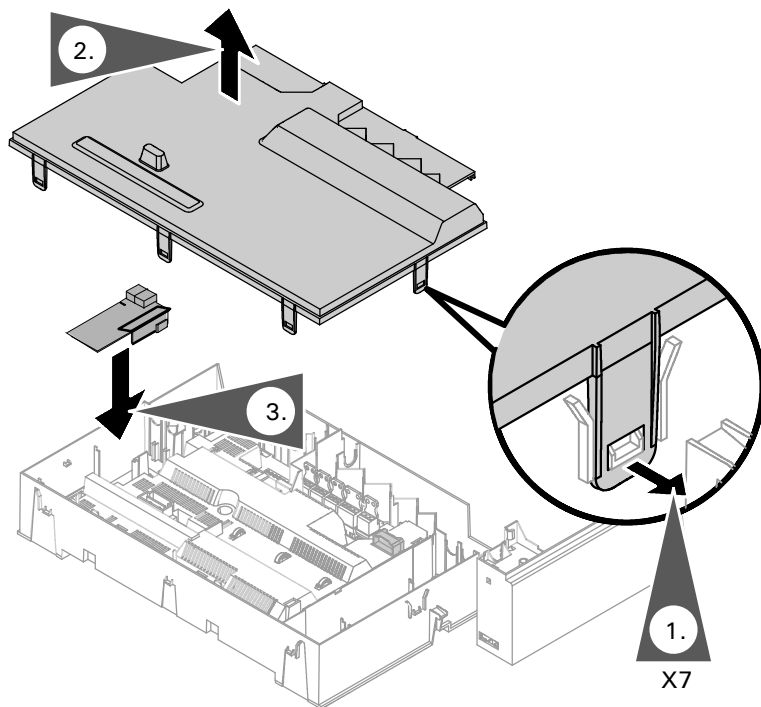
Fig. 48 *Boiler control*

**Electrical Connections** *(continued)*

**Connecting the LON communication module** *(continued)*

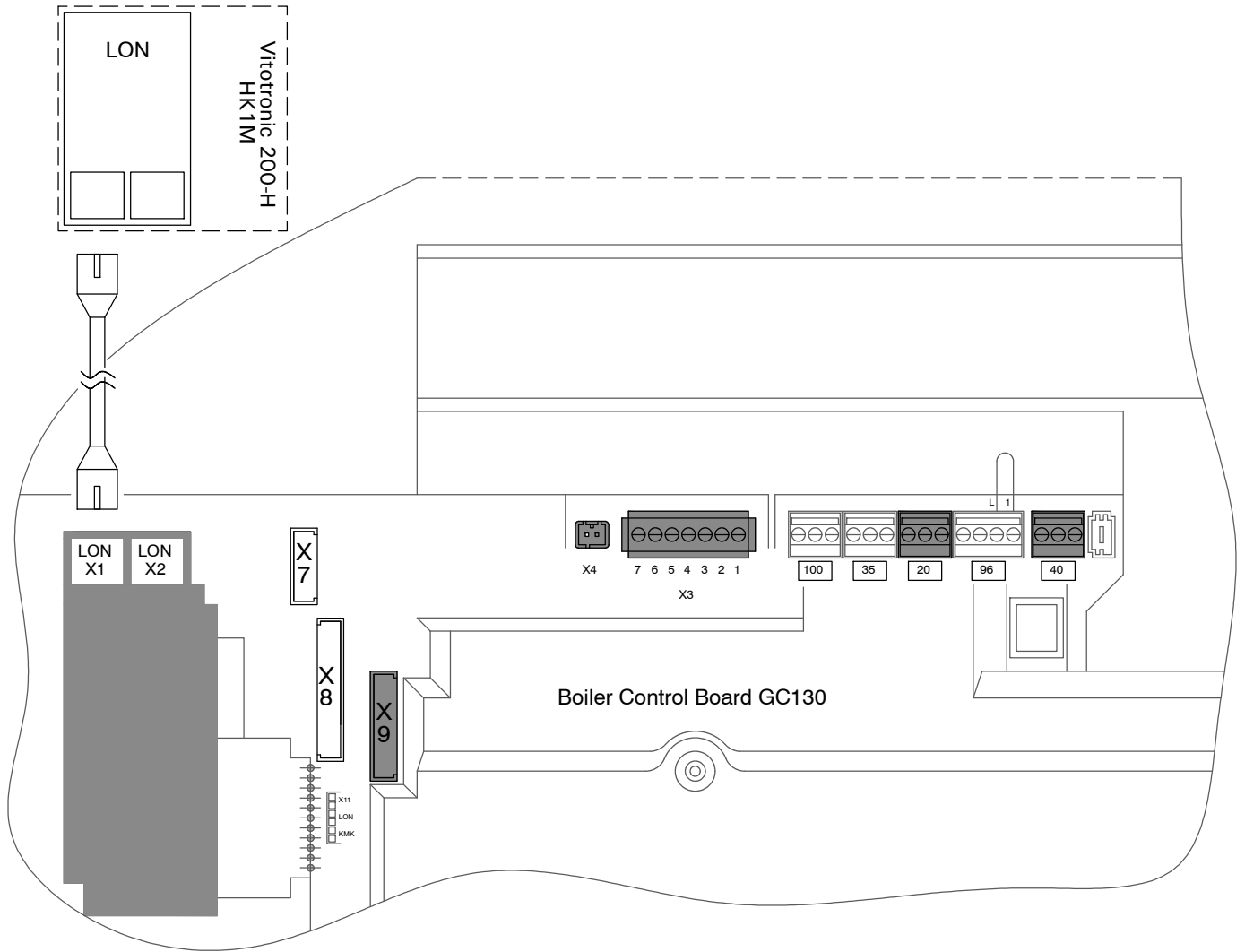

Fig. 49



See the *Vitotronic 200-H, HK1M Installation Instructions*.

**Electrical Connections** *(continued)*

Accessory kit connections for heating circuit with mixing valve part no. 7133392 (old version)

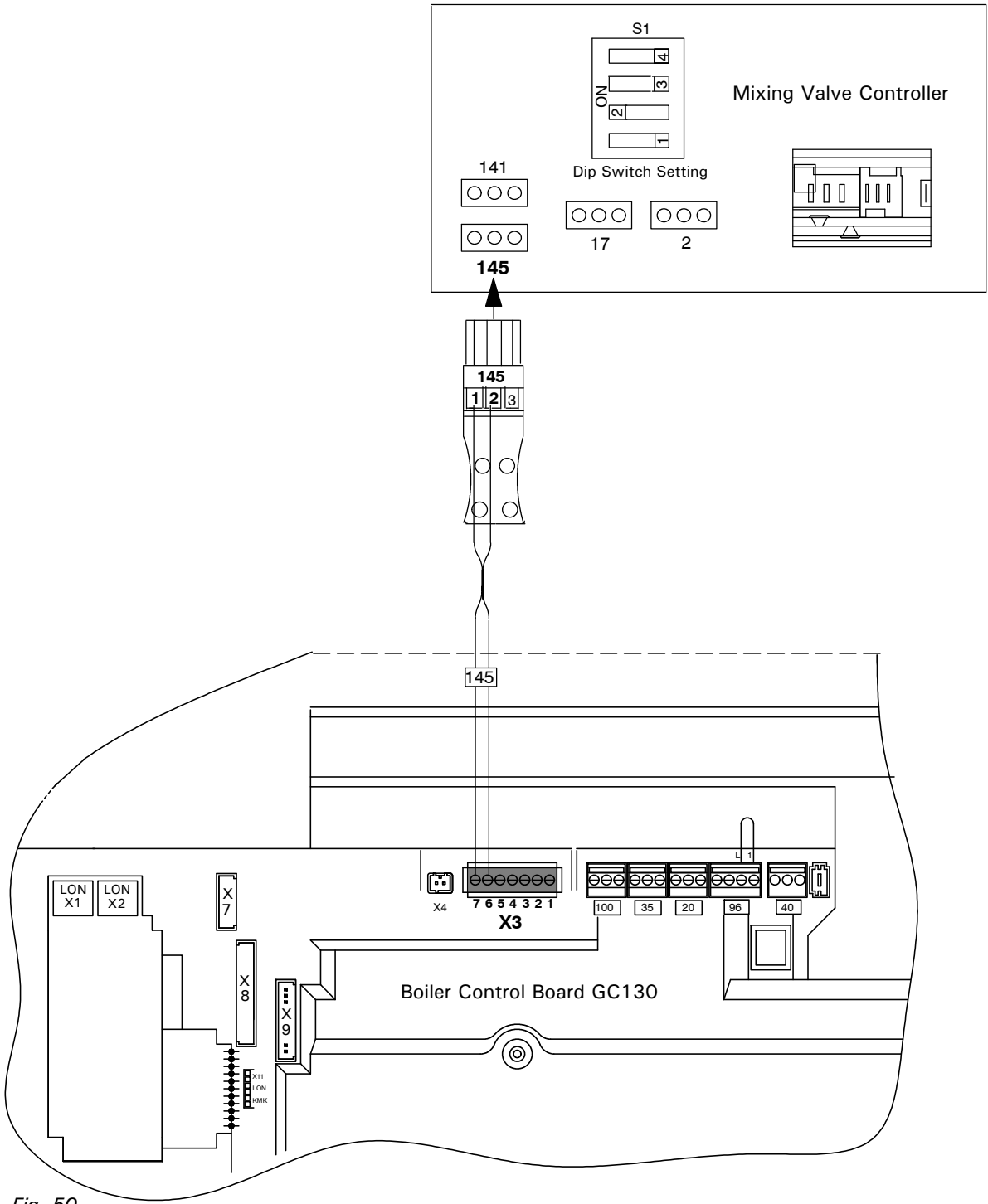

Fig. 50



See the *Mixing Valve Controller Kit for one heating circuit with mixing valve Installation Instructions.*

## Electrical Connections *(continued)*

### Accessory kit connections for heating circuit with mixing valve part no. 7837524 (new version)

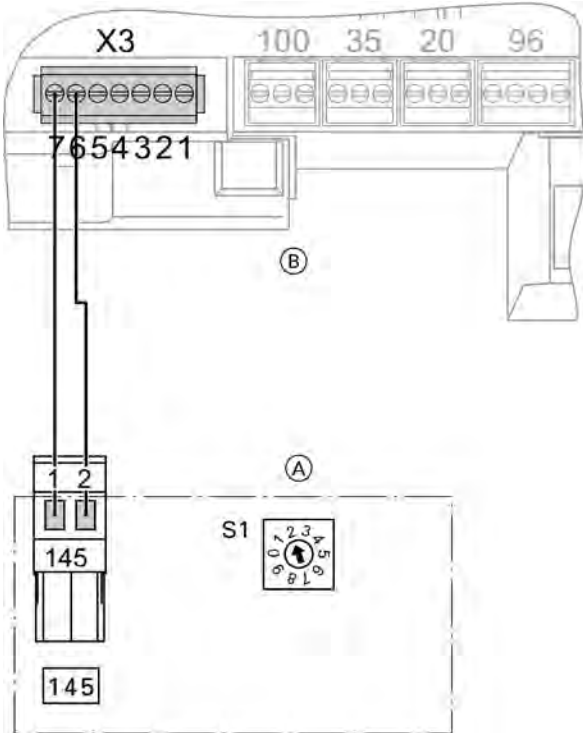

The mixing valve controller kit can only be used with wall-mounted gas-fired hot water heating boilers and a weather-responsive control; it can be used as an alternative for a Vitotronic 050/Dekamatik-HK1 control.



*For details on coding and connection to the control, please refer to the Vitodens 200 Start-up/Service Instructions*

- Ⓐ Mixing valve controller:
- 40 Power supply
  - 145 KM BUS
  - S1 Rotary selector: for position 2, (factory set)
  - 145 KM BUS to the control unit or to the KM BUS distributor (accessories)
- Ⓑ Vitotronic 200:
- "X3" KM BUS at terminals "7" and "6" (remove plug 145 )
  - or
  - 145 KM BUS to the control unit or to the KM BUS distributor (accessories)

**Electrical Connections** *(continued)*

**Wiring diagram for the boiler / Power/Pump module**

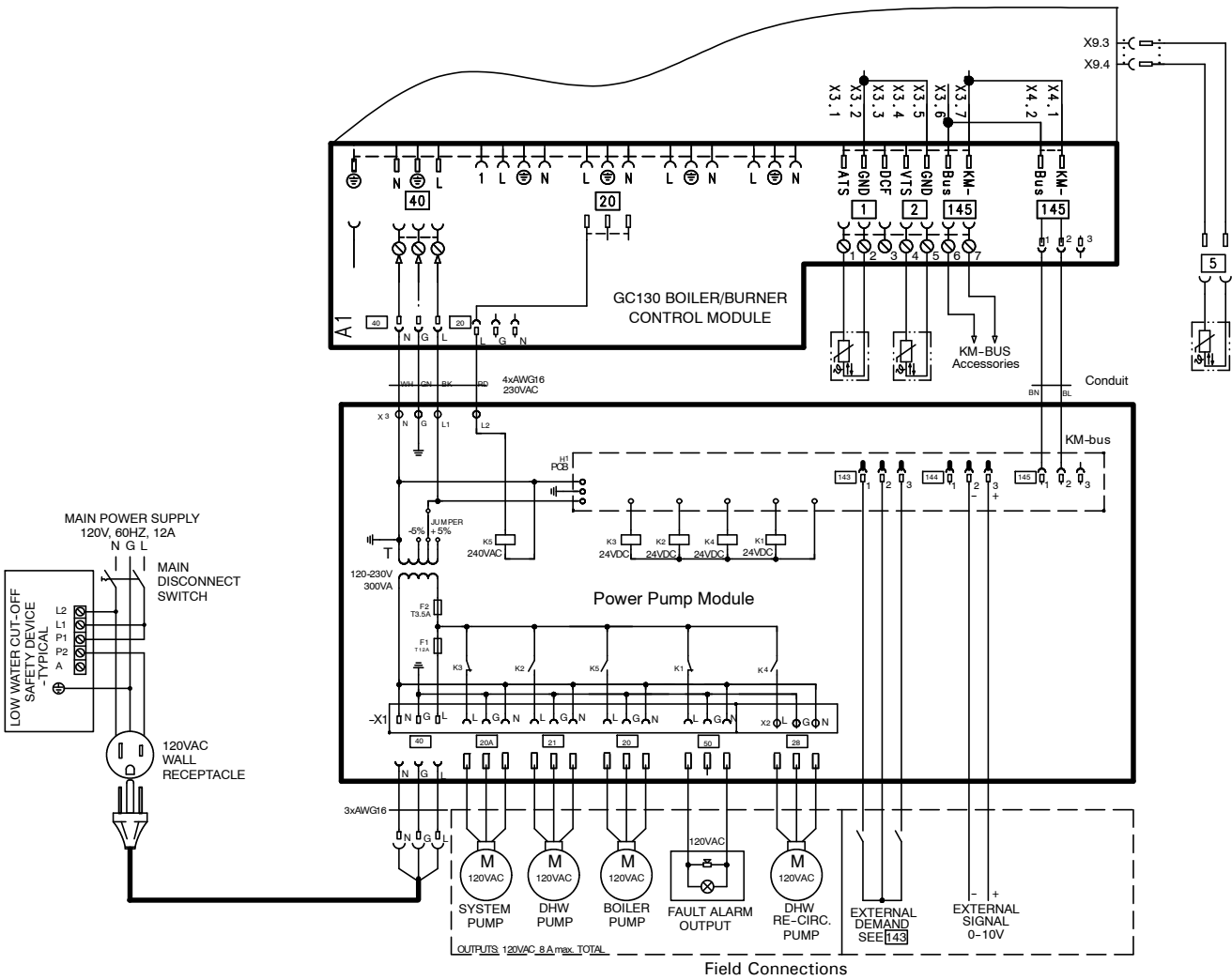

Fig. 51

**Legend**

- |  |  |
|--|--|
| <b>1</b> Outside Temperature Sensor              | <b>50</b> Fault Alarm Output   |
| <b>2</b> Flow Temperature Sensor/Low Loss Header | <b>143</b> External Blocking Terminals 2-3<br>External Demand Terminals 1-2<br>The Allocation of the Function "External Heating Program Changeover" is Set Via Coding Address '91' |
| <b>3</b> Boiler Water Temperature Sensor         | <b>144</b> External 0-10V Signal   |
| <b>5</b> DHW Temperature Sensor                  | <b>145</b> KM BUS to PPM/Accessories   |
| <b>20</b> Boiler Pump                            | <b>A1</b> Main PCB (GC130 Ignition Module)   |
| <b>20A</b> System Pump                           | <b>X...</b> Electrical Interfaces  |
| <b>21</b> DHW Pump                               |  |
| <b>28</b> DHW Re-circulation Pump                |  |
| <b>40</b> Power Supply                           |  |

BK	BLACK
WH	WHITE
G	GREEN
RD	RED
GY	GREEN/YELLOW
BN	BROWN
BL	BLUE

## Installing the Programming Unit of the Control

### Closing the control unit and inserting the programming unit

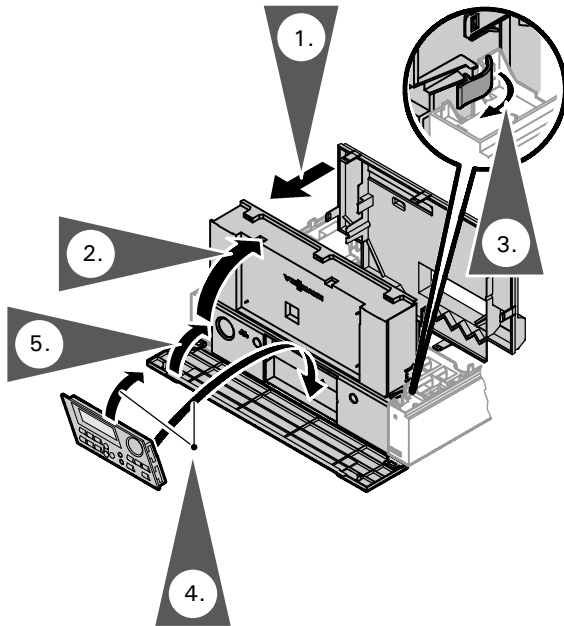
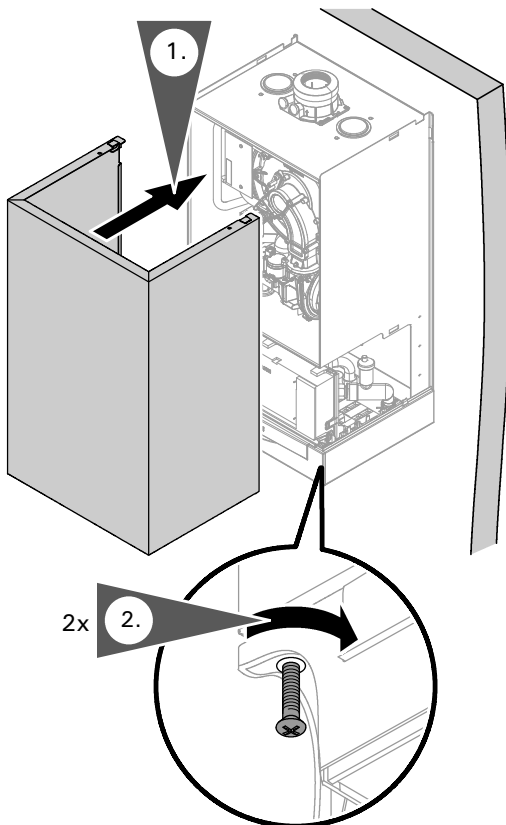

Fig. 52

1. Install the cover onto the control board.
2. Flip the control board back into position.
3. Secure the locking tabs as shown.
4. Install the Vitotronic, programming unit.
5. Close control unit cover.

### Reinstalling the front enclosure panel



1. Set front enclosure panel on the guide rails and push in place.
2. Tighten screws at the bottom.

#### IMPORTANT

Read and follow, where applicable, the safety instructions of all labels and stickers attached to boiler surfaces. Do not remove any of these instructions. Contact Viessmann if any replacement labels are required.

Fig. 53

## Additional Information

### Technical Data

Table 4

Boiler Model	Model No. WB2B		45	60
<b>Natural gas / liquid propane gas</b>				
CSA input	MBH		60-160	60-212
	kW		17-47	17-62
CSA output/DOE <sup>*1</sup>	MBH		55-146	55-194
heating capacity	kW		16-43	16-57
Net I = B = R rating <sup>*2</sup>	MBH		127	169
Heat exchanger surface area	ft. <sup>2</sup>		15.76	15.76
	m <sup>2</sup>		1.46	1.46
<b>Min. gas supply pressure</b>				
Natural gas	"w.c.		4	4
Liquid propane gas	"w.c.		10	10
<b>Max. gas supply pressure<sup>*3</sup></b>				
Natural gas	"w.c.		14	14
Liquid propane gas	"w.c.		14	14
A.F.U.E.	%		96.1	96.1
Weight	lbs		155	155
	kg		70	70
Boiler water content	USG		1.9	1.9
	ltr		7.2	7.2
Boiler max. flow rate <sup>*4</sup>	GPM		15.4	15.4
	ltr/h		3500	3500
Max. operating pressure at 210°F / 99°C	psig		60	60
	bar		4	4
<b>Boiler water temperature</b>				
– Adjustable high limit (AHL) range				
space heating	°F/		68 to 165 /	
(steady state)	°C		20 to 74	
DHW production	°F/		165 /	
	°C		74	
– Fixed high limit (FHL)	°F/°C		210/99	
<b>Boiler connections</b>				
Boiler heating supply and return	NPTM "		1 ¼	1 ¼
Pressure relief valve	NPTF "		¾	¾
Drain valve	(male thread)		¾	¾
Boiler supply/return for indirect-fired DHW storage tank NPT" (field supplied)			1 ¼	1 ¼
Gas valve connection, NPTF			1	1

<sup>\*1</sup>Output based on 140°F / 60°C, 120°F / 49°C system supply/return temperature.

<sup>\*2</sup>Net I = B = R rating based on piping and pick-up allowance of 1.15.

<sup>\*3</sup>If the gas supply pressure exceeds the maximum gas supply pressure value, a separate gas pressure regulator must be installed upstream of the heating system.

<sup>\*4</sup>See "Typical System Flow Rates" on page 28 in this manual.



## Technical Data *(continued)*

Table 4 *(continued)*

Boiler Model	Model No. WB2B		45	60
<b>Dimensions</b>				
Overall depth		inches	15	15
		mm	380	380
Overall width		inches	19	19
		mm	480	480
Overall height		inches	33½	33½
		mm	850	850
Height with flue gas elbow (accessory)		inches	47¼	47¼
		mm	1200	1200
<b>Flue gas</b> <sup>*5</sup>				
Temperature (at boiler return temperature of 86°F / 30°C)				
– at rated full load	°F/°C		95/35	104/40
– at rated partial load	°F/°C		91/33	95/35
Temperature (at boiler return temperature of 140°F / 60°C)		°F/°C	149/65	158/70
<b>Average condensate flow rate</b> <sup>*6</sup>				
with natural gas and				
– T <sub>S</sub> /T <sub>R</sub> = 104/86°F / 40/30 °C	USG/day ltr/day		3.7-5 14-19	6-7.4 23-28
<b>Condensate connection</b> <sup>*7</sup>				
	hose nozzle			
	∅ in		1	1
<b>Boiler flue gas connection</b> <sup>*8</sup>				
	∅ in/mm		3¼/80	3¼/80
<b>Combustion air supply connection (coaxial)</b> <sup>*8</sup>				
	outer ∅ in/mm		5/125	5/125

<sup>\*5</sup> Measured flue gas temperature with a combustion air temperature of 68°F / 20°C.

<sup>\*6</sup> Based on typical boiler cycles, including partial load conditions.

<sup>\*7</sup> Requires 1" / 25 mm tubing. See Vitodens 200-W Installation Instructions for details.

<sup>\*8</sup> **For side wall vent installations (coaxial system):**

Do **not** exceed max. equivalent length specified in the Venting Installation Instructions of the Vitodens 200-W, WB2B Venting System. A **maximum of five elbows** may be installed in the vent system.

Do **not** attempt to common-vent Vitodens 200-W WB2B with any other appliance.

For details refer to the Installation Instructions for the Vitodens 200-W, WB2B Venting System.

► For information regarding other Viessmann System Technology componentry, please reference documentation of respective product.

# Wiring Diagram

## Complete system wiring diagram

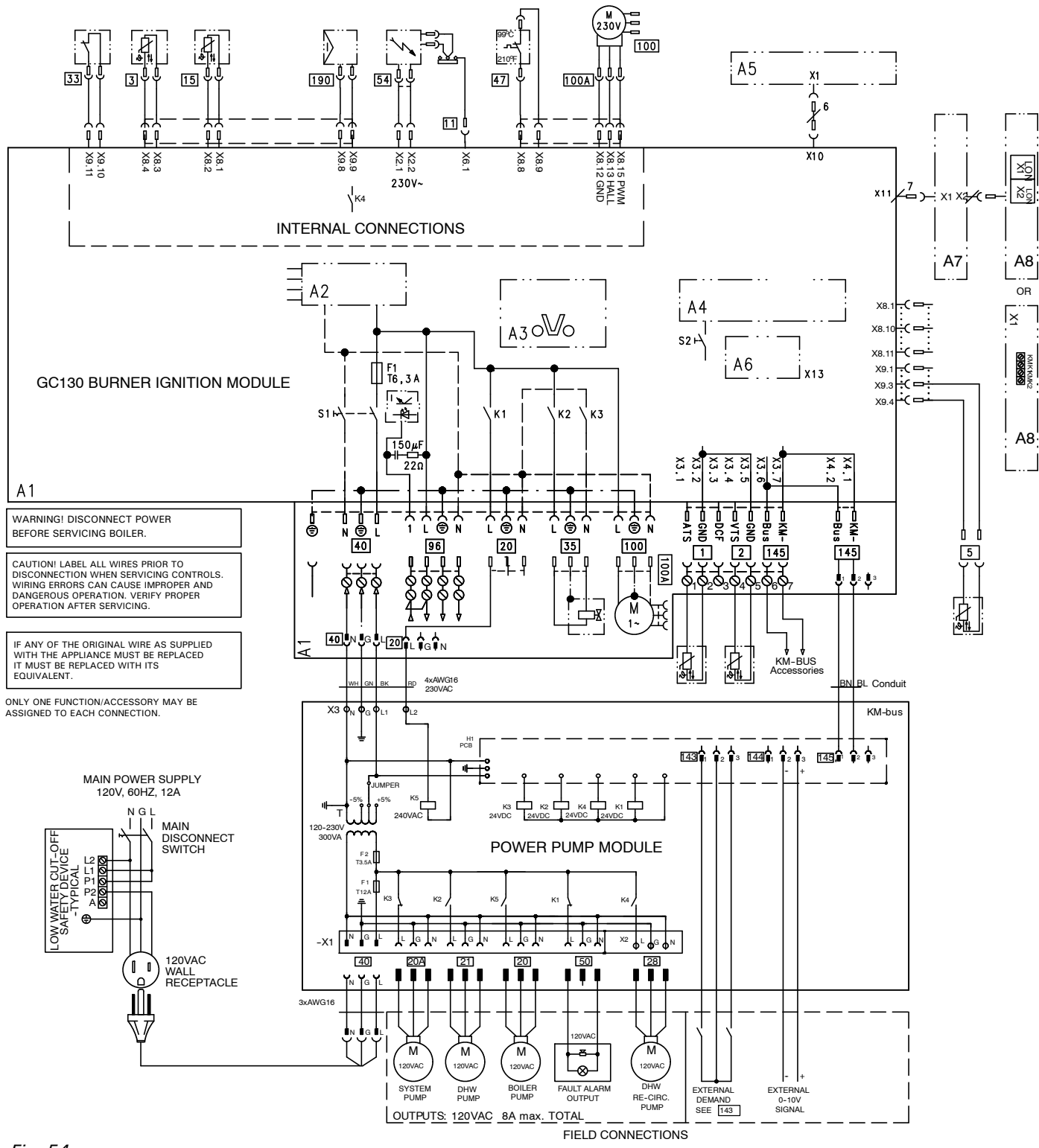

Fig. 54

See legend for this wiring diagram on next page.

## Wiring Diagram *(continued)*

### Complete system wiring diagram *(continued)*

#### Legend

- |  |  |                                     |
|--|--|-------------------------------------|
| <b>1</b> Outside Temperature Sensor              | <b>47</b> Fixed High Limit   | A1 Main PCB (GC130 Ignition Module) |
| <b>2</b> Flow Temperature Sensor/Low Loss Header | <b>50</b> Fault Alarm Output   | A2 Internal Power Supply Unit       |
| <b>3</b> Boiler Water Temperature Sensor         | <b>54</b> Ignition Transformer   | A3 Optolink                         |
| <b>5</b> DHW Temperature Sensor                  | <b>96</b> Power Supply Accessory (Not Used)  | A4 Burner Control Unit              |
| <b>11</b> Ionization Electrode                   | <b>100</b> Fan Motor   | A5 Programming Unit                 |
| <b>15</b> Flue Gas Temperature Sensor            | <b>100A</b> Fan Motor Control  | A6 Coding Card                      |
| <b>20</b> Boiler Pump                            | <b>143</b> External Blocking Terminals 2-3<br>External Demand Terminals 1-2<br>External Heating Program Changeover<br>Terminals 1-2<br>The Allocation of the Function "External<br>Heating Program Changeover" is Set<br>Via Coding Address '91' | A7 Connection Adapter               |
| <b>20A</b> System Pump                           |  | A8 LON/Cascade Communication Module |
| <b>21</b> DHW Pump                               |  | S1 ON/OFF Switch                    |
| <b>28</b> DHW Re-circulation Pump                |  | S2 Reset Button                     |
| <b>33</b> Flow Switch                            | <b>144</b> External 0-10V Signal   | X.. Electrical Interfaces           |
| <b>35</b> Gas Valve                              | <b>145</b> KM BUS to PPM/Accessories   |                                     |
| <b>40</b> Power Supply                           | <b>190</b> Gas Modulation Coil   |                                     |

BK	BLACK
WH	WHITE
G	GREEN
RD	RED
GY	GREEN/YELLOW
BN	BROWN
BL	BLUE

## Lighting and Operating Instructions

### FOR YOUR SAFETY READ BEFORE OPERATING

**W A R N I N G:** If you do not follow these instructions exactly, a fire or explosion may result causing property damage, personal injury or loss of life.

- A. This appliance does not have a pilot. It is equipped with an ignition device which automatically lights the burner. Do not try to light the burner by hand.
- B. BEFORE OPERATING smell all around the appliance area for gas. Be sure to smell next to the floor because some gas is heavier than air and will settle on the floor.
- WHAT TO DO IF YOU SMELL GAS**
- Do not try to light any appliance.
  - Do not touch any electric switch; do not use any phone in your building.
  - Immediately call your gas supplier from a neighbor's phone. Follow the gas supplier's instructions.
  - If you cannot reach your gas supplier, call the fire department.
- C. Use only your hand to push in or turn the gas control knob. Never use tools. If the knob will not push in or turn by hand, don't try to repair it, call a qualified service technician. Force or attempted repair may result in a fire or explosion.
- D. Do not use this appliance if any part has been under water. Immediately call a qualified service technician to inspect the appliance and to replace any part of the control system and any gas control which has been under water.

### OPERATING INSTRUCTIONS

1. STOP! Read the safety information above on this label.
2. Set thermostat or other operating control to lowest setting.
3. Turn off all electric power to the appliance.
4. This device is equipped with an ignition device which automatically lights the burner. Do not try to light the burner by hand.
5. Close main gas shut-off valve.
6. Wait five (5) minutes to clear out any gas. Then smell for gas, including near the floor. If you smell gas, STOP! Follow "B" in the safety information above on this label. If you don't smell gas, go to the next step.
7. Open main gas shutoff valve.
8. Turn on all electric power to the appliance.
9. Set thermostat or other operating control to desired setting.
10. If the appliance will not operate, follow the instructions "To Turn Off Gas To Appliance" and call your service technician or gas supplier.

Manual gas shutoff

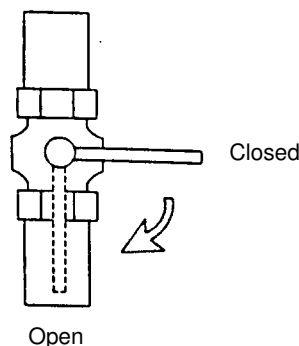

### TO TURN OFF GAS TO BOILER

1. Set thermostat or other operating control to lowest setting.
2. Turn off all electric power to the appliance if service is to be performed.
3. Close main gas shut-off valve.

**Ladder Diagram**

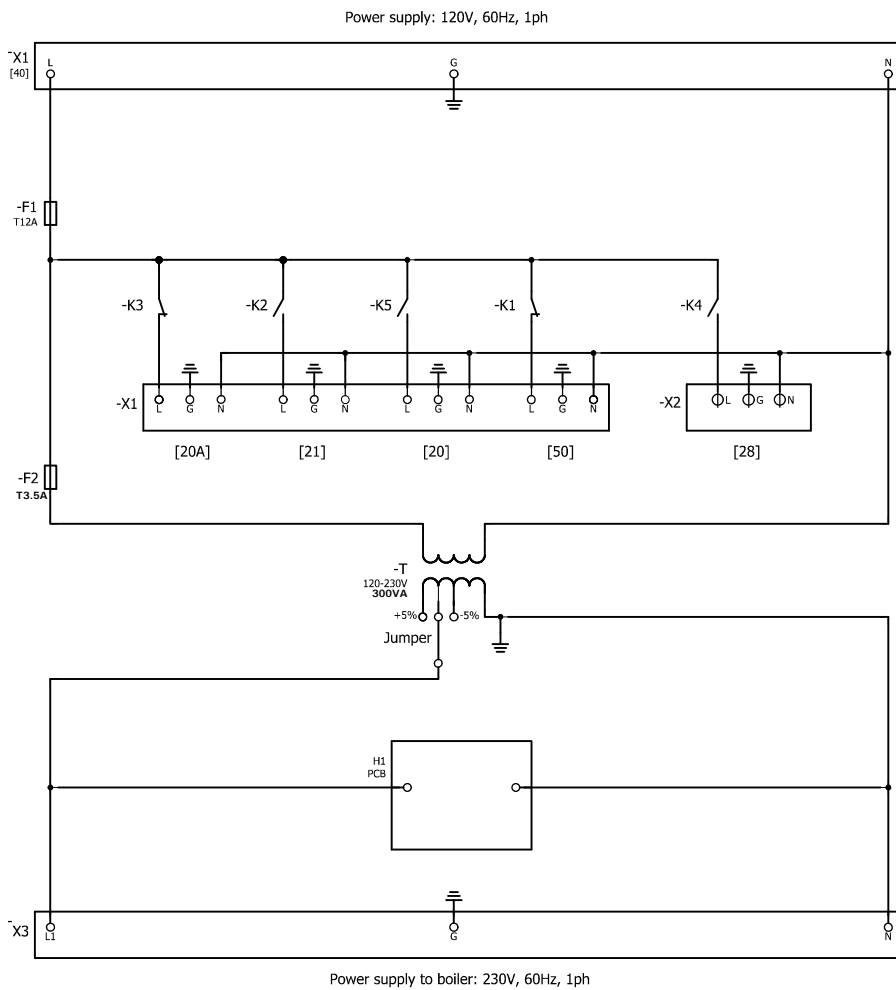

**Legend**

- X1 [40] power supply 120 VAC
- X1 [20A] pump, HTG system w/o mixing valve, 120 VAC
- X1 [21] pump DHW tank 120 VAC
- X1 [20] pump boiler 120 VAC
- X1 [50] fault alarm 120 VAC
- X2 [28] pump, DHW recirculation, 120 VAC

**IMPORTANT**

**Total max. output current 8A**

- X3 boiler power supply 230 VAC
- K1, -K2, -K3, -K4, -K5 operating contacts
- F1, -F2 fuses (slow blow)
- T transformer
- H1 communication board

Fig. 55







Viessmann Manufacturing Company (U.S.) Inc.  
45 Access Road  
Warwick, Rhode Island • 02886 • USA  
Tel. (401) 732-0667 • Fax (401) 732-0590  
www.viessmann-us.com • info@viessmann-us.com

Viessmann Manufacturing Company Inc.  
750 McMurray Road  
Waterloo, Ontario • N2V 2G5 • Canada  
Tel. (519) 885-6300 • Fax (519) 885-0887  
www.viessmann.ca • info@viessmann.ca

